

Rev	AWO #	Description	Date	Appr
-		RELEASED	11/12/10	

APPROVED: \_\_\_\_\_  
 DATE: \_\_\_\_\_ TITLE: \_\_\_\_\_

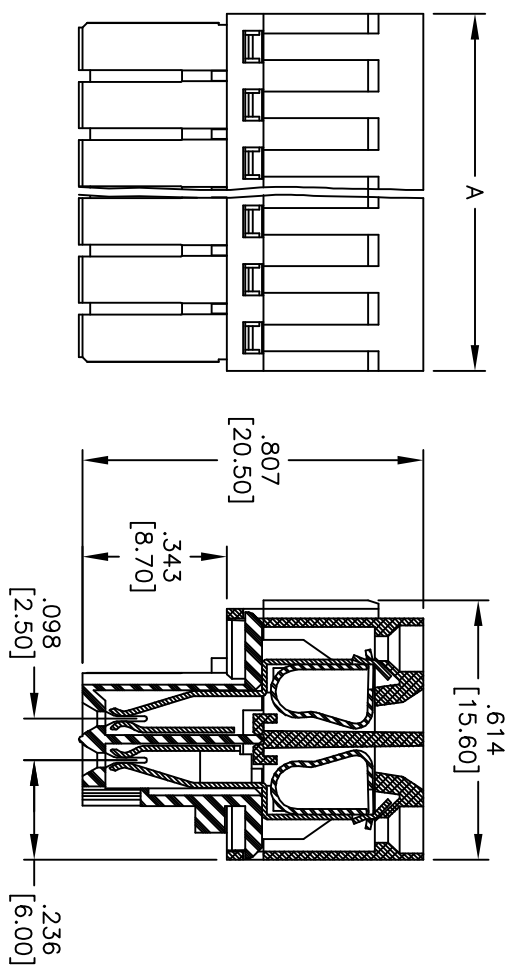
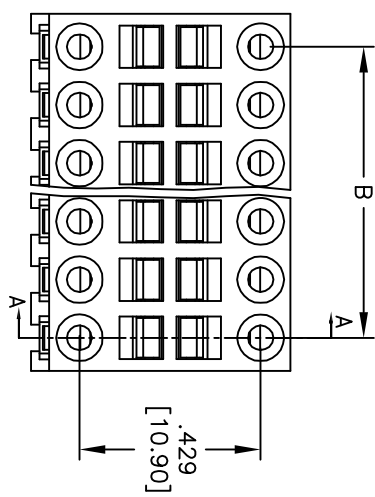

SECTION A-A

Poles: 4, 6, 8 thru 48  
 A = .138 [3.50] X No. of Spaces + .157 [4.00]  
 B = .138 [3.50] X No. of Spaces

**ADAM TECH**  
 909 Rahway Avenue, Union, NJ 07083  
 Phone: 908-687-5000 Fax: 908-687-5710

TITLE  
**EURO BLOCK, .138 [3.50] PITCH**  
**4 THRU 48 POLES**

**SPECIFICATIONS:**  
 Material: Insulator: Thermoplastic, rated UL 94V-0  
 Insulator color: Orange  
 Spring clamp: Stainless steel  
 Contact: Phosphor Bronze, Tin plated.  
 Electrical:  
 Operation voltage: 150 VAC  
 Current rating: 7 Amps  
 Solid wire: 18-28 AWG  
 Stranded wire: 18-28 AWG  
 Wire strip length: 7-8mm  
 Mechanical:  
 Withstanding Voltage: 1.6KV  
 Environmental:  
 Operating temperature: -40°C to +115°C  
 Lead free, RoHS compliant.  
 Recommended soldering temp: 235°C for 5 sec.



UNLESS OTHERWISE SPECIFIED ALL DIMENSIONS ARE MM [INCHES]	
TOLERANCES: EXCEPT AS NOTED	
INCHES	HOLES
.X ± .10	ØXX ± .10
.XX ± .020	ØXXX ± .015
.XXX ± .015	ØXXXX ± .010
APPROVALS	DATE
DRAWN AY	11/12/10
CHECKED AW	11/12/10
APPROVED	

SIZE	PART NO.	REV.
X	EB121-XXA	-
REF: S00007T	SCALE: NTS	SHEET 1 OF 1