

Y transition with self-locking feature for ease of assembly and repair for multi-legged conduit assemblies. Use H code conduit fittings to interface.

How To Order

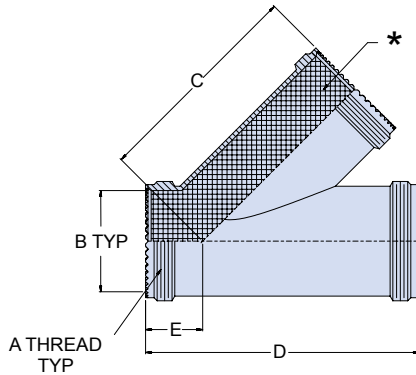
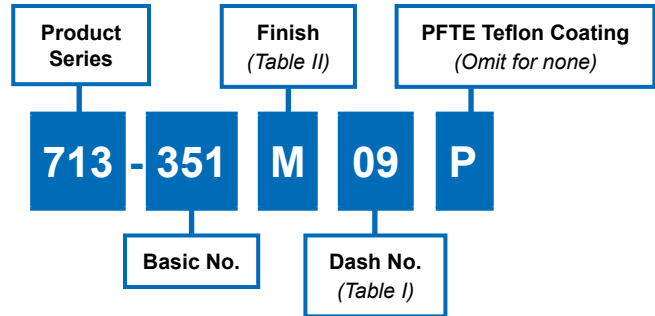

Sym	Material	Finish Description
M	Aluminum	Electroless Nickel
MT		Nickel-PTFE
NF		Cad/Olive Drab over Electroless Nickel
ZN		Zinc Nickel/Olive Drab over Electroless Nickel
ZNU		Zinc Nickel/Black over Electroless Nickel
Z1	Stainless Steel	Passivate

Dash No	Conduit Size (Ref)	A Thread Iso Metric	B Dia	C Max	D Max	E Max
09	06,09	M12 x 1.0-6g	.281 (7.1)	1.38 (35.1)	1.87 (47.5)	.52 (13.2)
11	10,12	M15 x 1.0-6g	.397 (10.1)	1.60 (40.6)	2.11 (53.6)	.54 (13.7)
13	14,16	M18 x 1.0-6g	.511 (13.0)	1.75 (44.5)	2.28 (57.9)	.57 (14.5)
15	20	M22 x 1.0-6g	.636 (16.2)	1.90 (48.3)	2.47 (62.7)	.60 (15.2)
17	24	M25 x 1.0-6g	.761 (19.3)	2.09 (53.1)	2.69 (68.3)	.63 (16.0)
19	28	M28 x 1.0-6g	.875 (22.2)	2.22 (56.4)	2.84 (72.1)	.65 (16.5)
21	32	M31 x 1.0-6g	1.000 (25.4)	2.36 (59.9)	3.00 (76.2)	.68 (17.3)
23	36	M34 x 1.0-6g	1.125 (28.6)	2.50 (63.5)	3.17 (80.5)	.70 (17.8)
25	40	M37 x 1.0-6g	1.250 (31.8)	2.66 (67.6)	3.35 (85.1)	.73 (18.5)
33	48	M45 x 1.5-6g	1.530 (38.9)	3.10 (78.7)	3.87 (98.3)	.80 (20.3)
37	56	M50 x 1.5-6g	1.750 (44.5)	3.39 (86.1)	4.21 (106.9)	.84 (21.3)

Material and Finish

See Table II.

*Internal Surface coated with Teflon as shown, see P/N development.