

RL-7900-2

COMMON MODE CHOKE COILS FOR SIGNAL LINES

DESCRIPTION

- Common Mode Choke

ENVIRONMENTAL DATA

- Storage temperature range: -55°C to +130°C
- Operating temperature range: -40°C to +130°C

PACKAGING INFORMATION

- Packaging information: pg. 506

FEATURES & APPLICATIONS

- Small size of 3216 Type (EIA 1206)
- Great performance in suppressing noise over high frequency
- Ferrite or ceramic body with wire-wound type of construction
- Suitable for radiation noise suppression for any electronic devices
- Also used to counter common mode noise interference within high speed signal lines
- Typical applications include: USB 2.0 line, peripheral devices, and IEEE 1394 line for personal computers

Verify operation with sample in actual circuit. Order samples at www.rencousa.com.

MECHANICAL DIMENSIONS

U.S. Standard (mm)

PART NUMBER	A (MAX.)	B (MAX.)	C	D (MAX.)	E	F
RL-7900-2	0.130 (3.40)	0.090 (2.20)	0.010 (0.17)	0.070 (1.80)	0.020 (0.60)	0.020 (0.60)

PART NUMBER	PART WEIGHT	G (REF.)	H (REF.)	I (REF.)	J (REF.)
RL-7900-2	0.12g (0.004oz)	0.040 (1.05)	0.020 (0.60)	0.074 (1.90)	0.020 (0.60)

FRONT VIEW

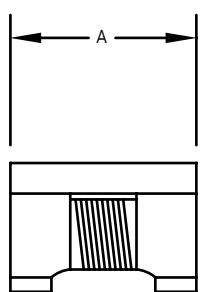

SIDE VIEW

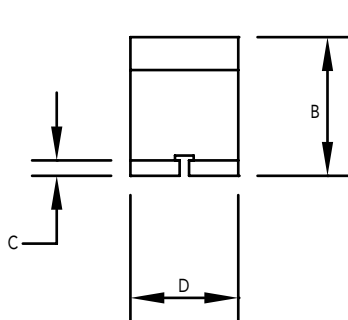

BOTTOM VIEW

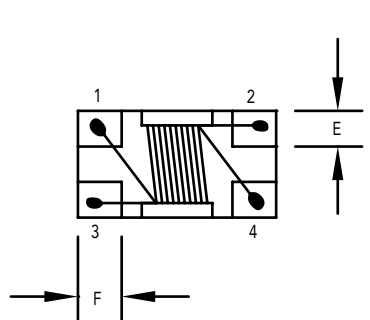

RECOMMENDED LAND PATTERN

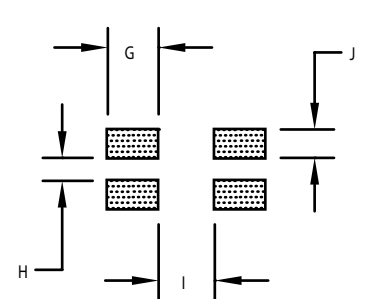

SCHEMATIC

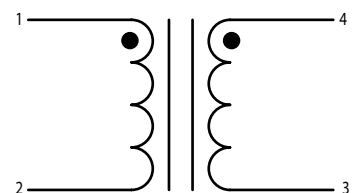

RL-7900-2

Renco Part No. RL-7900-2	Common Mode Impedance (Ohms)	Test Frequency (MHz)	DCR Max. (Ohms)	Rated Current (mA)	Rated Voltage (Vdc)	Withstand Voltage (Vdc)	IR (Ohms) Min.
RL-7900-2-30	30 ± 25%	100	0.20	400	50	125	10M
RL-7900-2-67	67 ± 25%	100	0.30	400	50	125	10M
RL-7900-2-80	80 ± 25%	100	0.30	400	50	125	10M
RL-7900-2-90	90 ± 25%	100	0.30	400	50	125	10M
RL-7900-2-120	120 ± 25%	100	0.30	400	50	125	10M
RL-7900-2-160	160 ± 25%	100	0.35	350	50	125	10M
RL-7900-2-180	180 ± 25%	100	0.35	350	50	125	10M
RL-7900-2-220	220 ± 25%	100	0.45	300	50	125	10M
RL-7900-2-260	260 ± 25%	100	0.45	300	50	125	10M
RL-7900-2-280	280 ± 25%	100	0.45	300	50	125	10M
RL-7900-2-300	300 ± 25%	100	0.50	300	50	125	10M
RL-7900-2-360	360 ± 25%	100	0.60	300	50	125	10M
RL-7900-2-430	430 ± 25%	100	0.60	300	50	125	10M
RL-7900-2-470	470 ± 25%	100	0.70	300	50	125	10M
RL-7900-2-550	550 ± 25%	100	0.75	300	50	125	10M
RL-7900-2-600	600 ± 25%	100	0.80	300	50	125	10M
RL-7900-2-2200	2200 ± 25%	100	1.20	200	50	125	10M



RENCO ELECTRONICS INC.

595 International Place, Rockledge, FL 32955-4200 USA • www.rencousa.com • ISO 9001 Certified
Toll Free Engineering Hot Line: 800.645.5828 • P: 321.637.1000 • F: 321.637.1600



RL-7900-2

RL-7900-2-30

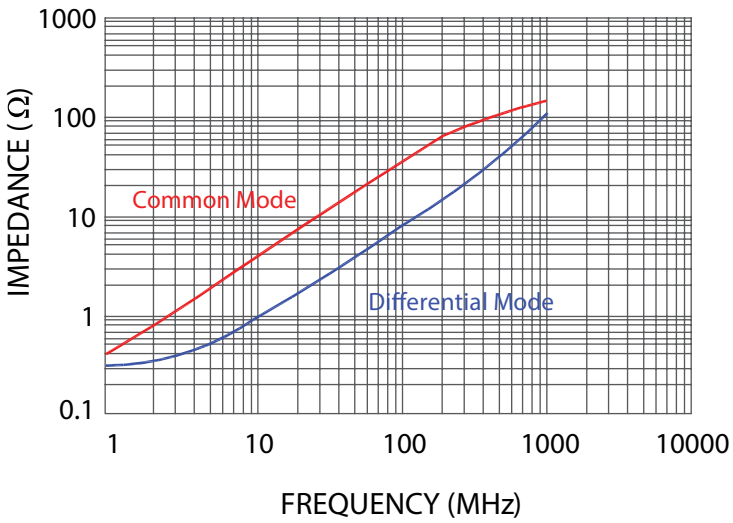

RL-7900-2-67

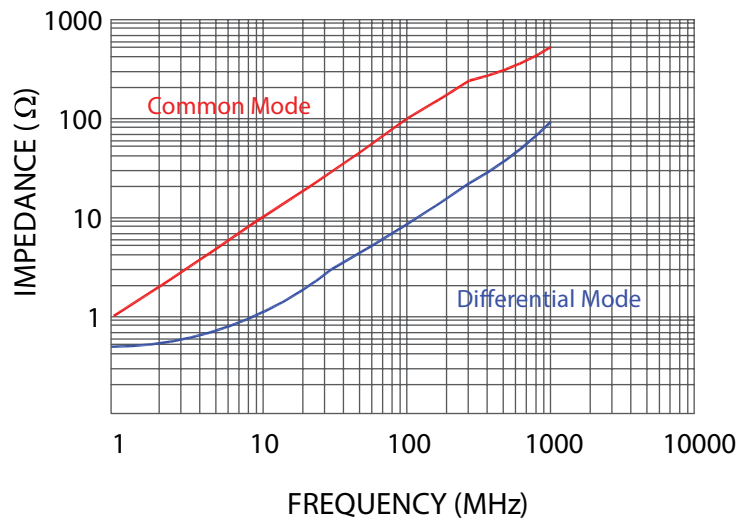

RL-7900-2-80

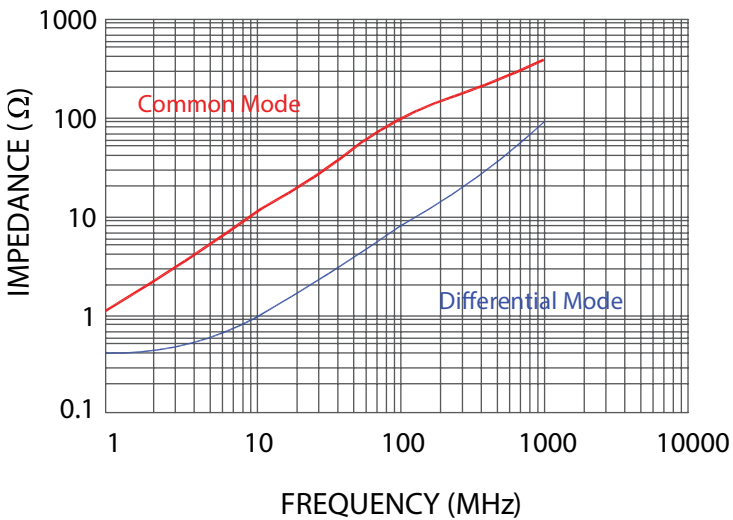

RL-7900-2-90

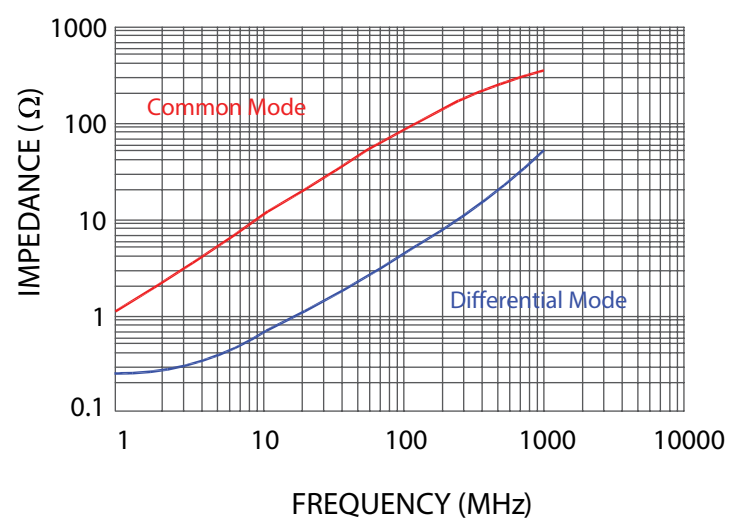

RL-7900-2

RL-7900-2-120

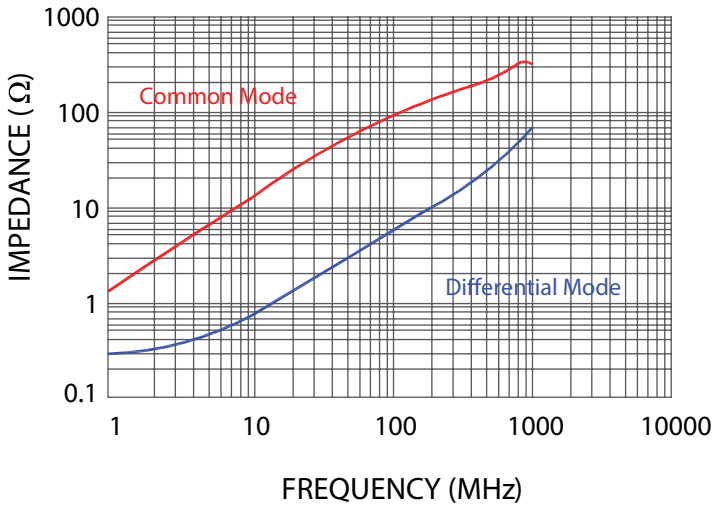

RL-7900-2-160

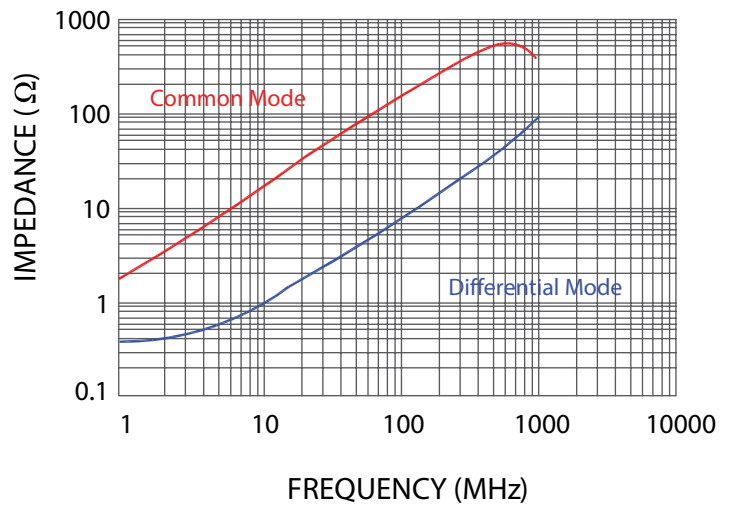

RL-7900-2-180

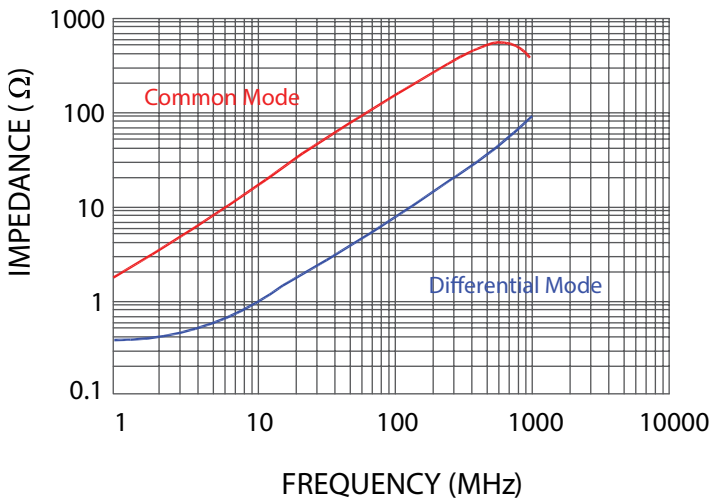

RL-7900-2-220

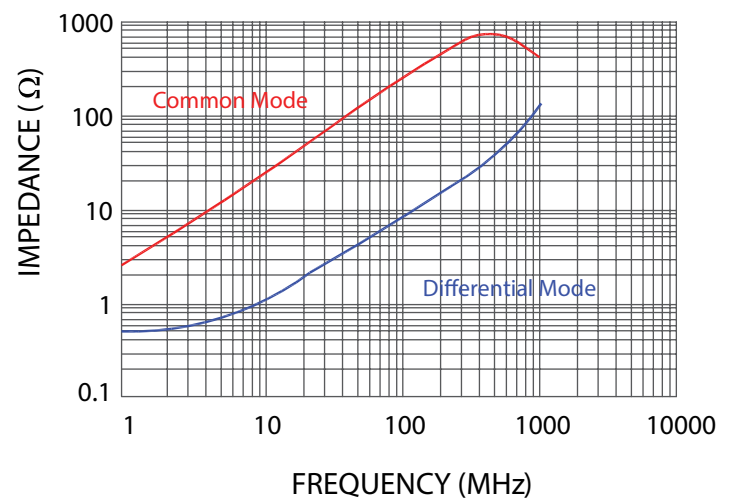

RENCO ELECTRONICS INC.

595 International Place, Rockledge, FL 32955-4200 USA • www.rencousa.com • ISO 9001 Certified
Toll Free Engineering Hot Line: 800.645.5828 • P: 321.637.1000 • F: 321.637.1600

RL-7900-2

RL-7900-2-260

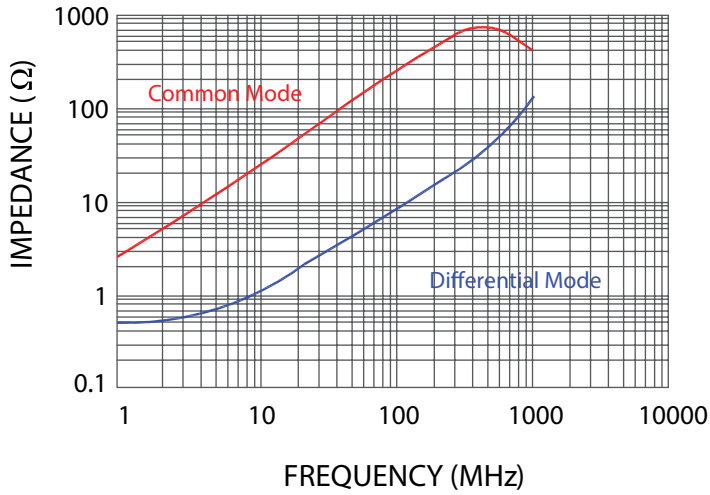

RL-7900-2-280

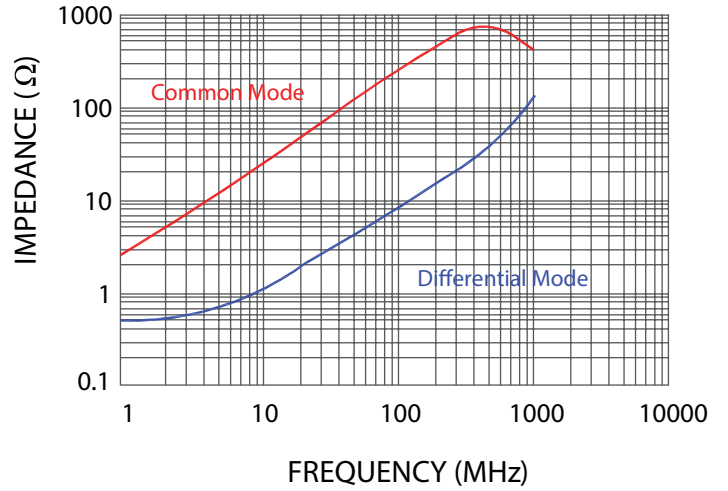

RL-7900-2-300

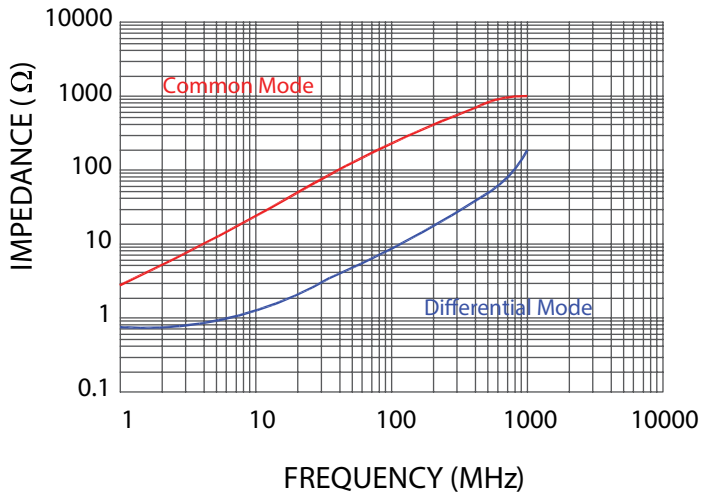

RL-7900-2-360

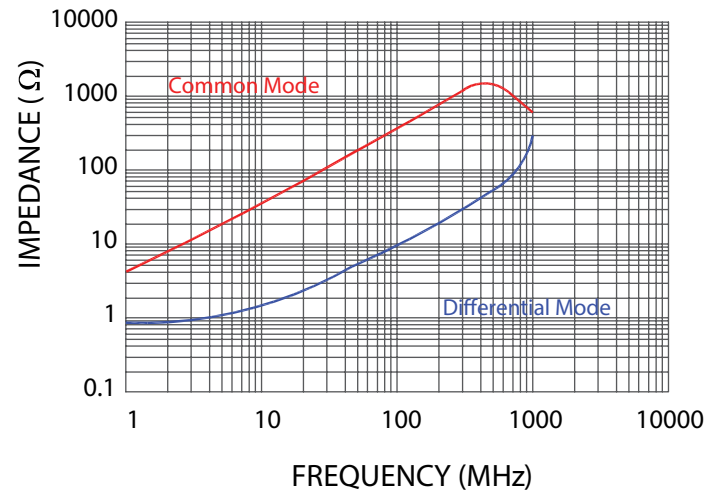

RL-7900-2

RL-7900-2-430

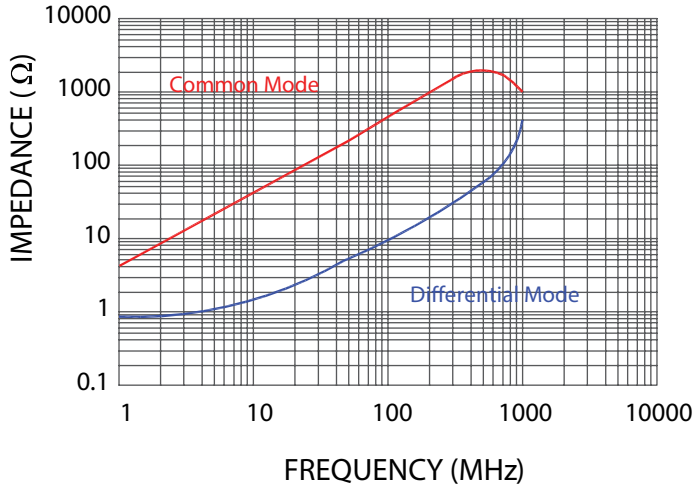

RL-7900-2-470

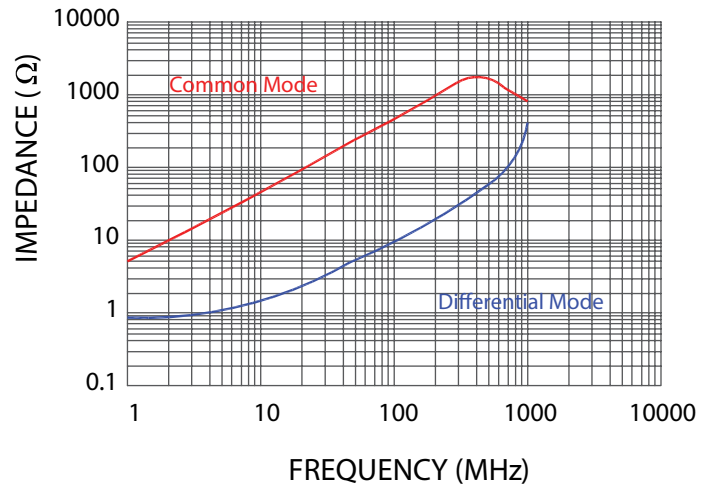

RL-7900-2-550

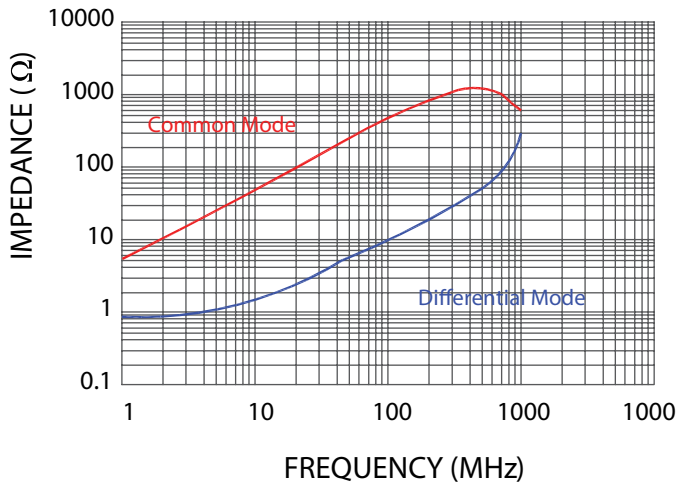

RL-7900-2-600

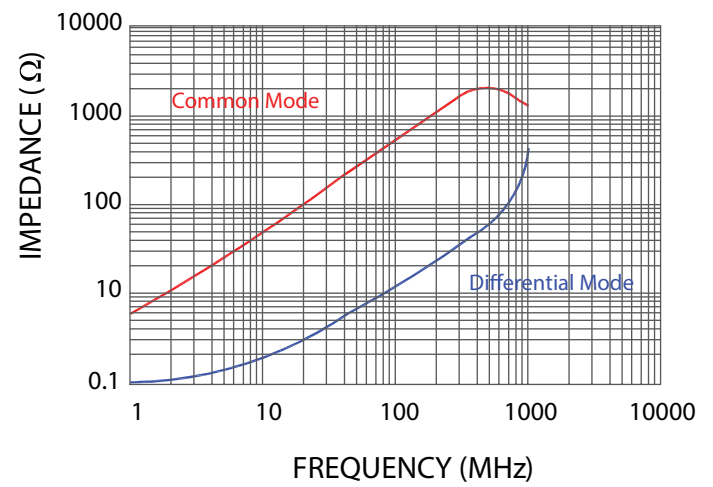

RL-7900-2-2200

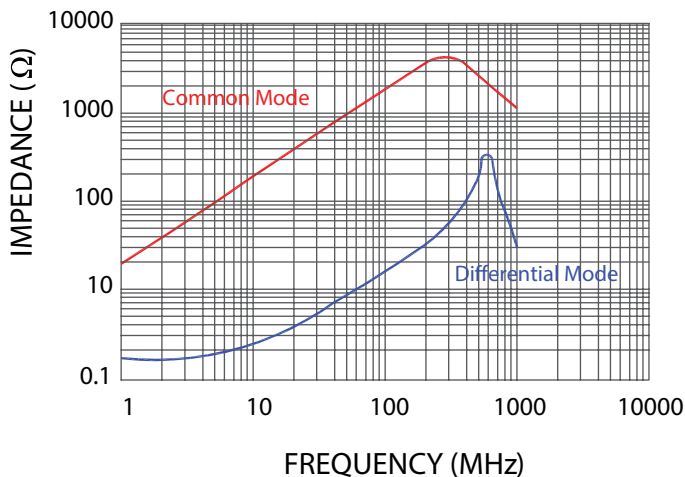

RENCO ELECTRONICS INC.

595 International Place, Rockledge, FL 32955-4200 USA • www.rencousa.com • ISO 9001 Certified
Toll Free Engineering Hot Line: 800.645.5828 • P: 321.637.1000 • F: 321.637.1600

