

**PLEASE CHECK WWW.MOLEX.COM FOR LATEST PART INFORMATION**

**Part Number:** [0005121102](#)  
**Status:** **Active**  
**Overview:** [flat blade](#)  
**Description:** Crimp Terminal 6482, 14-18 AWG, Reel

**Documents:**

[Drawing \(PDF\)](#) [RoHS Certificate of Compliance \(PDF\)](#)

**General**

Product Family	Crimp Terminals
Series	<a href="#">6482</a>
Crimp Quality Equipment	Yes
Overview	<a href="#">flat blade</a>
Product Name	Flat Blade

**Physical**

Gender	Female
Material - Metal	High Performance Alloy (HPA)
Material - Plating Mating	Unplated
Material - Plating Termination	Unplated
Packaging Type	Reel
Termination Interface: Style	Crimp or Compression
Wire Insulation Diameter	3.55mm(.140") max.
Wire Size AWG	14, 16, 18
Wire Size mm <sup>2</sup>	14 TO 18

**Material Info**

Old Part Number	6482-1
-----------------	--------

**Reference - Drawing Numbers**

Sales Drawing	SD-6482-1*
---------------	------------

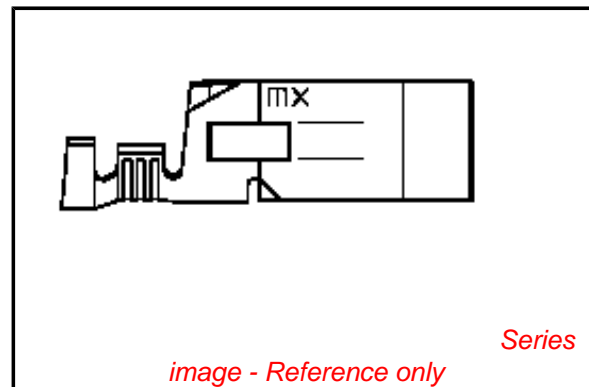

**EU RoHS**

**ELV and RoHS  
Compliant**  
**REACH SVHC  
Not Reviewed**  
**Halogen-Free  
Status  
Not Reviewed**

**China RoHS**



**Need more information on product  
environmental compliance?**

Email [productcompliance@molex.com](mailto:productcompliance@molex.com)  
 For a multiple part number RoHS Certificate of  
 Compliance, [click here](#)

Please visit the [Contact Us](#) section for any  
 non-product compliance questions.

**Search Parts in this Series**

[6482Series](#)

**Application Tooling | [FAQ](#)**

*Tooling specifications and manuals are  
 found by selecting the products below.  
 Crimp Height Specifications are then  
 contained in the Application Tooling  
 Specification document.*

**Global**

Description	Product #
Mini-Mac™ Applicator	<a href="#">0011182036</a>
Terminator Die	<a href="#">0011402151</a>
Manual Extraction Tool	<a href="#">0638131100</a>

SD-6482-1\*

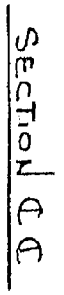
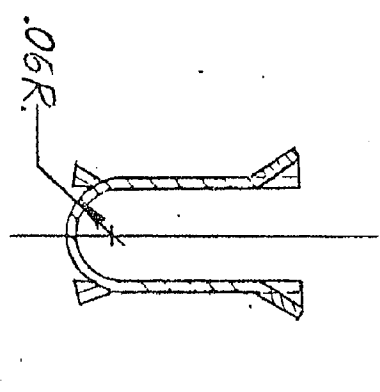
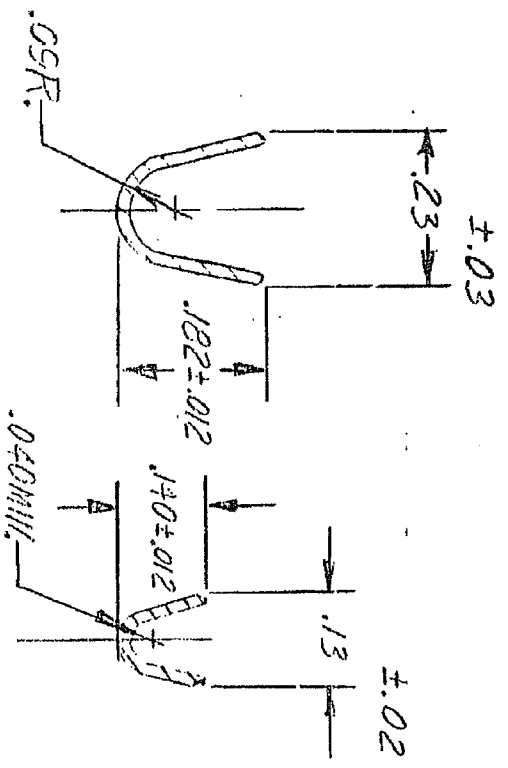
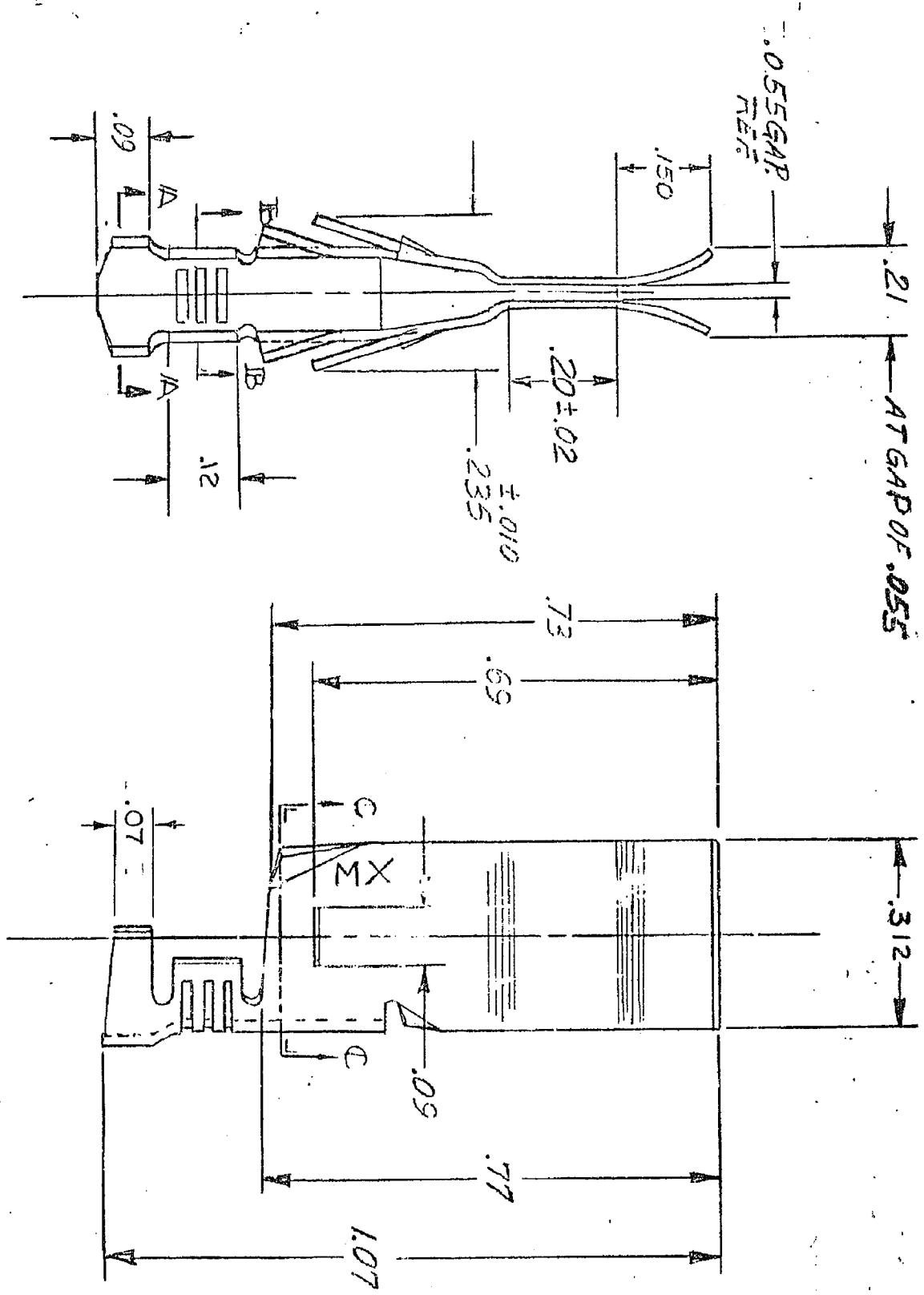

NOTES:  
 ▲ FOR CRIMPING 14 TO 18 A.W.G. WIRE.

PART No	ENG No	DESCRIPTION
05-12-1102	6482-1	CHAIN

MATERIAL:  
 BRONZE, HIGH TEMPERATURE, .016 THICK.

D	DELETE PART NO. ECR U2-1706 23-01-20 AG
C	.07 ADDED. ECR U8-2273 11-29-88 MB
B	REVISE MAT'L. CALLOUT BRONZE WAS BRASS & ADD EDP NO. TO 6482-1L PER ERO # 22731 6-12-86 JCS MB
A	ADD EDP # TO 6482-1 PER ERO # 19397 10-5-84 JCS
1	X-RELEASE PER ERO # 14276 10-12-81 JOK

REVISIONS

UNLESS OTHERWISE SPECIFIED  
 TOLERANCES:  
 3-PLACE DEC. DIMS ± .010  
 2-PLACE DEC. DIMS ± .014  
 ANGULAR ± 1/2°  
 DRAFT WHEN APPLICABLE MUST REMAIN WITHIN DIRECTIONS, UNLESS OTHERWISE SPECIFIED.  
 DO NOT SCALE DRAWING

TERMINAL  
 MOLEX PRODUCTS CO.  
 DOWNERS GROVE, ILL. 60515, U.S.A.  
 DATE 10-12-81  
 SD-6482-1\*

THIS DRAWING CONTAINS INFORMATION THAT IS PROPRIETARY TO THE MOLEX PRODUCTS COMPANY AND SHOULD NOT BE USED WITHOUT WRITTEN PERMISSION.