

Remote I/O R6 Series

CC-Link INTERFACE MODULE

(CC-Link Ver.1.10; for 16-point analog signals)

Functions & Features

- Free combination of analog and discrete I/O
- Direct sensor inputs
- Space-saving
- Low power consumption

Typical Applications

- Remote I/O for DCS and PLC

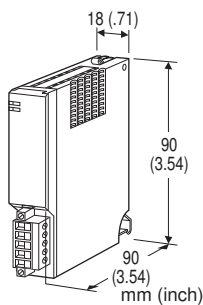

MODEL: R6-NC1[1]

ORDERING INFORMATION

- Code number: R6-NC1[1]
- Specify a code from below for [1].
(e.g. R6-NC1/Q)
- Specify the specification for option code /Q
(e.g. /C01)

[1] OPTIONS

blank: none

/Q: With options (specify the specification)

SPECIFICATIONS OF OPTION: Q

COATING (For the detail, refer to M-System's web site.)

/C01: Silicone coating

/C02: Polyurethane coating

PACKAGE INCLUDES...

- Terminating resistor (110 Ω, 0.5 W)

GENERAL SPECIFICATIONS

Connection

Network: Euro type connector terminal
(applicable wire size: 0.2 to 2.5 mm², stripped length 7 mm)

Internal bus: Via the Installation Base (model: R6x-BS)

Internal power: Via the Installation Base (model: R6x-BS)

Max. number of I/O modules: 16 (analog 16 points)

Isolation: CC-Link to internal bus or internal power

RUN indicator: Bi-color (green/red) LED; green in normal communications; red when receiving (Function selected with DIP SW)

ERR indicator: Bi-color (green/red) LED; the green ON/ blinks in communication errors; red when transmitting (Function selected with DIP SW)

Data allocation: Mode 1 or 2 set with the side DIP switch

CC-Link COMMUNICATION

Protocol: CC-Link V1.10

Device type: Remote device station

Required node: 4 (RX, RY: 32 bit, RWw, RWr: 16 words)

Network cable: CC-Link cable

Station No. setting: Rotary switch; 1 - 64

Baud rate setting: Rotary switch
156kbps, 625kbps, 2.5Mbps, 5Mbps, 10Mbps

INSTALLATION

Operating temperature: -10 to +55°C (14 to 131°F)

Operating humidity: 30 to 90 %RH (non-condensing)

Atmosphere: No corrosive gas or heavy dust

Mounting: Installation Base (model: R6x-BS)

Weight: 100 g (3.53 oz)

PERFORMANCE

Insulation resistance: ≥ 100 MΩ with 500 V DC

Dielectric strength: 2000 V AC @ 1 minute (CC-Link to internal bus or internal power)

STANDARDS & APPROVALS

Refer to the manuals to comply with the standards.

EU conformity:

EMC Directive

EMI EN 61000-6-4

EMS EN 61000-6-2

RoHS Directive

EN 50581

EXTERNAL VIEW

■ SIDE VIEW

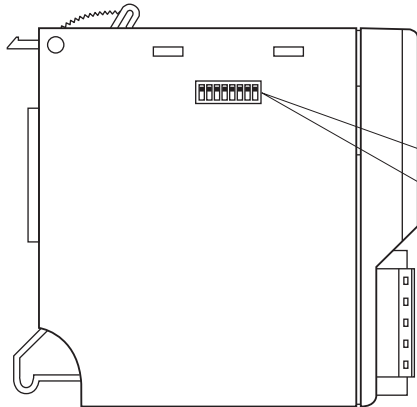

■ FRONT VIEW

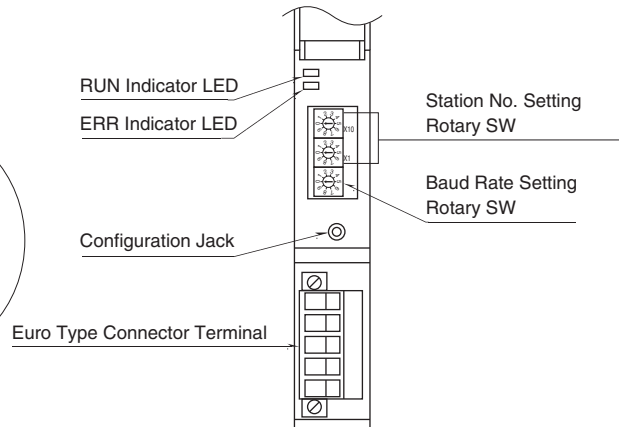

COMMUNICATION CABLE CONNECTIONS

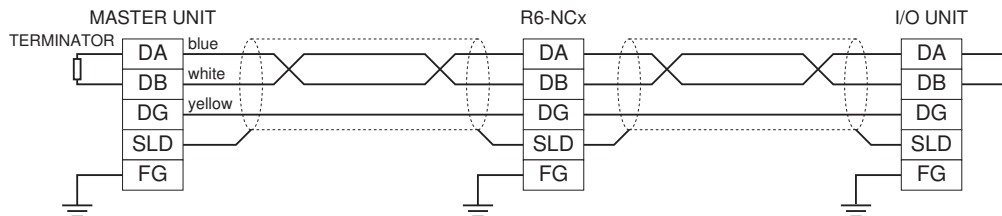

TRANSMISSION DATA DESCRIPTIONS

The DIP SW located at the side of the module switches the unit's data allocation mode.

In the Data Allocation Mode 1, one (1) word is assigned per module. The second channel of analog I/O modules cannot be used. Max. 16 I/O modules can be connected in this mode.

In the Data Allocation Mode 2, two (2) words are assigned per module regardless of whether the second word area is required or not, even for discrete I/O modules that require one (1) word.

Max. 8 I/O modules can be connected in this mode.

■ DATA ALLOCATION MODE 1

• Output Data

The figure below shows the allocation of data sent from the network module to the master.

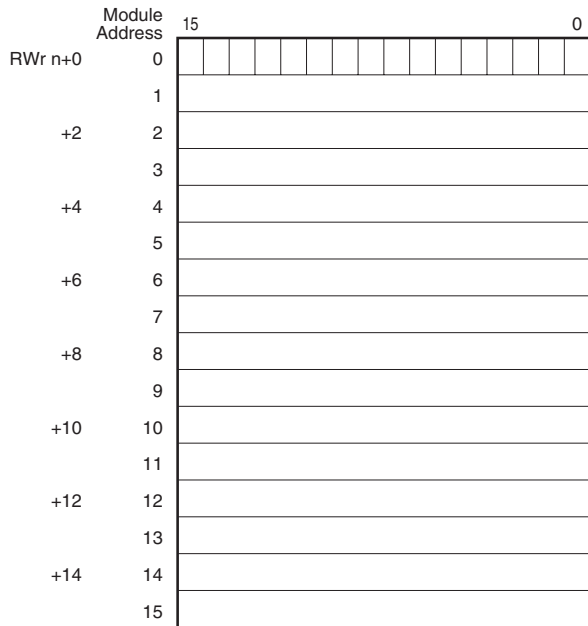

• Input Data

The figure below shows the allocation of data sent from the master to the network module.

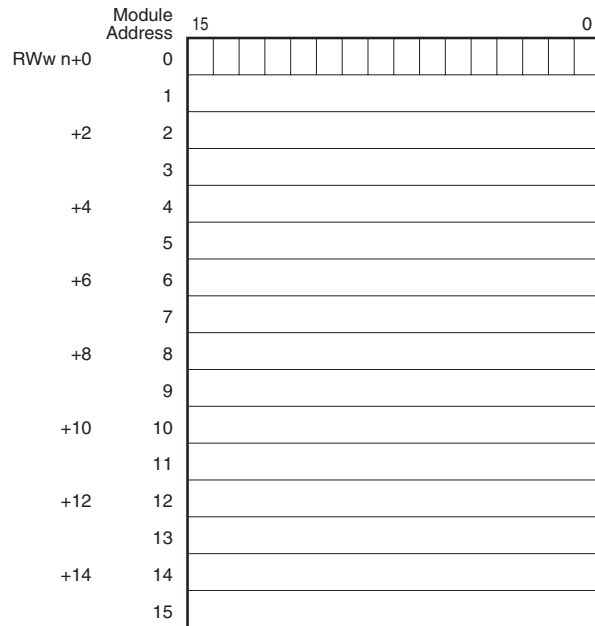

Each module takes one-word areas for input and output respectively, regardless of whether the module type is input or output.

If a module for Data Allocation Mode 2 is used, the second channel data is invalid.

Field input data is set in the module's output data area. The input data area is also secured though not used for an input module.

• RX(n+0)0 through RX(n+0)F

RX(n+0)0 through RX(n+0)F show the I/O module's data error.

- Input overrange ($\leq -15\%$ or $\geq 115\%$) of Input modules except R6x-TSx and R6x-RSx.
- Inputs of R6x-TSx, R6x-RSx burnout.
- Output wire breakdown of R6x-YSx (Firmware Version 2.00 or later). *

In the above case, the corresponded bit is "1."

Also the corresponded bit for unmounted channels is "1."

RX(n+0) 0	Module address 0
RX(n+0) 1	Module address 1
RX(n+0) 2	Module address 2
RX(n+0) 3	Module address 3
⋮	⋮
⋮	⋮
RX(n+0) E	Module address 14
RX(n+0) F	Module address 15

• RX(n+1)0 through RX(n+1)F

RX(n+1)0 through RX(n+1)7 are reserved for future use. RX(n+1)8 through RX(n+1)A and RX(n+1)C through RX(n+1)F are not used, while RX(n+1)B is assigned to Ready signal, which is turned to "1" when the network module is in normal conditions.

* R6-NC1 is compatible with Firmware version 1.02 or later.

■ DATA ALLOCATION MODE 2

• Output Data

The figure below shows the allocation of data sent from the network module to the master.

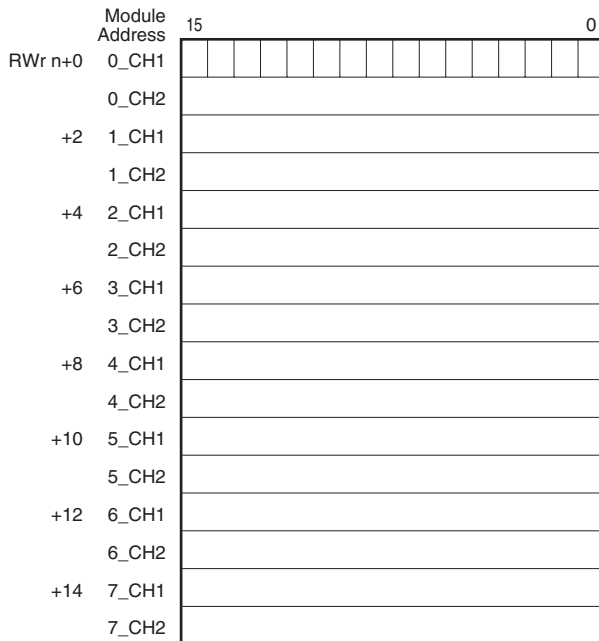

• Input Data

The figure below shows the allocation of data sent from the master to the network module.

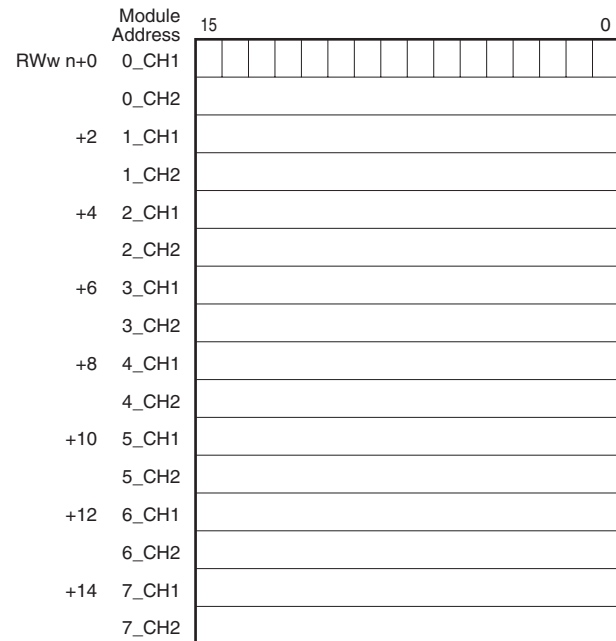

Each module takes two-word areas for input and output respectively, regardless of whether the module type is input or output. If a module for Data Allocation Mode 1 is used, all the bits for the second channel data turn to "0" (unused). Field input data is set at the module's output data area. The input data area is also secured though not used for an input module.

• RX(n+0)0 through RX(n+0)F

RX(n+0)0 through RX(n+0)F show the I/O module's data error.

- Input overrange ($\leq -15\%$ or $\geq 115\%$) of Input modules except R6x-TSx and R6X-RSx.
- Inputs of R6x-TSx, R6x-RSx burnout.
- Output wire breakdown of R6x-YSx (Firmware Version 2.00 or later). *

In the above case, the corresponded bit is "1."

The allocation using R6-NC1 with modules all of which data allocation is "2" is shown below.

RX(n+0) 0	Module address 0, I/O 1
RX(n+0) 1	Module address 0, I/O 2
RX(n+0) 2	Module address 1, I/O 1
RX(n+0) 3	Module address 1, I/O 2
⋮	⋮
⋮	⋮
RX(n+0) E	Module address 7, I/O 1
RX(n+0) F	Module address 7, I/O 2

• RX(n+1)0 through RX(n+1)F

RX(n+1)0 through RX(n+1)7 are reserved for future use. RX(n+1)8 through RX(n+1)A and RX(n+1)C through RX(n+1)F are not used, while RX(n+1)B is assigned to Ready signal, which is turned to "1" when the network module is in normal conditions.

* R6-NC1 is compatible with Firmware version 1.02 or later.

I/O DATA DESCRIPTIONS

■ 16-BIT ANALOG DATA

0 to 100% of the selected I/O range is converted into 0 to 10000 (binary).

With °C or Kelvin temperature unit, raw data is multiplied by 10. For example, 25.5°C is converted into 255.

With °F temperature unit, the integer section of raw data is directly converted into the data. For example, 135.4°F is converted into 135.

Negative values are represented in 2's complements.



■ DISCRETE DATA

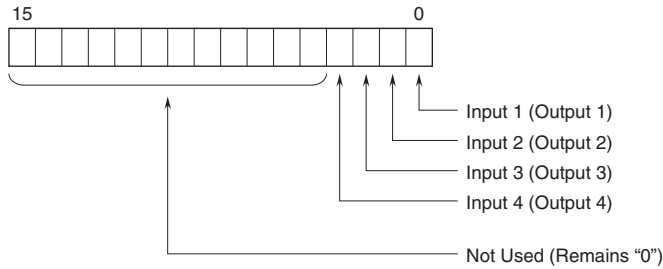

0 : OFF
1 : ON

EXTERNAL DIMENSIONS unit: mm (inch)

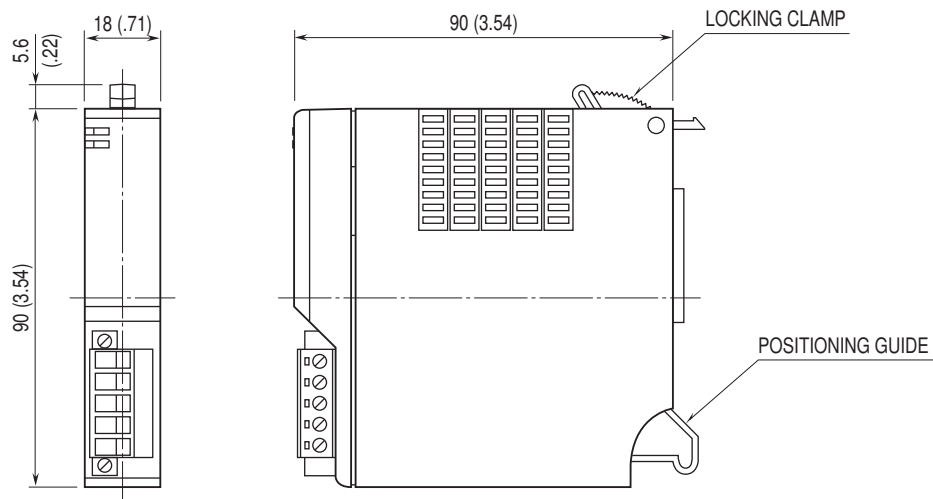

SCHEMATIC CIRCUITRY & CONNECTION DIAGRAM

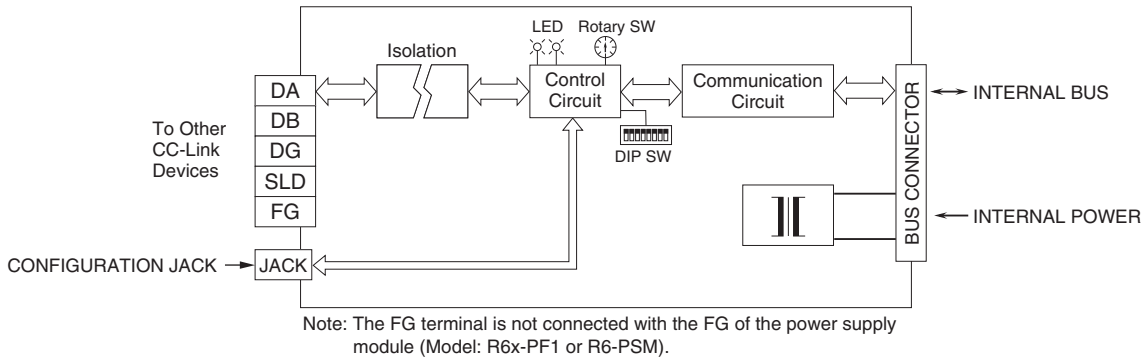

Specifications are subject to change without notice.