

High-density Signal Conditioners 10-RACK**SIGNAL TRANSMITTER**

(field-programmable)

Functions & Features

- Converting a DC input into two standard process signals
- Micro-processor based
- Field-programmable input range
- Loop testing via hand-held programmer PU-2x
- Optional second channel output available at the front terminals and at the Standard Rack connector

Typical Applications

- Isolation between control room and field instrumentation
- Ideal for quick spare part

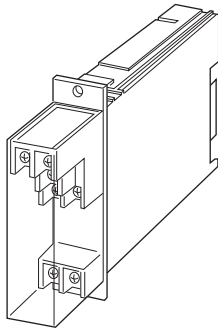
**MODEL: 10JV-[1][2][3]-R[4]****ORDERING INFORMATION**

- Code number: 10JV-[1][2][3]-R[4]

Specify a code from below for each [1] through [4].

- (e.g. 10JV-6A6-R/Q)
- Special input range (For codes U1, U2 & U3)
- Specify the specification for option code /Q (e.g. /C01)

[1] INPUT**Current****A:** 4 - 20 mA DC (Input resistance 250 Ω)**H:** 10 - 50 mA DC (Input resistance 100 Ω)**Voltage****6:** 1 - 5 V DC (Input resistance 1 MΩ min.)**U1:** Range ±100 mV;

(Minimum span 3 mV, Input resistance 20 kΩ min.)

U2: Range ±1000 mV;

(Minimum span 30 mV, Input resistance 20 kΩ min.)

U3: Range ±10 V;

(Minimum span 0.3 V, Input resistance 1 MΩ min.)

[2] OUTPUT 1**Current****A:** 4 - 20 mA DC (Load resistance 600 Ω max.)**Voltage****6:** 1 - 5 V DC (Load resistance 500 Ω min.)**[3] OUTPUT 2****0:** None**Voltage****6:** 1 - 5 V DC (Load resistance 5000 Ω min.)**POWER INPUT****DC Power****R:** 24 V DC

(Operational voltage range 24 V ±10 %, ripple 10 %p-p max.)

[4] OPTIONS**blank:** none**/Q:** With options (specify the specification)**SPECIFICATIONS OF OPTION: Q****COATING (For the detail, refer to M-System's web site.)****/C01:** Silicone coating**/C02:** Polyurethane coating**/C03:** Rubber coating**RELATED PRODUCTS**

- Programming Unit (model: PU-2x)
- PC configurator software (model: JXCON)

Downloadable at M-System's web site.

A dedicated cable is required to connect the module to the PC. Please refer to the internet software download site or the users manual for the PC configurator for applicable cable types.

GENERAL SPECIFICATIONS

Construction: Rack-mounted; terminal access via screw terminals at the front and via card-edge connector at the rear; terminal cover provided

Connection**Input:** M3.5 screw terminals (torque 0.8 N·m)**Output:** Card-edge connector and M3.5 screw terminals (torque 0.8 N·m)**Power input:** Supplied from card-edge connector**Screw terminal:** Nickel-plated steel**Housing material:** Flame-resistant resin (black)**Isolation:** Input to output 1 to output 2 to power**Overrange output:** Approx. -10 to +120 % at 1 - 5 V**Adjustments:** Programming Unit (model: PU-2x); Input

range, zero and span, simulating output, etc.
(Input range can be changed with Codes U1, U2 or U3 and limited within ranges of each code type.)
(Refer to the users manual of JXCON for the adjustments configurable with JXCON.)

INPUT SPECIFICATIONS

- **DC Current:** Input resistor incorporated
 - **DC Voltage:** -10 - +10 V DC
 - Minimum span:** 3 mV
 - Offset:** Max. 3 times span
- Default setting will be used if not otherwise specified.
- U1:** 0 - 100 mV DC
 - U2:** 0 - 1 V DC
 - U3:** 0 - 10 V DC

OUTPUT SPECIFICATIONS

With the input voltage code 6, U3 (0 % \geq 0 V) and current, the output goes below 0 % when the input is open.

INSTALLATION

- Current consumption:** Approx. 60 mA with voltage output 1
Approx. 90 mA with current output 1
- Operating temperature:** -5 to +55°C (23 to 131°F)
- Operating humidity:** 30 to 90 %RH (non-condensing)
- Mounting:** Standard Rack 10BXx
- Weight:** 220 g (0.49 lb)

PERFORMANCE in percentage of span

- Accuracy:** ± 0.1 %
- Temp. coefficient:** ± 0.015 %/°C (± 0.008 %/°F)
- Response time:** ≤ 0.5 sec. (0 - 90 %)
- Line voltage effect:** ± 0.1 % over voltage range
- Insulation resistance:** ≥ 100 M Ω with 500 V DC
- Dielectric strength:** 500 V AC @ 1 minute
(input to output 1 to output 2 to power)
1500 V AC @ 1 minute (input or output or power to ground)

EXTERNAL DIMENSIONS & TERMINAL ASSIGNMENTS unit: mm (inch)

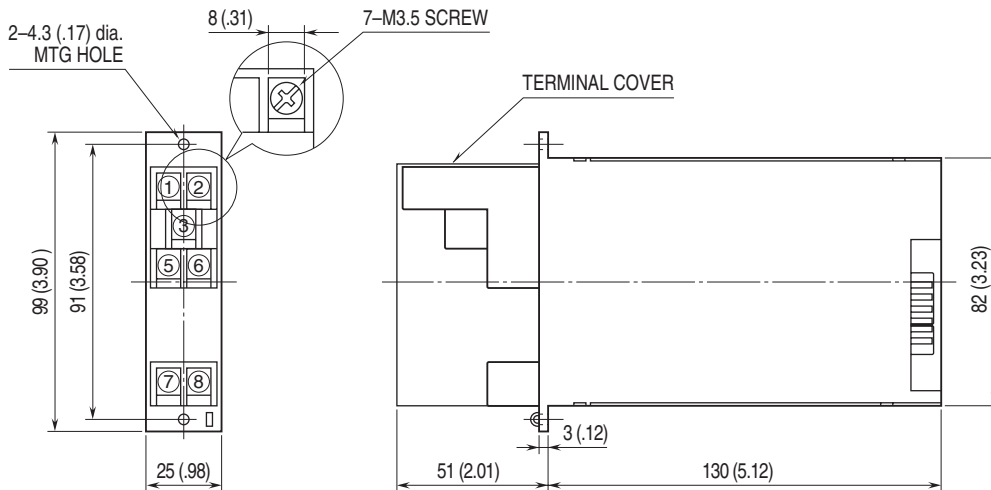

SCHEMATIC CIRCUITRY & CONNECTION DIAGRAM

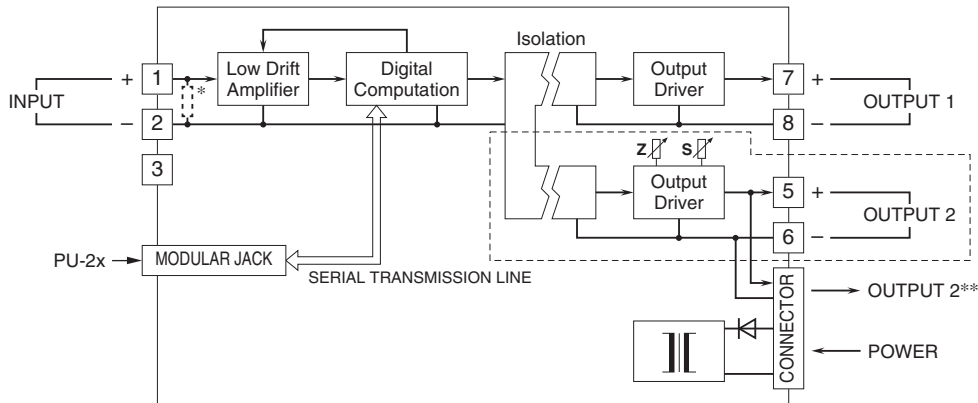

* Input shunt resistor incorporated for current input.
 **1 output type has the output 1 connected to the card-edge connector in parallel.
 Remark 1) The section enclosed by broken line is only for 2nd output channel.



Specifications are subject to change without notice.