

## FRED Ultrafast Soft Recovery Diode 100A x 2 / 1200V



### FEATURES

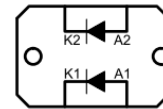
- Fast recovery time characteristic
- Electrically isolated base plate
- Large creepage distance between terminal
- Simplified mechanical designs, rapid assembly
- Compliant to RoHS
- Designed and for industrial level



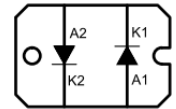
### DESCRIPTION

This SOT-227 modules with FRED rectifier are available in two basic configurations. They are the antiparallel and the parallel configurations. The antiparallel configuration NST200F12-A is used for simple series rectifier and high voltage application. The parallel configuration NST200F12 is used for simple parallel rectifier and high current application. The semiconductor in the SOT-227 package is isolated from the copper base plate, allowing for common heatsinks and compact assemblies to be built. These modules are intended for general applications such as power supplies, battery chargers, electronic welders, motor control, DC chopper, and inverters.

### CIRCUIT CONFIGURATION



Parallel  
NST200F12



Anti-Parallel  
NST200F12-A

### APPLICATIONS

- Switching power supplies
- Inverters
- Motor controllers
- Converters
- Snubber diodes
- Uninterruptible power supplies (UPS)
- Induction heating
- High speed rectifiers

### PRODUCT SUMMARY

$V_R$	1200 V
$V_F$ (typical) at 125 °C	1.7 V
$t_{rr}$ (typical)	55 ns
$I_{F(DC)}$ at $T_C$ per diode	93A at 80 °C

### ABSOLUTE MAXIMUM RATINGS

PARAMETER	SYMBOL	TEST CONDITIONS	VALUES	UNITS
Cathode to anode voltage	$V_R$		1200	V
Maximum continuous forward current $\frac{\text{per leg}}{\text{per module}}$	$I_F$	$T_C = 80\text{ °C}$ , Duty cycle = 0.5	93	A
			186	
Single pulse forward current	$I_{FSM}$	$T_J = 25\text{ °C}$	1000	
RMS isolation voltage, any terminal to case	$V_{ISOL}$	$t = 1\text{ minute}$	2500	V
Maximum power dissipation	$P_D$	$T_C = 25\text{ °C}$	440	W
		$T_C = 100\text{ °C}$	260	
Operating junction and storage temperature range	$T_J, T_{Stg}$		- 55 to 175	°C

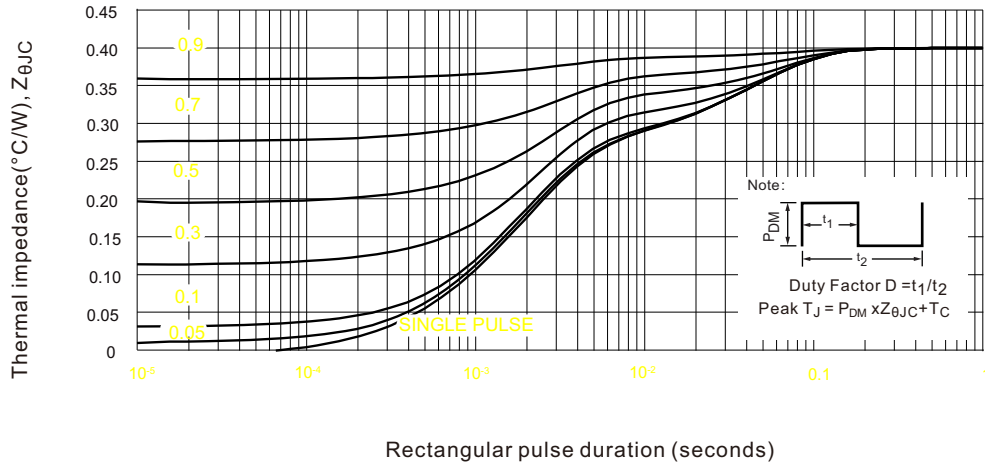
## Nell High Power Products

ELECTRICAL SPECIFICATIONS (T <sub>J</sub> = 25 °C unless otherwise specified)						
PARAMETER	SYMBOL	TEST CONDITIONS	MIN.	TYP.	MAX.	UNITS
Cathode to anode breakdown voltage	V <sub>BR</sub>	I <sub>R</sub> = 100 μA	1200	-	-	V
Maximum forward voltage	V <sub>FM</sub>	I <sub>F</sub> = 100 A	-	1.90	2.20	
		I <sub>F</sub> = 200 A	-	2.30	-	
Maximum reverse leakage current	I <sub>RM</sub>	V <sub>R</sub> = V <sub>R</sub> rated	-	0.2	10	μA
		T <sub>J</sub> = 125 °C, V <sub>R</sub> = V <sub>R</sub> rated	-	-	0.5	mA
Junction capacitance	C <sub>J</sub>	V <sub>R</sub> = 200V	120			pF

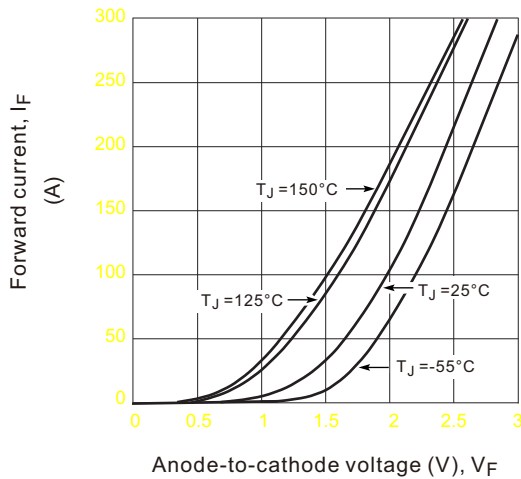
DYNAMIC RECOVERY CHARACTERISTICS PER LEG (T <sub>J</sub> = 25 °C unless otherwise specified)						
PARAMETER	SYMBOL	TEST CONDITIONS	MIN.	TYP.	MAX.	UNITS
Reverse recovery time	t <sub>rr</sub>	I <sub>F</sub> = 0.5A, I <sub>R</sub> = 1.0A, I <sub>RR</sub> = 250mA (RG#1 CKT)	-	105	120	ns
		I <sub>F</sub> = 1.0 A, di <sub>F</sub> /dt = -100 A/μs, V <sub>R</sub> = 30 V, T <sub>J</sub> = 25 °C	-	55	-	
	t <sub>rr1</sub>	T <sub>J</sub> = 25 °C	-	420	-	
Reverse recovery time	t <sub>rr2</sub>	T <sub>J</sub> = 125 °C	-	580	-	A
	I <sub>RRM1</sub>	T <sub>J</sub> = 25 °C	-	7	-	
Reverse recovery time	I <sub>RRM2</sub>	T <sub>J</sub> = 125 °C	-	19	-	nC
	Q <sub>rr1</sub>	T <sub>J</sub> = 25 °C	-	1250	-	
Reverse recovery time	Q <sub>rr2</sub>	T <sub>J</sub> = 125 °C	-	5350	-	

THERMAL - MECHANICAL SPECIFICATIONS (T <sub>J</sub> = 25 °C unless otherwise specified)						
PARAMETER	SYMBOL	MIN.	TYP.	MAX.	UNITS	
Junction to case, single leg conducting	R <sub>thJC</sub>	-	-	0.40	°C/W K/W	
Junction to case, both legs conducting		-	-	0.20		
Case to sink, flat, greased surface	R <sub>thCS</sub>	-	0.05	-		
Weight		-	30	-	g	
Mounting torque		-	-	1.1	Nm	

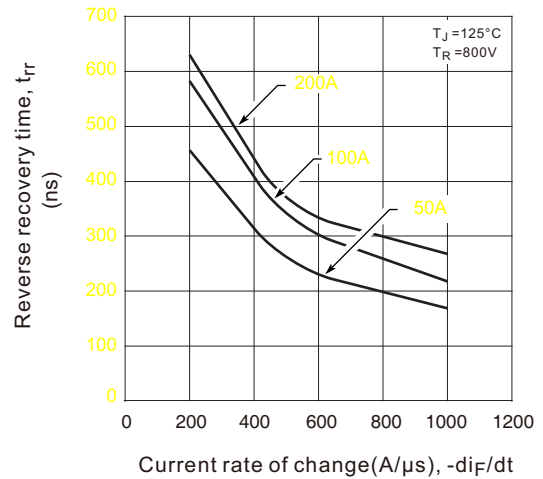
**Fig.1 Maximum effective transient thermal impedance, junction-to-case vs. pulse duration**



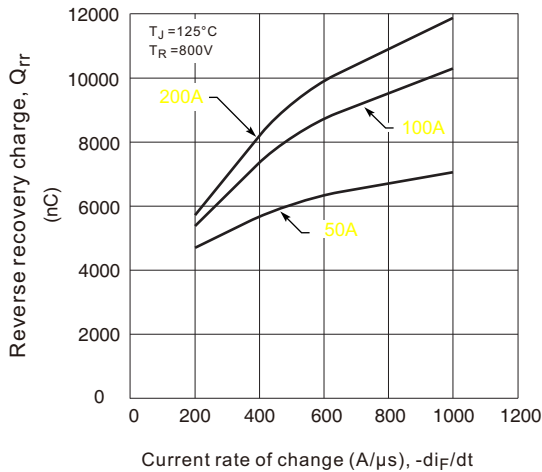
**Fig.2 Forward current vs. forward voltage**



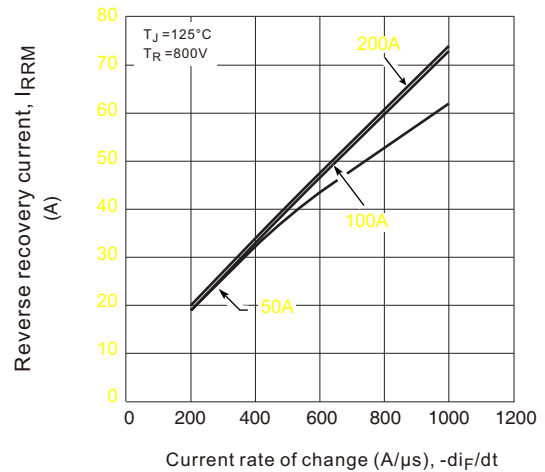
**Fig.3 Reverse recovery time vs. current rate of change**



**Fig.4 Reverse recovery charge vs. current rate of change**

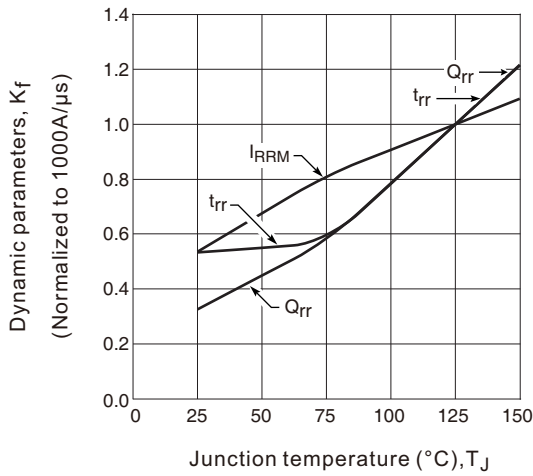


**Fig.5 Reverse recovery current vs. current rate of change**

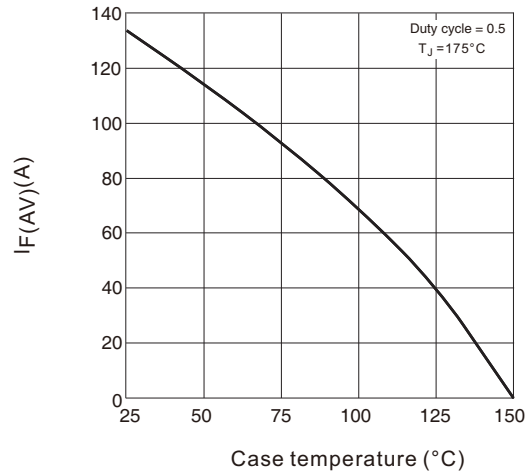


## Nell High Power Products

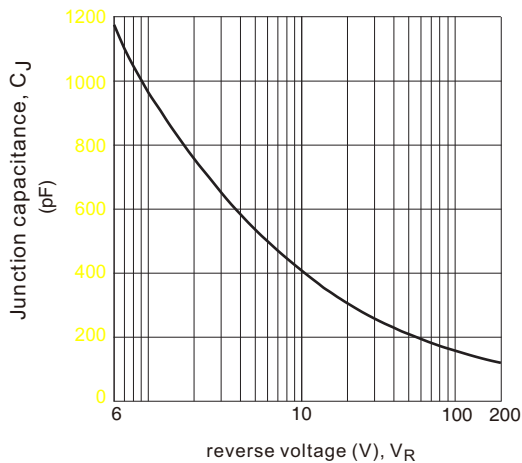
**Fig.6. Dynamic parameters vs. junction temperature**



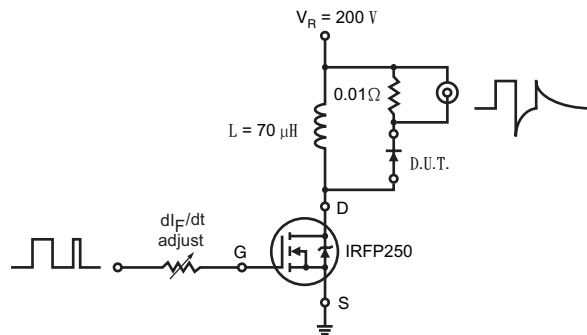
**Fig.7 Maximum average forward current vs. case temperature**



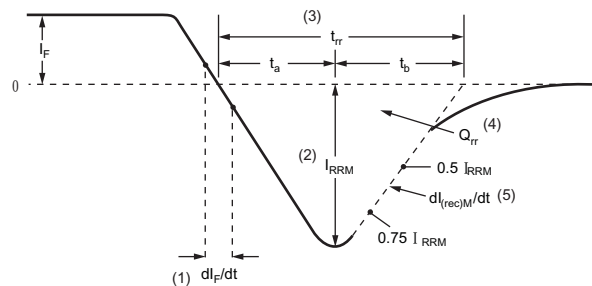
**Fig.8 Junction capacitance vs. reverse voltage**



**Fig.9 Reverse recovery parameter test circuit**



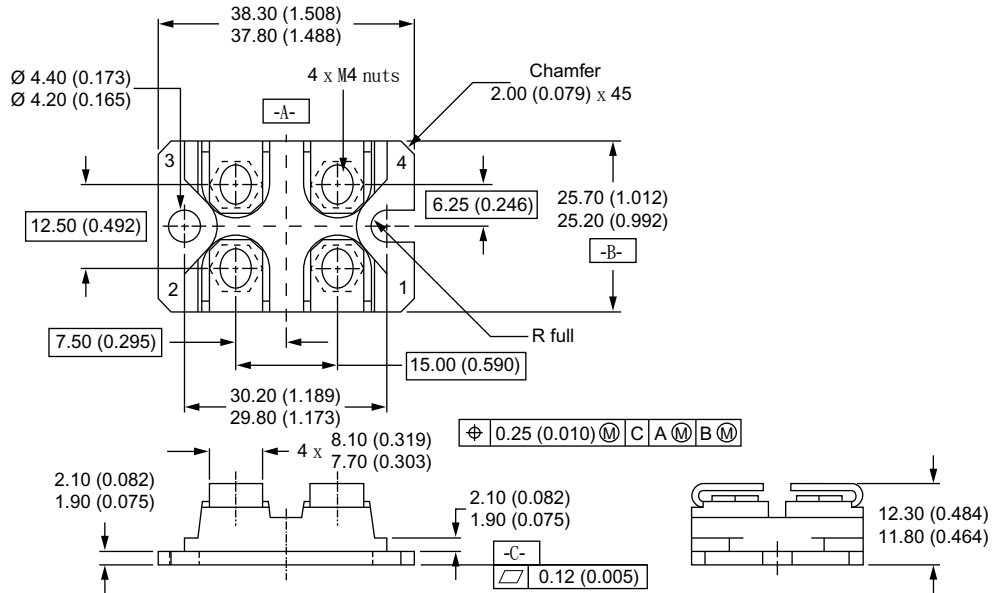
**Fig.10 Reverse recovery waveform and definitions**



- (1)  $dI_F/dt$  - rate of change of current through zero crossing
- (2)  $I_{RRM}$  - peak reverse recovery current
- (3)  $t_{rr}$  - reverse recovery time measured from zero crossing point of negative going  $I_F$  to point where a line passing through  $0.75 I_{RRM}$  and  $0.50 I_{RRM}$  extrapolated to zero current.
- (4)  $Q_{rr}$  - area under curve defined by  $t_{rr}$  and  $I_{RRM}$
- (5)  $dI_{(rec)M}/dt$  - peak rate of change of current during  $t_b$  portion of  $t_{rr}$

$$Q_{rr} = \frac{t_{rr} \cdot I_{RRM}}{2}$$

### SOT-227



All dimensions in millimeters (inches)

#### Notes

- Dimensioning and tolerancing per ANSI Y14.5M-1982
- Controlling dimension: millimeter

### ORDERING INFORMATION TABLE

Device code	<b>N</b>	<b>ST</b>	<b>200</b>	<b>F</b>	<b>12</b>	<b>-</b>	<b>A</b>
	①	②	③	④	⑤		⑥

- ① - Nell High Power Products
- ② - Package indicator (SOT-227)
- ③ - Current rating (200 = 200A, 100A x 2)
- ④ - F = FRED family
- ⑤ - Voltage rating (12 = 1200 V)
- ⑥ - Circuit type, A for Anti-Parallel type  
Blank for parallel type.