

---

**OKI Semiconductor**

---

**MR53V8052J****Preliminary**

---

**524,288-Word X 16-Bit or 1,048,576-Word X 8-Bit****8Word X 16-Bit or 16Word X 8-Bit/Page Mode MASK ROM**

---

**DESCRIPTION**

The MR53V8052J is a 8Mbit Read-Only Memory whose configuration can be electrically switched between 524,288 word x 16bit and 1,048,576 word x 8bit. The MR53V8052J operates asynchronously, external clocks are not required, making this device easy-to-use. The MR53V8052J is suitable as large-capacity fixed memory for microcomputers and data terminals. It is manufactured using a CMOS silicon gate technology and is offered in 42-pin DIP, 44-pin SOP or 44-pin TSOP packages.

**FEATURES**

- 524,288 word x 16bit / 1,048,576 word x 8bit electrically switchable configuration
- 8word x 16-Bit or 16word x 8-bit / Page read mode
- Single +2.7V~3.6V power supply
- Normal access time           100ns
- Page access time             30ns
- V<sub>CC</sub> power supply current   80mA
- V<sub>CC</sub> standby current         10μA
- Input / Output TTL compatible
- Three-state output
- Packages
  - 42-pin plastic DIP   (DIP42-P-600-2.54)   MR53V8052J-XXRA
  - 44-pin plastic SOP   (SOP44-P-600-1.27-K)   MR53V8052J-XXMA
  - 44-pin plastic TSOP  (TSOPII44-P-400-0.80-K) MR53V8052J-XXTP

PIN CONFIGURATION (TOP VIEW)

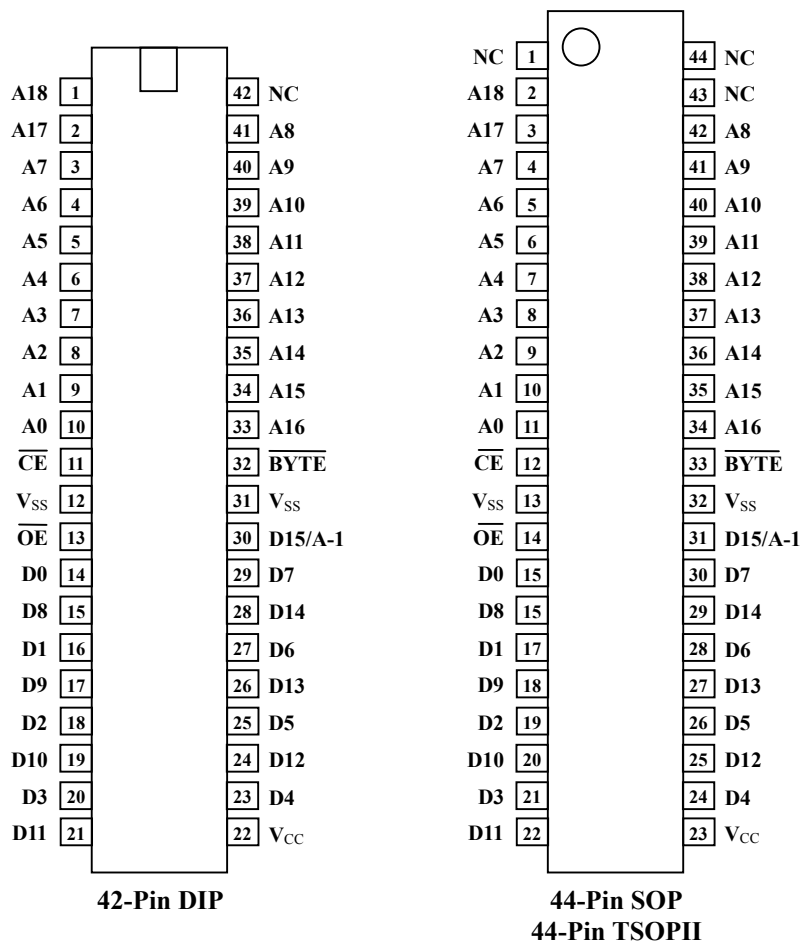

PIN NAMES	FUNCTIONS
D15/A-1	Data output / Address input
A0~A18	Address input
D0~D14	Data output
$\overline{CE}$	Chip enable
$\overline{OE}$	Output enable
$\overline{BYTE}$	Mode switch
V <sub>CC</sub>	Power supply voltage
V <sub>SS</sub>	GND
NC	Non connection

**BLOCK DIAGRAM**

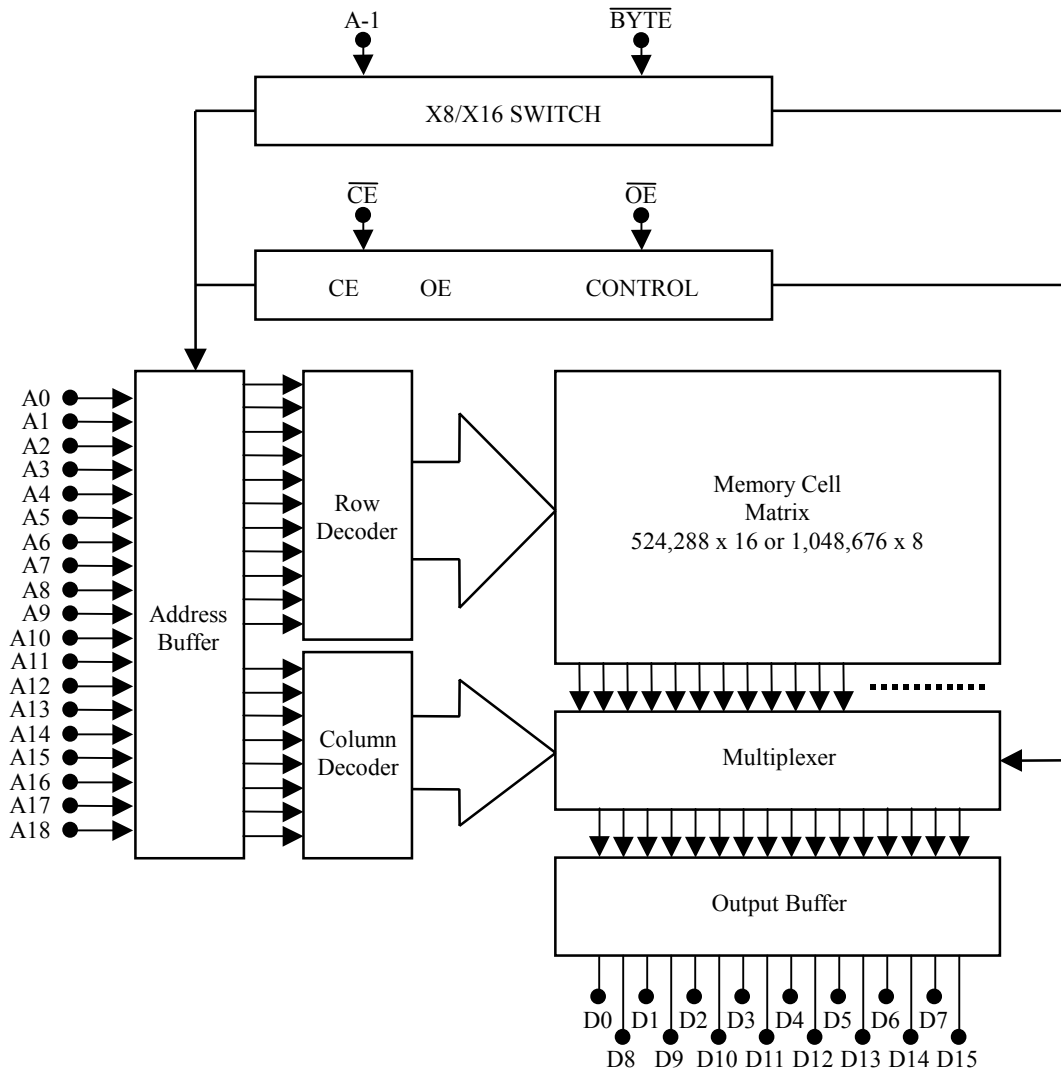

**FUNCTION TABLE**

MODE	$\overline{CE}$	$\overline{OE}$	$\overline{BYTE}$	D0~D7	D8~D14	A-1/D15
STAND BY	H	X	X	Hi-Z		
OUTPUT DISABLE	L	H	H	Hi-Z		
	L	H	L	L/H		
READ(16-BIT)	L	L	H	D <sub>OUT</sub>		
READ(8-BIT)	L	L	L	D <sub>OUT</sub>	Hi-Z	L/H

## ABSOLUTE MAXIMUM RATINGS

Parameter	Symbol	Condition	Value	Unit
Operating temperature under bias	T <sub>OPR</sub>	-	0 ~ 70	°C
Storage temperature	T <sub>STG</sub>	-	-55 ~ 125	°C
Input voltage	V <sub>I</sub>	Relative to V <sub>SS</sub>	-0.5 ~ V <sub>CC</sub> +0.5	V
Output voltage	V <sub>O</sub>		-0.5 ~ V <sub>CC</sub> +0.5	V
Power supply voltage	V <sub>CC</sub>		-0.5 ~ 5	V
Power dissipation per package	P <sub>D</sub>	-	1.0	W

## RECOMMENDED OPERATING CONDITIONS FOR READ

(Ta=0 ~ 70°C)

Parameter	Symbol	Condition	Min.	Typ.	Min.	Unit
V <sub>CC</sub> power supply voltage	V <sub>CC</sub>	V <sub>CC</sub> =2.7V ~ 3.6V	2.7	-	3.6	°C
Input "H" level	V <sub>IH</sub>		2.2	-	V <sub>CC</sub> +0.5	°C
Input "L" level	V <sub>IL</sub>		-0.5	-	0.8	V

Voltage is relative to V<sub>SS</sub>

## PIN Capacitance

(V<sub>CC</sub>=3.3V, Ta=25°C, f=1MHz)

Parameter	Symbol	Condition	Min.	Typ.	Min.	Unit
Input	C <sub>IN</sub>	V <sub>I</sub> =0V	-	-	12	pF
Output	C <sub>OUT</sub>	V <sub>O</sub> =0V	-	-	15	pF

**ELECTRICAL CHARACTERISTICS**

**DC Characteristics**

(V<sub>CC</sub>=2.7V~3.6V, Ta=0~70°C)

Parameter	Symbol	Condition	Min.	Typ.	Min.	Unit
Input leakage current	C <sub>IN</sub>	V <sub>I</sub> =0V~V <sub>CC</sub>	-	-	10	μA
Output leakage current	C <sub>OUT</sub>	V <sub>O</sub> =0V~V <sub>CC</sub>	-	-	10	μA
V <sub>CC</sub> power supply current (Standby)	I <sub>CCSC</sub>	$\overline{CE}=V_{CC}$	-	-	10	μA
	I <sub>CCST</sub>	$\overline{CE}=V_{IH}$	-	-	1	mA
V <sub>CC</sub> power supply current (Active)	I <sub>CCA</sub>	$\overline{CE}=V_{IL}, \overline{OE}=V_{IH}$ tc= 100ns	-	-	80	mA
Input "H" level	V <sub>IH</sub>	-	2.0	-	V <sub>CC</sub> +0.5	V
Input "L" level	V <sub>IL</sub>	-	-0.5	-	0.8	V
Output "H" level	V <sub>OH</sub>	I <sub>OH</sub> =-200 μA	V <sub>CC</sub> -0.4	-	-	V
Output "L" level	V <sub>OL</sub>	I <sub>OL</sub> =1mA	-	-	0.4	V

Voltage is relative to V<sub>SS</sub>

**AC Characteristics**

(V<sub>CC</sub>=2.7V~3.6V, Ta=0~70°C)

Parameter	Symbol	Condition	Min.	Min.	Unit
Address access cycle time	T <sub>C</sub>	-	100	-	ns
Address access time	T <sub>ACC</sub>	$\overline{CE}=\overline{OE}=V_{IL}$	-	100	ns
Page set up time	T <sub>PSET</sub>	NOTE.1	100	-	ns
Page access cycle time	T <sub>PC</sub>	-	30	-	ns
Page access time	T <sub>PAC</sub>	-	-	30	ns
$\overline{CE}$ access time	T <sub>CE</sub>	$\overline{OE}=V_{IL}$	-	100	ns
$\overline{OE}$ access time	T <sub>OE</sub>	$\overline{CE}=V_{IL}$	-	30	ns
Output disable time	T <sub>CHZ</sub>	$\overline{OE}=V_{IL}$	0	30	ns
	T <sub>OHZ</sub>	$\overline{CE}=V_{IL}$	0	25	ns
Output hold time	T <sub>OH</sub>	$\overline{CE}=\overline{OE}=V_{IL}$	0	-	ns

NOTE.1 T<sub>PSET</sub> is defined as the end of either  $\overline{CE}$  falling edge or address transition in random access term until the first page address transition.

Measurement condition

Input signal level	0V/3V
Input timing reference level	0.8V/2.0V
Output load	100pF
Output timing reference level	0.8V/2.0V

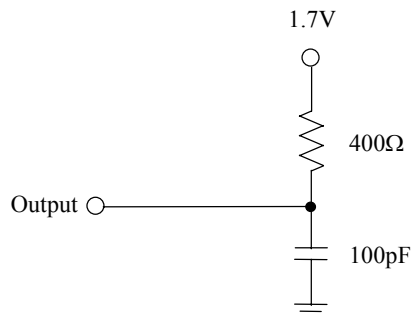

TIMING CHART

NORMAL MODE READ CYCLE

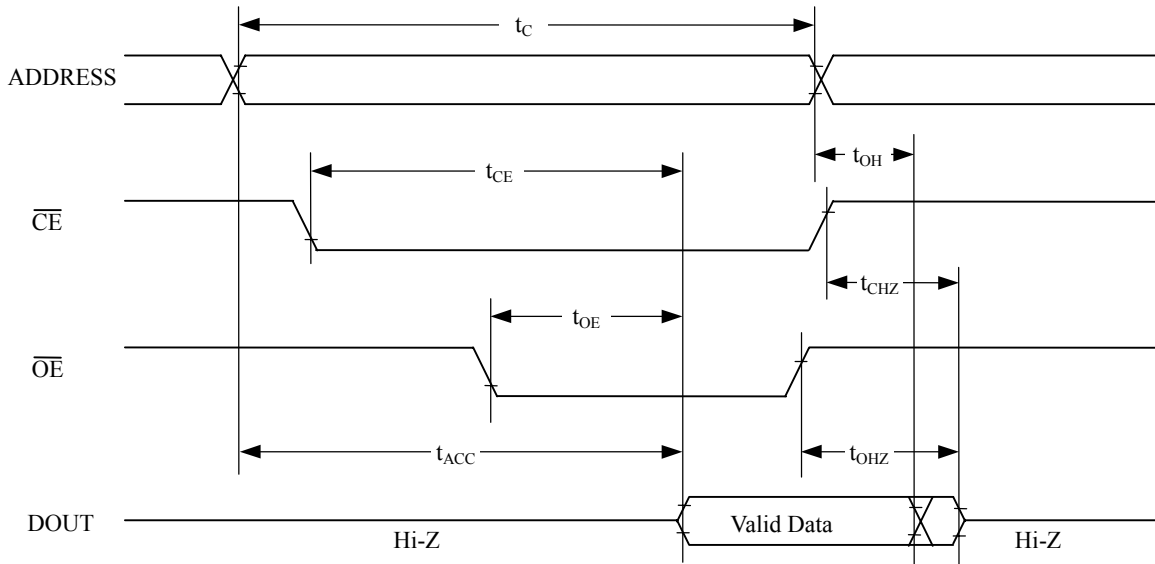

PAGE MODE READ CYCLE

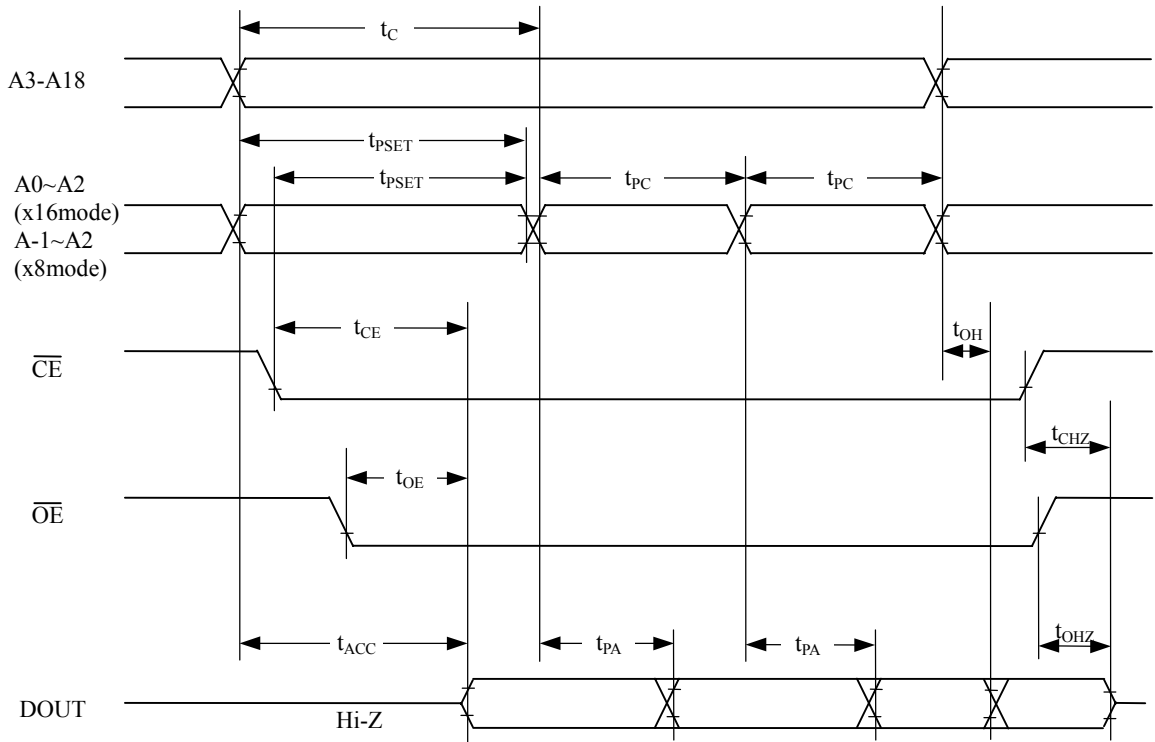

## **NOTICE**

The information contained herein can change without notice owing to product and/or technical improvements. Before using the product, please make sure that the information being referred to is up-to-date.

The outline of action and examples for application circuits described herein have been chosen as an explanation for the standard action and performance of the product. When planning to use the product, please ensure that the external conditions are reflected in the actual circuit, assembly, and program designs.

When designing your product, please use our product below the specified maximum ratings and within the specified operating ranges including, but not limited to, operating voltage, power dissipation, and operating temperature.

Oki assumes no responsibility or liability whatsoever for any failure or unusual or unexpected operation resulting from misuse, neglect, improper installation, repair, alteration or accident, improper handling, or unusual physical or electrical stress including, but not limited to, exposure to parameters beyond the specified maximum ratings or operation outside the specified operating range.

Neither indemnity against nor license of a third party's industrial and intellectual property right, etc. is granted by us in connection with the use of the product and/or the information and drawings contained herein. No responsibility is assumed by us for any infringement of a third party's right which may result from the use thereof.

The products listed in this document are intended for use in general electronics equipment for commercial applications (e.g., office automation, communication equipment, measurement equipment, consumer electronics, etc.). These products are not authorized for use in any system or application that requires special or enhanced quality and reliability characteristics nor in any system or application where the failure of such system or application may result in the loss or damage of property, or death or injury to humans. Such applications include, but are not limited to, traffic and automotive equipment, safety devices, aerospace equipment, nuclear power control, medical equipment, and life-support systems.

Certain products in this document may need government approval before they can be exported to particular countries. The purchaser assumes the responsibility of determining the legality of export of these products and will take appropriate and necessary steps at their own expense for these.

No part of the contents contained herein may be reprinted or reproduced without our prior permission.

All brand, company and product names are the trademarks or registered trademarks of their respective owners.

Copyright 1998 Oki Electric Industry Co., Ltd.  
Marketing Communications Team (RB)

# OKI

People To People Technology

## ADDRESSES & SEMICONDUCTOR WEB SITES

### **OKI Electric Industry Co., Ltd.,**

Device Business Group,  
10-3, Shibaura, 4-chome,  
Minato-ku, Tokyo 108, Japan,  
Tel.: +81-(0)3-5445-6327,  
Fax.: +81-(0)3-5445-6328,  
<http://www.oki.co.jp/semi/>

### **OKI Semiconductor Group,**

785 North Mary Avenue,  
Sunnyvale, CA 94086, U.S.A.,  
Tel.: +1-408-720-1900,  
Fax.: +1-408-720-1918,  
<http://www.okisemi.com/>

### **OKI Electric Europe GmbH,**

Head Office Europe,  
Hellersbergstrasse 2,  
D-41460 Neuss, Germany,  
Tel: +49-2131-15960,  
Fax: +49-2131-103539,  
<http://www.oki-europe.de/>

### **OKI Electronics (Hong Kong) Ltd.,**

Suite 1901-1&19, Tower 3,  
China Hong Kong City,  
33 Canton Road, Tsimshatsui,  
Kowloon, Hong Kong,  
Tel.: +852-2-736-2336,  
Fax.: +852-2-736-2395

### **OKI Semiconductor (Asia) Pte. Ltd.,**

78 Shenton Way 09-01,  
Singapore 0207,  
Tel.: +65-221-3722,  
Fax.: +65-323-5376

### **OKI Semiconductor (Asia) Pte. Ltd.,**

Taipei Branch,  
7th Fl. No.260, Tun Hwa North Road,  
Taipei, Taiwan, R.O.C.,  
Sumitomo-Flysun Building,  
Tel.: +886-2-2719-2561,  
Fax.: +886-2-2715-2892  
<http://www.oki.net.tw/>

*For further information, please contact:*