



### M1E2G4BPFi35

#### Quad Port Fiber Gigabit Ethernet Express Module Bypass Server Adapter

##### Product Description

Silicom's Quad Port fiber Gigabit Ethernet Express Module Bypass server adapter is a PCI-Express X4 network interface card that contains four Gigabit Ethernet ports on a PCI-E adapter.



The Silicom's Quad Port fiber Gigabit Ethernet Express Module Bypass server adapter is targeted to inline network system that maintains network connectivity when system fails.

Silicom's Quad Port Fiber Gigabit Ethernet Express Module Bypass server adapter supports Normal, Bypass and Disconnect modes. In Normal mode, the ports are independent interfaces.

In Bypass mode, all packets received from one port are transmitted to the adjacent port. In Disconnect mode, the adapter simulates switch / route cable disconnection.

Silicom's Quad Port Fiber Gigabit Ethernet Express Module Bypass server adapter can Bypass or disconnect its Ethernet ports on a host system failure, power off, or upon software request.

In Bypass mode, the connections of the Ethernet ports are disconnected from the system and switched over to the other port to create a crossed connection loop-back between the Ethernet ports. Hence, in bypass mode all packets received from one port are transmitted to the adjacent port and vice versa. This feature enables to bypass a failed system and provides maximum up time for the network.

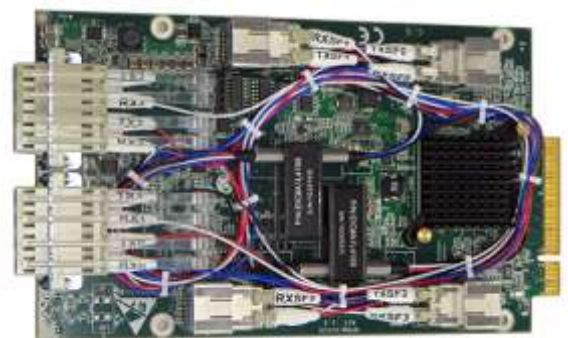

In Disconnect mode, the adapter simulates switch / router cable disconnection. In Disconnect mode, the switch / router does not detect link partner of the adapter.

Silicom's Quad Port Fiber Gigabit Express Module Bypass server adapter includes an on board WDT (Watch Dog Timer) controller.

The adapter's software drivers or software application can write commands to the on board WDT controller. The adapter's software drivers, WDT controller and the Bypass circuitry provide an interface that control and manage the mode of the adapter.

Silicom's Quad Port Fiber Gigabit Ethernet Express Module Bypass server adapter is based on Intel i350 Quad Port Gigabit Ethernet MAC+PHY of Intel Controller.

## Key Features

### Bypass / Disconnect:

- Bypass / Disconnect Ethernet ports on Power Fail, System Hangs or Software Application Hangs
- Software programmable Bypass, Disconnect or Normal Mode
- On Board Watch Dog Timer (WDT) Controller
- Software programmable time out interval
- Software Programmable WDT Enable / Disable counter
- Software programmable Bypass Capability Enable / Disable
- Software Programmable Disconnect Capability Enable / Disable
- Software Programmable mode (Bypass, Normal or Disconnect mode) at Power up
- Software Programmable mode (Bypass, Normal mode) at Power off
- Independent Bypass operation in every two ports
- Emulates standard NIC

### Performance Features:

- 8 Transmit and Receive queues per port
- Support for 8 pools (single queue) of virtual machine Device Queues (VMDq) per port
- Support Direct Cache Access (DCA)
- Support Intel I/O Acceleration Technology v3.0
- TSO interleaving for reduced latency
- Minimized device I/O interrupts using MSI and MSI-X
- UDP, TCP and IP checksum offload
- UDP and TCP transmit segmentation offload (TSO)
- SCTP receive and transmit checksum offload

### Common Key features:

- PCI Express ExpressModule Electromechanical Specification Revision 1.0
- Support PCI Express Base Specification 2.1 (5GT/sec)
- High performance, reliability, and low power use in Intel i350 quad integrated MAC + PHY and SERDES chip controller
- Hardware acceleration that can offload tasks from the host processor. The controllers can offload TCP/UDP/IP checksum calculations and TCP segmentation
- Server class reliability, availability and performance features:
- Link Aggregation and Load Balancing
- Switch dependent: 802.3ad (LACP), Generic Trunking ( GEC / FEC)
- Switch and NIC Independent

- Failover
- Priority queuing – 802.1p layer 2 priority encoding
- Virtual LANs –802.1q VLAN tagging
- Jumbo Frame (9.5KB)
- 802.x flow control
- Multicast/ broadcast Packet replication
- Statistics for SNMP MIB II, Ethernet like MIB, and Ethernet MIB (802.3z, Clause 30)
- Supports Vital Product Data (VPD)
- Supports End to End CRC (ECRC)
- Supports Latency Tolerance Reporting (LTR)
- Minimized device I/O interrupts using MSI and MSI-X
- Supports IEEE 1588
- LEDs indicators for link/Activity/Bypass/ Disconnect Mode status
- Hot Plug not supported. Can be supported by assembly change

#### Fiber Gigabit Ethernet 1000Base-SX:

- Independently Fiber Gigabit Ethernet channel/s support Gigabit Ethernet 1000Base-SX
- Small Form Factor (SFF) LC Connectors

#### Fiber Gigabit Ethernet 1000Base-LX:

- Independently Fiber Gigabit Ethernet channel/s support Gigabit Ethernet 1000Base-LX
- Small Form Factor (SFF) LC Connectors

### Technical Specifications

Bypass Specifications	
<b>WDT Interval (Software Programmable):</b>	3,276,800 mSec (3,276.8 Sec): Maximum 100 mSec ( 0.1 Sec) : Minimum WDT Interval = (2^wdt_interval_parameter)*(0.1) sec. wdt_interval_parameter: { Valid Range: 0-15}
Fiber Gigabit Ethernet Technical Specifications – (1000Base-SX) Adapters:	
<b>IEEE Standard / Network topology:</b>	Fiber Gigabit Ethernet, 1000Base-SX (850nm)
<b>Data Transfer Rate:</b>	2000Mbit/s in full duplex mode per port
<b>Cables and Operating</b>	Multimode fiber:

<b>distance:</b>	137m maximum at 62.5 um ** ** Theoretical Distance – Defined as half a distance as stated by the IEEE 802.3 standard
<b>Output Transmit Power:</b>	Normal Mode (Bypass Off): Minimum: -9.5 dBm
<b>Optical Receive Sensitivity:</b>	Normal Mode (Bypass Off) Maximum: -17 dBm
<b>Insertion Loss:</b>	Bypass Mode: Insertion loss (Optical Power attenuation between TX to RX) Maximum 1.6 dB
<b>Fiber Gigabit Ethernet Technical Specifications – (1000Base-LX) Adapters:</b>	
<b>IEEE Standard / Network topology:</b>	Fiber Gigabit Ethernet, 1000Base- LX (1310nM)
<b>Data Transfer Rate:</b>	2000Mbit/s in full duplex mode per port
<b>Cables and Operating distance:</b>	Single-Mode: 5000m at 9um ** Theoretical Distance – Defined as half a distance as stated by the IEEE 802.3 standard
<b>Output Transmit Power:</b>	Normal Mode ( Bypass Off): Minimum: -10.8 dBm (-9.5-0.3-1)
<b>Optical Receive Sensitivity:</b>	Normal Mode (Bypass Off) Maximum: -19 dBm
<b>Insertion Loss:</b>	Bypass Mode: Insertion loss (Optical Power attenuation between TX to RX) Maximum 1.6 dB
<b>Operating Systems Support</b>	
<b>Operating system support:</b>	Linux Windows FreeBSD Vmware
<b>General Technical Specifications</b>	
<b>Interface Standard:</b>	PCI ExpressModule Specification revision 1.0

	PCI-Express Base Specification Revision 2.1 (5 GTs)
<b>Board Size:</b>	168.2mm x 98mm (6.62"X3.858")
<b>PCI Express Card Type:</b>	X4
<b>PCI Express Voltage:</b>	+12V ± 15%
<b>PCI Connector:</b>	Gold Finger: X8
<b>Controller:</b>	Intel i350AM4
<b>Holder:</b>	Not included
<b>I/O:</b>	LC located on internal bracket
<b>Weight:</b>	190g (6.702 Oz)
<b>Operating Temperature:</b>	0°C – 50°C (32°F – 122°F)
<b>Storage Temperature:</b>	-20°C–65°C (-4°F–149°F)
<b>EMC Certifications:</b>	<p>FCC Part 15, Subpart B Class B</p> <p>Conducted Emissions</p> <p>Radiated Emissions</p> <p>CE EN 55022: 1998 Class B Amendments A1: 2000; A2: 2003</p> <p>Conducted Emissions</p> <p>Radiated Emissions</p> <p>CE EN 55024: 1998 Amendments A1: 2000; A2: 2003</p> <p>Immunity for ITE Amendment A1: 2001</p> <p>CE EN 61000-3-2 2000, Class A</p> <p>Harmonic Current Emissions</p> <p>CE EN 61000 3-3 1995, Amendment A1: 2001</p> <p>Voltage Fluctuations and Flicker</p> <p>CE IEC 6100-4-2: 1995</p> <p>ESD Air Discharge 8kV. Contact Discharge 4kV.</p> <p>CE IEC 6100-4-3:1995</p> <p>Radiated Immunity (80-1000Mhz), 3V/m 80% A.M. by 1kHz</p> <p>CE IEC 6100-4-4:1995</p> <p>EFT/B: Immunity to electrical fast transients 1kV Power</p> <p>Leads, 0.5Kv Signals Leads</p> <p>CE IEC 6100-4-5:1995</p> <p>Immunity to conductive surges COM Mode; 2kV,</p> <p>Dif. Mode 1kV</p>

	<p>CE IEC 6100-4-6:1996          Conducted immunity (0.15-80 MHz) 3VRMS 80% A.M          By 1kHz          CE IEC 6100-4-11:1994          Voltage Dips and Short Interruptions          V reduc &gt;95%, 30% &gt;95% Duration 0.5per, 25per, 250per</p>
<b>LEDs</b>	
<b>LEDs:</b>	<p>(2) LEDs per port          Left LED: Link/Act :          Turns on link (Green),          Blinks on activity (Green)          Right LED : Link Speed / Bypass / Disconnect :          Turns on Yellow 1G Link.          Blink Yellow on Disconnect          Blink Green on Bypass</p>
<b>LEDs location:</b>	<p>LEDs are located on the PCB, visible via holes in the metal bracket. Each 2 green act/ link and speed link/bypass/disconnect LEDs are located above their own LC connector port- visible by light pipes</p>
<b>Connectors:</b>	<p>(4) LC</p>

**Functional Description**

Silicom’s Quad Port Fiber Bypass adapter supports Normal, Bypass and Disconnect modes. In Normal mode, the ports are independent interfaces (see Figure 1: Normal mode, one Bypass pair is illustrated).

**Figure 1: Normal Mode Functional Block Diagram**

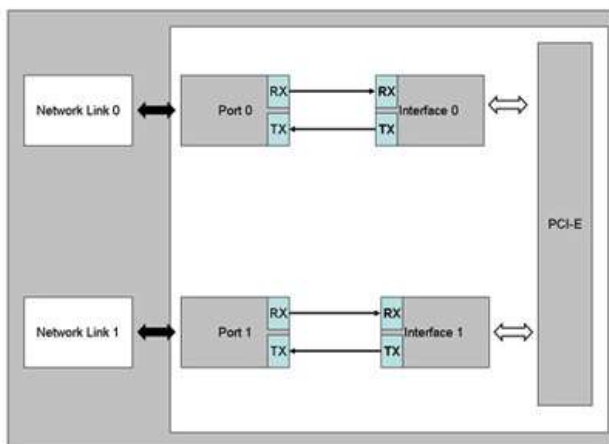

In Bypass mode, the connections of the Ethernet network ports are disconnected from the interfaces and switched over to the other port to create a crossed connection loop-back between the Ethernet ports. The connections of the interfaces are left unconnected. (See Figure 2: one Bypass pair illustrated)

**Figure 2: Bypass Mode Functional Block Diagram**

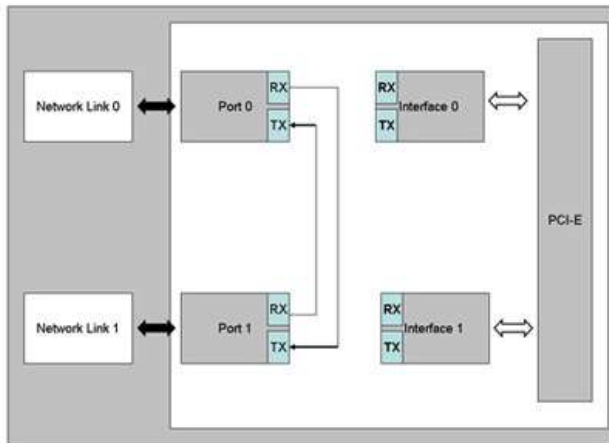

In Disconnect mode, the transmit connections of the Ethernet network ports are disconnected from the interfaces. (See Figure 3: one Bypass pair illustrated)

**Figure 3: Disconnect Mode Functional Block Diagram**

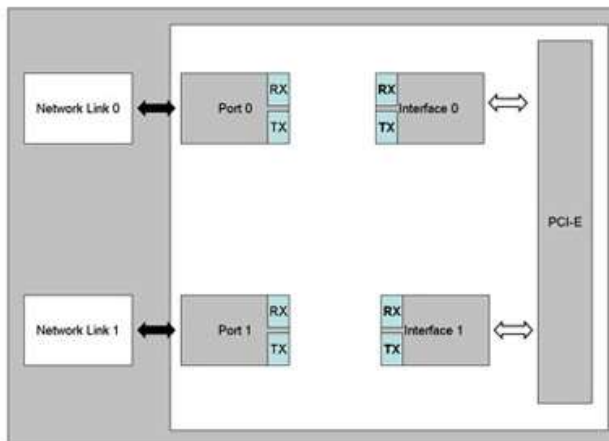

Silicom's Quad Port Fiber Gigabit Ethernet Bypass server adapter supports software programmable to select Normal, Bypass or Disconnect modes.

Silicom's Quad Port Fiber Gigabit Ethernet supports Disable Bypass, Disable Disconnected capabilities; hence, if those adapters receive Disable Bypass capability / Disable Disconnect commands, the adapter does not Bypass / does not Disconnect its Ethernet ports, The Disable Bypass Capabilities are reserved also after power off. This feature enables to emulate a standard NIC.

Silicom's Quad Port Fiber Gigabit Ethernet supports Disable supports setting the default mode at power up and power off. Those setting are reserved also after power off.

## Order Information

P/N	Description	Notes
<b>M1E2G4BPFI35-SD</b>	Quad Port Fiber (SX) Gigabit Ethernet ExpressModule Bypass Server Adapter	RoHS Compliant, X8, based on Intel I350AM4, PCI-E 2.0 Express Module , Bypass w/ Disconnect short, PCI-E SIOM
<b>M1E2G4BPFI35-LX-SD</b>	Quad Port Fiber (LX) Gigabit Ethernet ExpressModule Bypass Server Adapter	RoHS Compliant, X8, based on Intel I350AM4, PCI-E 2.0 Express Module , Bypass w/ Disconnect short, PCI-E SIOM

-SD: Side Driver

RoHS Compliant / Lead free adapter

**1V0**