

---

## Universal High Voltage Single Channel LED Driver

### 1. Functional Description of the AMG-LL9910B

---

The AMG-LL9910B is a universal high voltage LED driver IC. Both buck and boost topologies are possible. It has one current regulated channel.

The AMG-LL9910B controls an external MOSFET at fixed switching frequencies up to 300 kHz. The frequency can be programmed by using a single resistor. The LED string is driven at a constant current rather than a constant voltage, thus providing constant light output and enhanced reliability. The output current to a LED string can be programmed to any value between 0 and 100% by applying an external control voltage at the linear dimming control input. The IC provides a low-frequency PWM dimming input that can accept an external control signal with a duty ratio between 0% and 100% and a frequency of up to a few kilohertz.

### 2. Features

---

- Supply voltage 8VDC ... 450VDC
- >90 % efficiency
- 8 – 450V input voltage
- Peak current mode converter
- Linear and PWM dimming capability
- Buck and Boost topology
- Pin compatible with other HV LED drivers
- SOP8 Package with exposed pad for a lower thermal resistance

### 3. Application

---

The AMG-LL9910B is suitable for:

- DC/DC or AC/DC LED driver applications
- LED backlighting
- General-purpose LED lighting
- General-purpose constant current source
- Battery chargers

## Universal High Voltage Single Channel LED Driver

### 3.1. Example Application Drawing

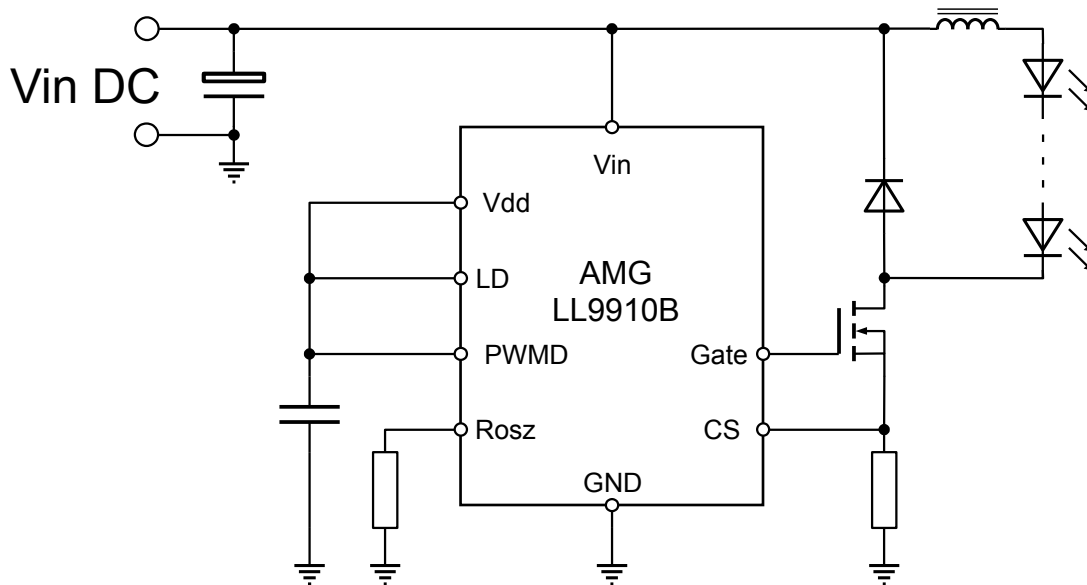

Figure 1: Buck LED Driver

---

## Universal High Voltage Single Channel LED Driver

---

### Table of Contents

---

1.Functional Description of the AMG-LL9910B.....	1
2.Features.....	1
3.Application.....	1
3.1.Example Application Drawing.....	2
4.Block Diagram.....	4
5.Block Descriptions.....	4
6.Pinning.....	5
7.Absolute Maximum Ratings.....	6
8.Electrical Characteristics.....	6
8.1.Operational Range.....	6
8.2.DC Characteristics.....	7
8.3.AC Characteristics.....	7
9.Application.....	8
9.1.Example Application Circuit.....	8
9.2.Application Notes.....	8
9.3.Off Line LED Driver.....	11
9.4.Off Line LED Driver with Digital I/F.....	11
9.5.Off Line LED Driver with Temp-Protection.....	12
9.6.Battery Powered LED Driver.....	12
10.Ordering Information.....	13
11.IC-Package.....	13
12.IC-Marking.....	13
13.Notes and Cautions.....	14
13.1.ESD Protection.....	14
13.2.Storage conditions.....	14
14.Disclaimer.....	14
15.Contact Information.....	15

## Universal High Voltage Single Channel LED Driver

### 4. Block Diagram

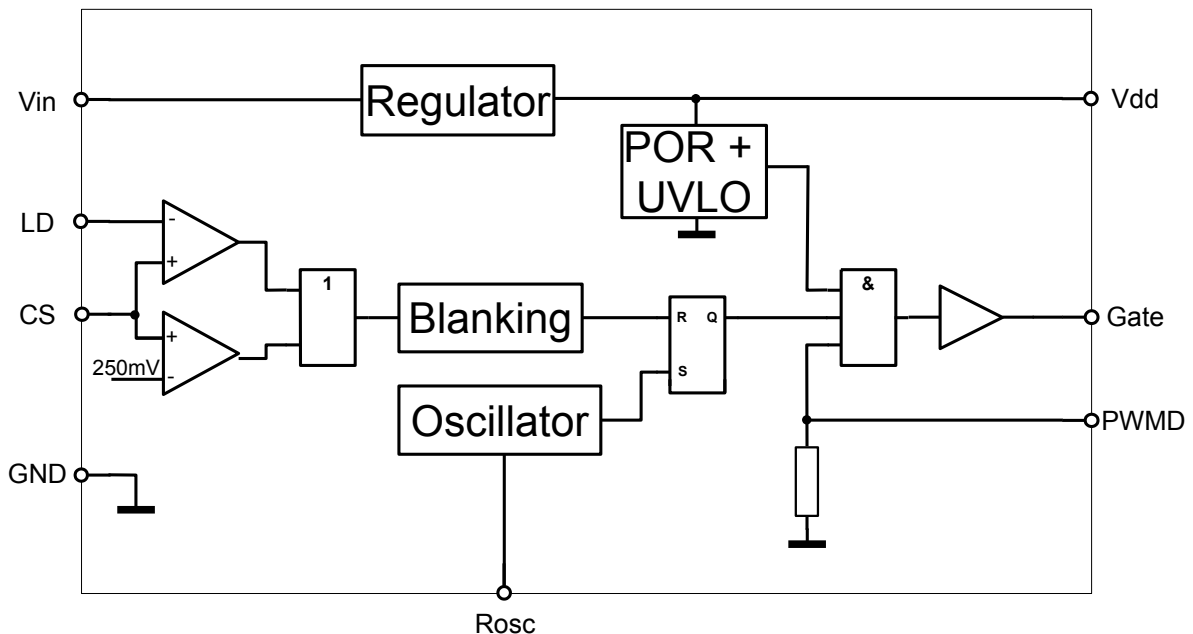

Figure 2: Block Diagram

### 5. Block Descriptions

#### Linear Regulator

Generates a stable supply for the logic. May also supply external circuitry.

#### POR + UVLO

Power on Reset and Under Voltage lockout. The IC is released from reset, after the Vdd rises above the UVLO voltage.

#### Linear Dimming Comparator

Manual setting of the  $V_{CS}$  threshold.

#### Current Sense Comparator

Current limiting comparator.

#### Blanking Timer

Inserts a time delay from CS trip to Gate low, in order to enable 100% duty cycle.

## Universal High Voltage Single Channel LED Driver

### RS Flip Flop

Enables and disables the gate driver. Set by the oscillator, reset by current limit.

### Gate Driver

Drives external MOSFET. Gated by external PWM or enable signal.

### Oscillator

Determines PWM frequency.

## 6. Pinning

PIN#	Symbol	Description
1	Vin	Supply input
2	CS	Current Sense
3	GND	Ground
4	Gate	Driver output for external MOSFET
5	PWMD	PMW dimming input
6	Vdd	Linear regulator output
7	LD	Linear Dimming
8	Rosc	Resistor to GND setting Oscillator Frequency
EP	-	Thermal conductive pad on the bottom. Connect this pad to Ground, and provide sufficient thermal coupling to remove heat from the package.

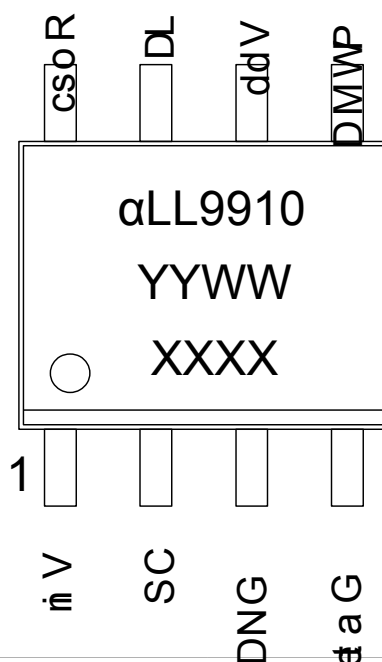

## Universal High Voltage Single Channel LED Driver

### 7. Absolute Maximum Ratings

The Absolute Maximum Ratings may not be exceeded under any circumstances.

#	Symbol	Parameter	Min	Max	Unit
1	V <sub>in</sub>	Supply input voltage	-0.5	470	V
2	V <sub>logic</sub>	Voltage on CS, LD, PWMD, Gate	-0.3	V <sub>dd</sub> + 0.3	V
3	T <sub>j</sub>	Junction temperature		150	°C
4	T <sub>s</sub>	Storage temperature	-65	150	°C
5	V <sub>ddmax</sub>	Max. voltage at V <sub>dd</sub>	-0.3	12	V
6	R <sub>thja</sub>	Thermal resistance junction ambient		42	K/W
7	P <sub>tot@25°C</sub>	Total power dissipation		2.5	W

Note: All voltages are with respect to GND

### 8. Electrical Characteristics

#### 8.1. Operational Range

(T<sub>a</sub>=25°C unless noted otherwise)

#	Symbol	Parameter	Min	Max	Unit
1	V <sub>in</sub> <sup>1)</sup>	Supply input voltage	10	450	V
2	T <sub>a</sub>	Operating ambient temperature	-40	125 <sup>1) 2)</sup>	°C
3	PWM	Duty Cycle		100	%

Note: <sup>1)</sup> Also limited by maximum power dissipation, whichever is lower.

$$^2)R_{thja} = (T_j - T_a) / P_{tot}$$

## Universal High Voltage Single Channel LED Driver

### 8.2. DC Characteristics

(Ta=25°C unless noted otherwise)

#	Symbol	Parameter	Min	Typ	Max	Unit
1	V <sub>dd</sub>	Regulator output voltage	7.25	7.5	7.75	V
2	I <sub>ext</sub> <sup>3)</sup>	Current for ext. circuitry (10V < V <sub>in</sub> < 100V)			0.7	mA
3	UVLO	Undervoltage lockout (V <sub>dd</sub> rising)	6.45	6.7	6.95	V
4	ΔUVLO	Undervoltage lockout hysteresis (V <sub>dd</sub> falling)		500		mV
5	V <sub>in low</sub>	Input voltage logic low (PWMD)			0.8	V
6	V <sub>in high</sub>	Input voltage logic high (PWMD)	2			V
7	R <sub>PWMD</sub>	Pull down on PWMD pin	50	100	150	kΩ
8	V <sub>cs</sub>	Current sense threshold	225	250	275	mV
10	V <sub>gate low</sub>	Gate driver low output voltage (@10mA)	0		0.3	V
11	V <sub>gate high</sub>	Gate driver high output voltage (@-10mA)	V <sub>dd</sub> -0.3		V <sub>dd</sub>	V
12	I <sub>dd</sub>	Current consumption (shutdown), V <sub>PWM</sub> =0V		0.5	1	mA

Note: <sup>3)</sup> Also limited by maximum power dissipation, whichever is lower.

### 8.3. AC Characteristics

(Ta=25°C unless noted otherwise)

#	Symbol	Parameter	Min	Typ	Max	Unit
1	f <sub>osc</sub>	Oscillator frequency @ R <sub>osc</sub> =1000kOhm	20	25	30	kHz
		Oscillator frequency @ R <sub>osc</sub> =226kOhm	80	100	120	kHz
2	t <sub>blank</sub>	Minimal gate on time (Current sense blanking time)	150	215	280	ns
3	t <sub>delay</sub>	Time from CS trip to Gate low		80	150	ns
4	t <sub>rise</sub>	Gate driver output rise time (C <sub>gate</sub> = 500pF)		30	50	ns
5	t <sub>fall</sub>	Gate driver output fall time (C <sub>gate</sub> = 500pF)		30	50	ns

## Universal High Voltage Single Channel LED Driver

### 9. Application

#### 9.1. Example Application Circuit

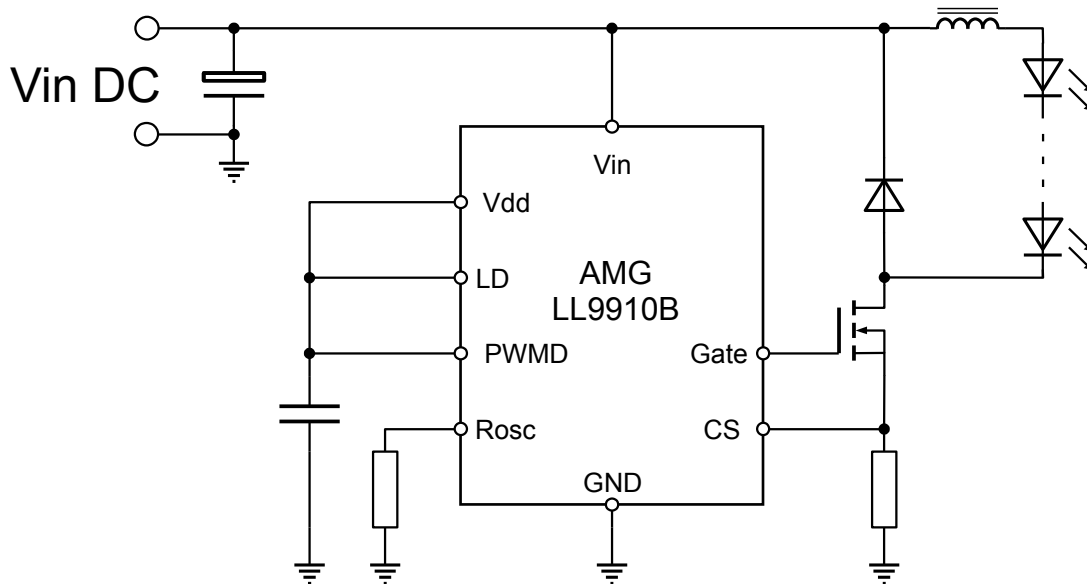

Figure 3: Buck LED Driver

#### 9.2. Application Notes

##### a) Peak Current Regulation

The oscillator resistor sets the PWM frequency. After each oscillator period, the gate driver is pulled high and the duty cycle begins.

When the current over sense resistor  $R_{CS}$  reaches the current limit, the current sense comparator will trip and after blanking time the gate driver output is pulled low and the duty cycle ends.

Smaller inductors and lower PWM frequencies will provide for higher current ripple. In the case that the highest light intensity is desired, the ripple should be maximized and the LED driven to its specified peak current limit.

In the case that the highest efficacy and longest LED lifetime is desired, the LED needs to be driven to the optimum current value only. In this situation, the ripple should be kept as low as possible. Bigger inductor values and higher PWM frequencies will help achieve this result.



---

## Universal High Voltage Single Channel LED Driver

### b) LED Current

The maximum LED current is programmed with an external resistor  $R_{CS}$ .

If peak current for highest light intensity is desired, the resistor value should be calculated as follows:

$$R_{CS} = 250\text{mV}/I_{LED\ peak}$$

If an average current for highest efficacy and longest lifetime is desired, the resistor value should be calculated as follows:

$$R_{CS} = 250\text{mV}/[I_{LED\ avg} + (0.5*\Delta I_L)]$$

$$\Delta I_L = I_{ripple}$$

### c) Inductor Value

The inductor value depends on the input voltage, output voltage, PWM frequency and the desired current ripple.

First, we calculate the ratio between input and output voltage and the voltage over the inductor. The input voltage is the average supply voltage for the IC while the output voltage is the number of LEDs on the string times the LED forward voltage.

$$V_{out} = n * V_F$$

$$V_L = V_{in} - V_{out}$$

**Please note:** that the forward LED voltage is a function of the LED current. The LED data sheet should provide the corresponding forward voltage for a given LED current.

$$D = V_{out}/V_{in}$$

For a buck design, D must be lower than 1.

Then, the ripple of the LED currents needs to be determined, which will then provide the actual inductor value.

For the maximum peak current (highest intensity), a current ripple higher than 50% (0.5) is desirable.

$$\Delta I_L = \text{ripple} * I_{LED\ peak}$$

Inductor values should be rounded down in this case.

For a stable average current (highest efficacy), a current ripple lower than 20% (0.2) is desirable.

$$\Delta I_L = \text{ripple} * I_{LED\ avg}$$

Inductor values should be rounded up for this case.

$$L = (D/f_{osc}) * (V_L/\Delta I_L)$$

---

## Universal High Voltage Single Channel LED Driver

### d) Linear Dimming

If the second comparator is provided with a threshold voltage lower than the internal threshold voltage of the first comparator, the current over the LED can be manually adjusted. This can be achieved with any analog voltage between 0 and the internal reference voltage (e.g. with a potentiometer).

### e) Digital Dimming

With an external PWM signal at the PWMD pin, the gate driver can be gated. This means, the LED will light up during the duty cycle of the external PWM signal and vice versa, the LED will be off during the off-time of the external PWM signal.

The external PWM frequency needs to be much smaller than the frequency of the AMG-LL9910B. The external PWM frequency should be at least 10x smaller, otherwise fluctuation effects may occur.

The PWMD pin may also be used to enable or disable the device. The IC is enabled, when PWMD is pulled to Vcc. It is disabled, when PWMD is pulled to GND:

### f) PWM Frequency

$$F_{\text{PWM}} [\text{kHz}] = 25000 / (R_{\text{osc}} [\text{k}\Omega] + 22)$$

### g) PFC

The AMG-LL9910B does not have a PFC integrated stage. As such, a PFC is usually necessary for off line LED drivers. This can be either a passive PFC or even an active one, when the power increases relatively high.

**Universal High Voltage Single Channel LED Driver**

9.3. Off Line LED Driver

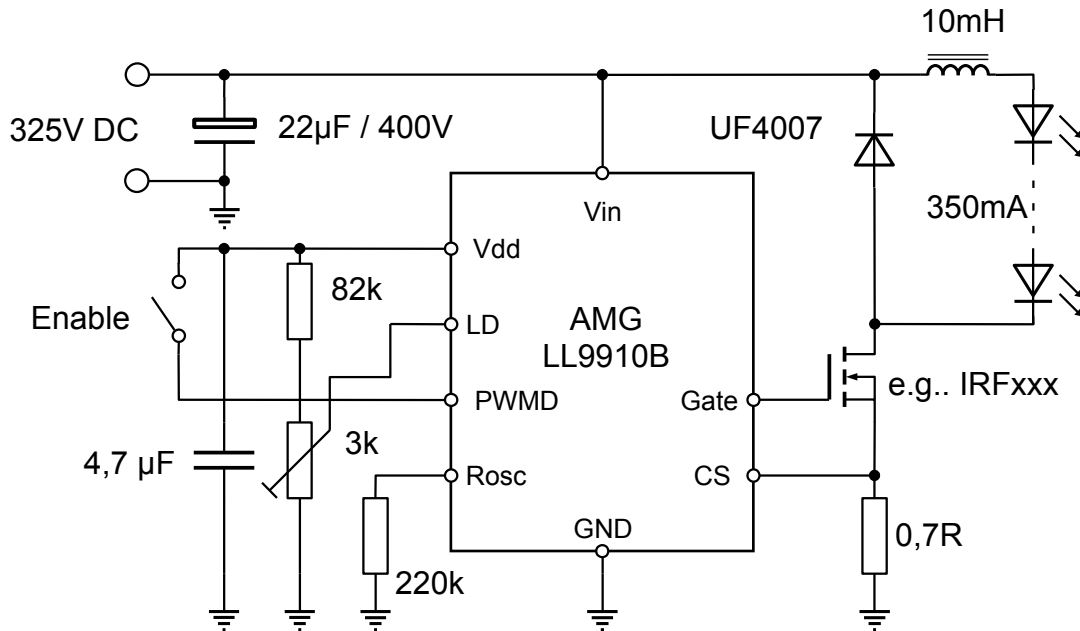

Figure4: Buck topology, linear dimming, enable switch

9.4. Off Line LED Driver with Digital I/F

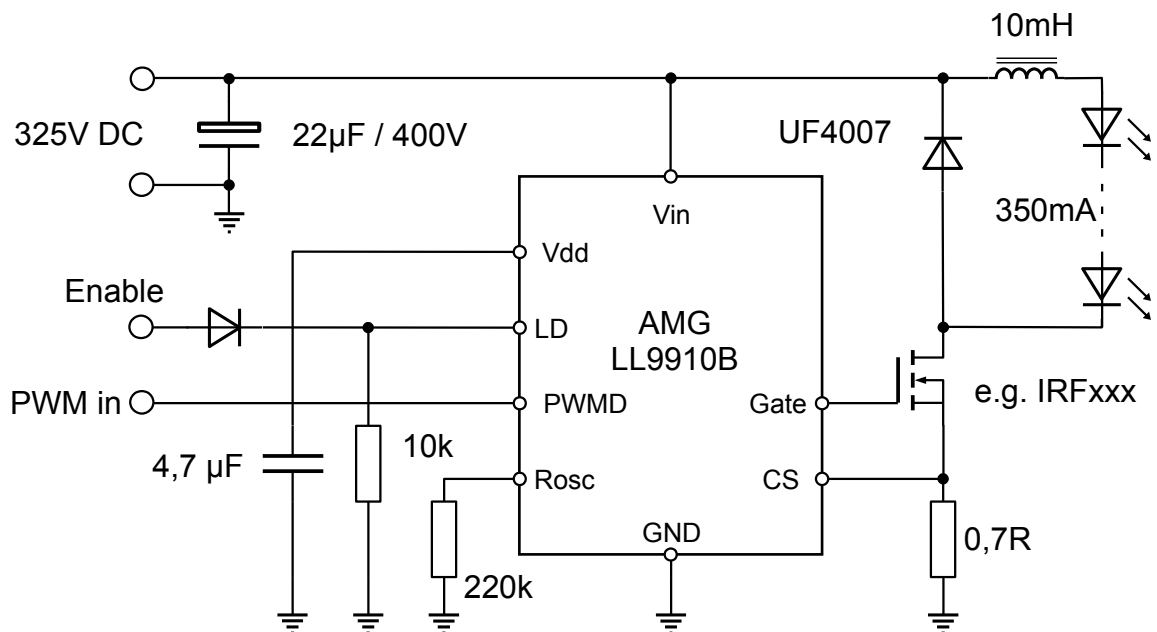

Figure 5: Buck topology, digital dimming, enable signal

**Universal High Voltage Single Channel LED Driver**

9.5. Off Line LED Driver with Temp-Protection

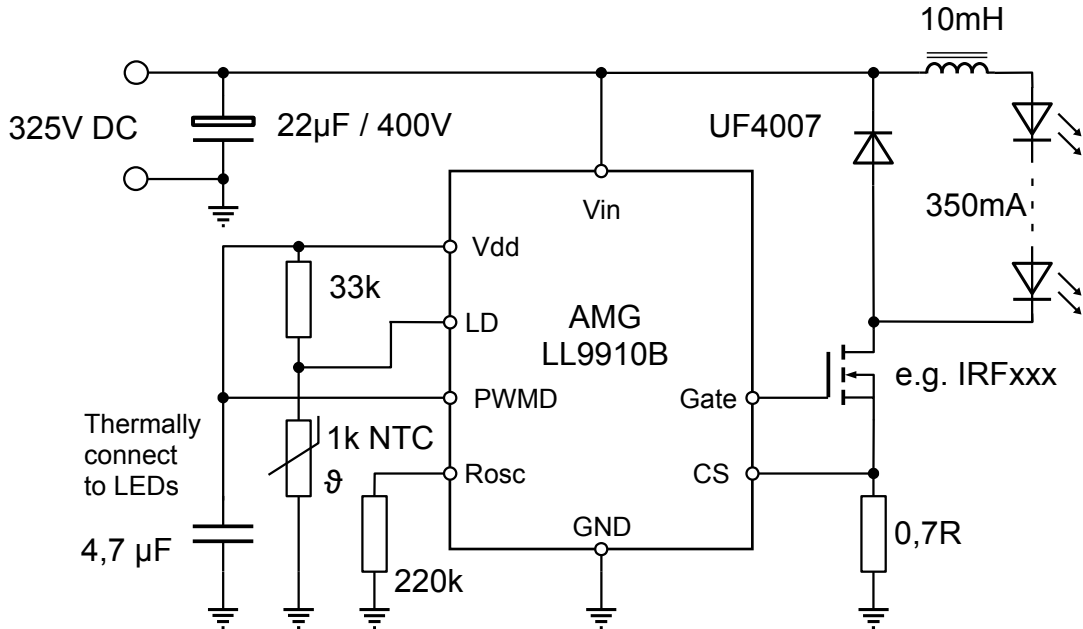

Figure 6: Buck topology, with Temp-Protection

9.6. Battery Powered LED Driver

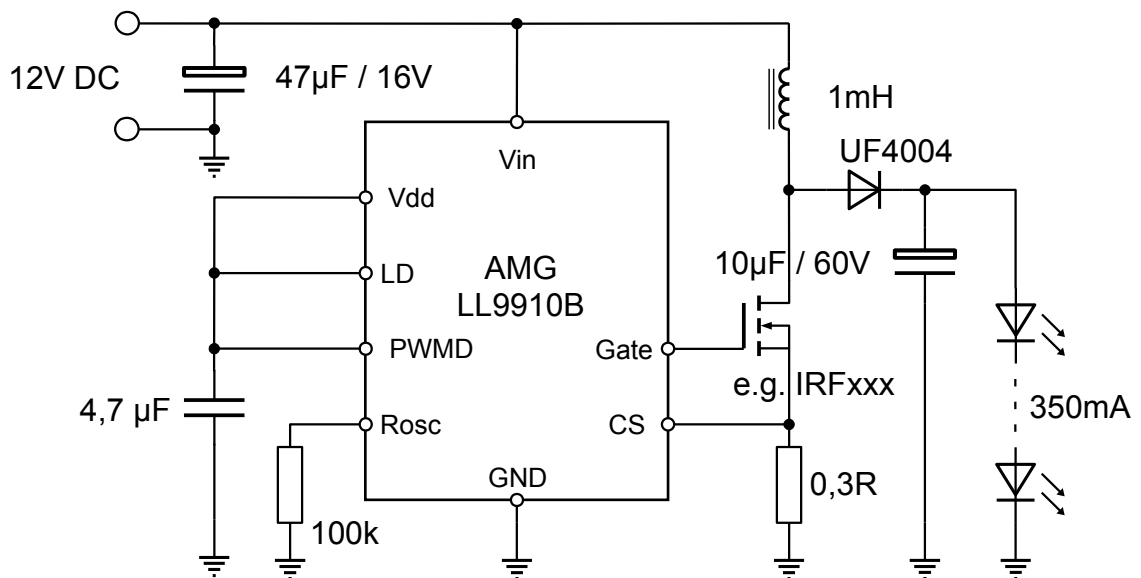

Figure 7: Boost topology

**Universal High Voltage Single Channel LED Driver**

**10. Ordering Information**

AMG-LL9910B-ISO08U

SOP8 in tubes

AMG-LL9910B-ISO08R

SOP8 in tape and reel

**11. IC-Package**

SOP8 with exposed pad

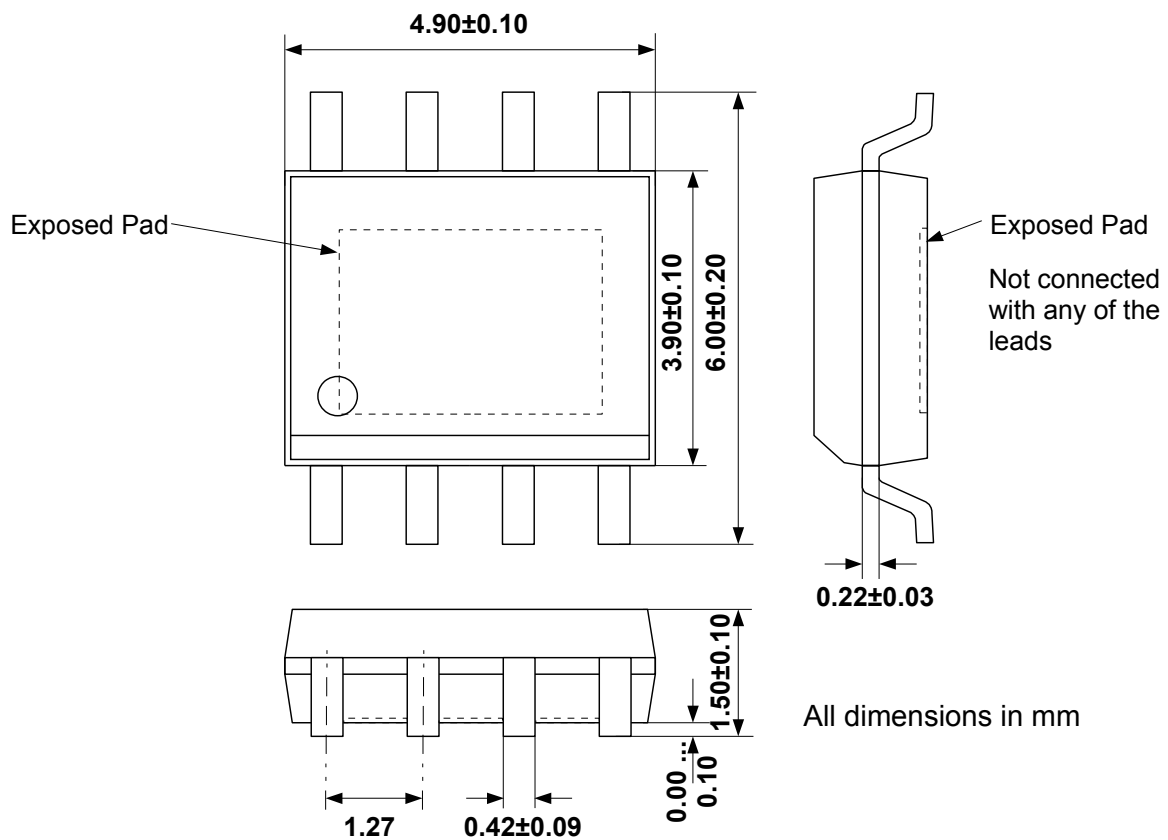

**12. IC-Marking**

$\alpha$ LL9910

4 digit date code

4 ... 6 digit lot code

---

## Universal High Voltage Single Channel LED Driver

### 13. Notes and Cautions

---

#### 13.1. ESD Protection

---

The Requirements for Handling Electrostatic Discharge Sensitive Devices are described in the JEDEC standard JESD625-A. Please note the following recommendations:

- When handling the device, operators must be grounded by wearing a grounded wrist strap with at least 1M $\Omega$  resistance with direct skin contact.
- Operators must at all times, wear ESD protective shoes or the area should be surrounded by ESD protected floor mats.
- The opening of an ESD protective package or device must only occur on a properly equipped ESD workbench. The tape with which the package is held together must be cut with a sharp cutting tool, never pulled or ripped off.
- Any unnecessary contact with the device or any unprotected conductive points should be avoided.
- Only work with qualified and grounded tools, measuring equipment, casings and workbenches.
- When outside of properly protected ESD-areas, the device or any electronic assembly must be protected and always be transported in EGB/ESD shielded packaging.

#### 13.2. Storage conditions

---

The AMG-LL9910B corresponds to moisture sensitivity classification ML2, according to JEDEC standard J-STD-020, and should be handled and stored according to J-STD-033.

### 14. Disclaimer

---

Information given in this data sheet is believed to be accurate and reliable. However, no responsibility is assumed for the consequences of its use nor for any infringement of patents or other rights of third parties that may result from its use.

The values stated in Absolute Maximum Ratings may under no circumstances be exceeded. No warranty is given for use in life support systems or medical equipment without the specific written consent of alpha microelectronics gmbh. For questions regarding the application please contact the publisher.

The declared data are only a description of the product. They are not guaranteed properties as defined by law. Samples are provided without obligation and cannot give rise to any liability. Reprinting of this data sheet – or any part of it – is not allowed without the license of the publisher. Data sheets are subject to change without any notice.

## Universal High Voltage Single Channel LED Driver

---

### 15. Contact Information

---

This data sheet is published by alpha microelectronics gmbh. To order samples or inquire information please contact:

alpha microelectronics gmbh  
Im Technologiepark 1  
15236 Frankfurt (Oder)  
Germany

[am.info@alpha-microelectronics.de](mailto:am.info@alpha-microelectronics.de)  
[www.alpha-microelectronics.de](http://www.alpha-microelectronics.de)

+49-335-557-1750 (telephone)  
+49-335-557-1759 (fax)

© All rights reserved.

