

# DIFFERENTIAL PRESSURE (FLOW) TRANSMITTER

**DATA SHEET**

**FKC...4**

The FCX-AII differential pressure (flow) transmitter accurately measures differential pressure, liquid level, gauge pressure or flow rate and transmits a proportional 4 to 20mA signal. The transmitter utilizes a unique micromachined capacitance silicon sensor with state-of-the-art microprocessor technology to provide exceptional performance and functionality.



## FEATURES

1. **High accuracy ±0.07%**  
0.07% accuracy is a standard feature.  
Fuji's micro-capacitance silicon sensor assures this accuracy for all elevated or suppressed calibration ranges without additional adjustment.
2. **Minimum environmental influence**  
The "Advanced Floating Cell" design which protects the pressure sensor against changes in temperature, static pressure, and overpressure substantially reduces total measurement error in actual field applications.
3. **Fuji/HART® bilingual communications protocol and FOUNDATION™ fieldbus and Profibus™ compatibility**  
FCX-AII series transmitter offers bilingual communications to speak both Fuji proprietary protocol and HART®. Any HART® compatible devices can communicate with FCX-AII. Further, by upgrading electronics FOUNDATION™ fieldbus and Profibus™ are also available.
4. **Application flexibility**  
Various options that render the FCX-AII suitable for almost any process applications include.
  - Analog indicator at either the electronics side or terminal side
  - Full range of hazardous area approvals
  - Built-in RFI filter and lightning arrester
  - 5-digit LCD meter with engineering unit
  - Stainless steel electronics housing
  - Wide selection of materials
5. **Programmable output Linearization Function**  
In addition to Linear and Square Root, output signal can be freely programmable.  
(Up to 14 compensated points at approximation.)
6. **Burnout current flexibility (Under Scale: 3.2 to 3.8mA, Over Scale: 20.8 to 21.6mA)**  
Burnout signal level is adjustable using Model FXW Hand Held Communicator (HHC) to comply with NAMUR NE43.
7. **Dry calibration without reference pressure**  
Thanks to the best combination of unique construction of mechanical parts (Sensor unit) and high performance electronics circuit (Electronics unit), reliability of dry calibration without reference pressure is at equal level as wet calibration.

## SPECIFICATIONS

### Functional specifications

**Service:** Liquid, gas, or vapour  
**Static pressure, span, and range limit:**

Type	Static pressure [MPa] {bar}	Span limit [kPa] {m bar}		Range limit [kPa] {m bar}
		Min.	Max.	
FKC□11	-0.1 to + 3.2 {-1 to + 32}	0.1 { 1 }	1 { 10 }	+/- 1 { +/- 10 }
FKC□22	-0.1 to + 10 {-1 to + 100}	0.1 { 1 }	6 { 60 }	+/- 6 { +/- 60 }
FKC□23	-0.1 to + 10 {-1 to + 100}	0.32 { 3.2 }	32 { 320 }	+/- 32 { +/- 320 }
FKC□25	-0.1 to + 10 {-1 to + 100}	1.3 { 13 }	130 { 1300 }	+/- 130 { +/- 1300 }
FKC□26	-0.1 to + 10 {-1 to + 100}	5 { 50 }	500 { 5000 }	+/- 500 { +/- 5000 }
FKC□33	-0.1 to + 16 {-1 to + 160}	0.32 { 3.2 }	32 { 320 }	+/- 32 { +/- 320 }
FKC□35	-0.1 to + 16 {-1 to + 160}	1.3 { 13 }	130 { 1300 }	+/- 130 { +/- 1300 }
FKC□36	-0.1 to + 16 {-1 to + 160}	5 { 50 }	500 { 5000 }	+/- 500 { +/- 5000 }
FKC□38	-0.1 to + 16 {-1 to + 160}	30 { 300 }	3000 { 30000 }	+/- 3000 { +/- 30000 }
FKC□43	-0.1 to + 42 {-1 to + 420}	0.32 { 3.2 }	32 { 320 }	+/- 32 { +/- 320 }
FKC□45	-0.1 to + 42 {-1 to + 420}	1.3 { 13 }	130 { 1300 }	+/- 130 { +/- 1300 }
FKC□46	-0.1 to + 42 {-1 to + 420}	5 { 50 }	500 { 5000 }	+/- 500 { +/- 5000 }
FKC□48	-0.1 to + 30 {-1 to + 300}	30 { 300 }	3000 { 30000 }	+/- 3000 { +/- 30000 }

Remark : To minimize environmental influence, span should be greater than 1/40 of the max. span in most applications.

- Lower limit of static pressure (vacuum limit) ;  
Silicone fill sensor: See Fig. 1  
Fluorinated fill sensor: 66kPa abs (500mmHg abs) at temperature below 60°C
- The maximum span of each sensor can be converted to different units using factors as below.  
1MPa = 10<sup>3</sup>KPa = 10bar = 10.19716kgf/cm<sup>2</sup> = 145.0377psi  
1kpa = 10mbar = 101.9716mmH<sub>2</sub>O = 4.01463inH<sub>2</sub>O

**Over range limit:** To maximum static pressure limit

**Output signal:** 4 to 20mA DC (linear or square root) with digital signal superimposed on the 4 to 20mA signal

**Power supply:** Transmitter operates on 10.5V to 45V DC at transmitter terminals.  
10.5V to 32V DC for the units with optional arrester.

**Load limitations:** see figure below

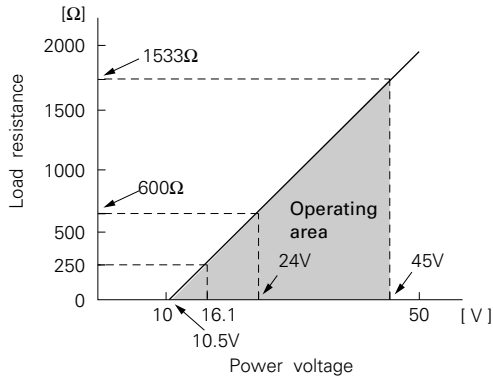

Note: For communication with HHC<sup>(1)</sup> (Model: FXW), min. of 250 Ω required.

**Hazardous locations:**

Authorities	Flameproof
ATEX	Ex II 2 GD EEx d IIC T6 IP66/67 T85°C Tamb = -40°C to +65°C EEx d IIC T5 IP66/67 T100°C Tamb = -40°C to +85°C
Factory Mutual	Class I Div.1 Groups B, C, D T6 Type 4X Class II III Div.1 Groups E, F, G T6 Type 4X Tamb max = +60°C
CSA	Class I Div.1 Groups C, D Class II Div.1 Groups E, F, G Class III Div.1  Note) "Seal Not Required" enclosure is allowed.
TIIS	Ex do IIB+H <sub>2</sub> T4 Tamb max = +55°C Maximum process temp. = +120°C
IECEX Scheme /SAA	Ex d IIC T5 IP66/67 <b>pending</b> Tamb = -40°C to +85°C Ex d IIC T6 IP66/67 <b>pending</b> Tamb = -40°C to +65°C

Authorities	Intrinsic safety																					
ATEX	Ex II 1 GD EEx ia IIC T5 Tamb = -40°C to +40°C EEx ia IIC T4 Tamb = -40°C to +80°C  Entity Parameters: Ui=28V, li=93.3mA, Pi=0.66W, Ci=27nF (Without Arrester), Ci=34.2nF (With Arrester), Li=1.134mH																					
Factory Mutual	Class I II III Div.1 Groups A, B, C, D, E, F, G T4 Entity Type 4X <table border="1"> <thead> <tr> <th colspan="2">Model code</th> <th>Tamb</th> </tr> <tr> <th>9th digit</th> <th>13th digit</th> <th></th> </tr> </thead> <tbody> <tr> <td>A,B,C,D,J</td> <td>Y,G,N</td> <td>-40°C to +85°C</td> </tr> <tr> <td>L,P,M,1,2,3</td> <td>Y,G,N</td> <td>-20°C to +80°C</td> </tr> <tr> <td>Q,S,N,4,5,6</td> <td>Y,G,N</td> <td>-20°C to +60°C</td> </tr> <tr> <td>E,F,G,H,K</td> <td>Y,G,N</td> <td>-40°C to +60°C</td> </tr> <tr> <td>-</td> <td>W,A,D</td> <td>-10°C to +60°C</td> </tr> </tbody> </table> Entity Parameters: Vmax=42.4V, Imax=113mA, Pi=1W, Ci=34.2nF, Li=1.134mH	Model code		Tamb	9th digit	13th digit		A,B,C,D,J	Y,G,N	-40°C to +85°C	L,P,M,1,2,3	Y,G,N	-20°C to +80°C	Q,S,N,4,5,6	Y,G,N	-20°C to +60°C	E,F,G,H,K	Y,G,N	-40°C to +60°C	-	W,A,D	-10°C to +60°C
Model code		Tamb																				
9th digit	13th digit																					
A,B,C,D,J	Y,G,N	-40°C to +85°C																				
L,P,M,1,2,3	Y,G,N	-20°C to +80°C																				
Q,S,N,4,5,6	Y,G,N	-20°C to +60°C																				
E,F,G,H,K	Y,G,N	-40°C to +60°C																				
-	W,A,D	-10°C to +60°C																				
CSA	Class I Div.1 Groups A, B, C, D Class II Div.1 Groups E, F, G Class III Div.1 Temp Code T4 Tamb max = +40°C Temp Code T3C Tamb max = +85°C Entity Parameters: Vmax=28V, Imax=93mA, Ci=27nF (Without Arrester), Ci=34.2nF (With Arrester), Li=1.4mH																					
TIIS	Ex ia IIC T4 Tamb max = +60°C Entity Parameters: Ui=28V, li=94.3mA, Pi=0.66W, Ci=32.6nF, Li=1.134mH																					
IECEX Scheme /SAA	Ex ia IIC T4 IP66/67 Tamb = -40°C to +70°C Ex ia IIC T5 IP66/67 Tamb = -40°C to +50°C Entity Parameters: Ui=28V, li=93.3mA, Pi=0.66W, Ci=0.033μF, Li=1.034mH																					

Authorities	Type n Nonincendive																				
ATEX	Ex II 3 GD EEx nL IIC T5 Tamb = -40°C to +40°C EEx nL IIC T4 Tamb = -40°C to +80°C Specific Parameters: Model without arrester: Ui=42.4V, Ii=113mA, Pi=1W, Ci=27nF, Li=1.134mH Model with arrester: Ui=32V, Ii=113mA, Pi=1W, Ci=34.2nF, Li=1.134mH  EEx nAL IIC T5 Tamb = -40°C to +40°C EEx nAL IIC T4 Tamb = -40°C to +80°C Specific Parameters: Model without arrester: Umax=42.4V, Imax=113mA, Pmax=1W Model with arrester: Umax=32V, Imax=113mA, Pmax=1W																				
Factory Mutual	Class I II III Div.2 Groups A, B, C, D, F, G T4 Entity Type 4X  <table border="1"> <thead> <tr> <th colspan="2">Model code</th> <th rowspan="2">Tamb</th> </tr> <tr> <th>9th digit</th> <th>13th digit</th> </tr> </thead> <tbody> <tr> <td>A,B,C,D,J</td> <td>Y,G,N</td> <td>-40°C to +85°C</td> </tr> <tr> <td>L,P,M,1,2,3</td> <td>Y,G,N</td> <td>-20°C to +80°C</td> </tr> <tr> <td>Q,S,N,4,5,6</td> <td>Y,G,N</td> <td>-20°C to +60°C</td> </tr> <tr> <td>E,F,G,H,K</td> <td>Y,G,N</td> <td>-40°C to +60°C</td> </tr> <tr> <td>-</td> <td>W,A,D</td> <td>-10°C to +60°C</td> </tr> </tbody> </table>	Model code		Tamb	9th digit	13th digit	A,B,C,D,J	Y,G,N	-40°C to +85°C	L,P,M,1,2,3	Y,G,N	-20°C to +80°C	Q,S,N,4,5,6	Y,G,N	-20°C to +60°C	E,F,G,H,K	Y,G,N	-40°C to +60°C	-	W,A,D	-10°C to +60°C
Model code		Tamb																			
9th digit	13th digit																				
A,B,C,D,J	Y,G,N	-40°C to +85°C																			
L,P,M,1,2,3	Y,G,N	-20°C to +80°C																			
Q,S,N,4,5,6	Y,G,N	-20°C to +60°C																			
E,F,G,H,K	Y,G,N	-40°C to +60°C																			
-	W,A,D	-10°C to +60°C																			
CSA	Class I Div.2 Groups A, B, C, D Class II Div.2 Groups E, F, G Class III Div.2 Temp Code T4 Tamb max = +40°C Temp Code T3C Tamb max = +85°C Entity Parameters: Vmax=28V, Ci=27nF (Without Arrester), Ci=34.2nF (With Arrester), Li=1.4mH																				
TIIS	-																				
IECEx Scheme /SAA	-																				

**Zero/span adjustment:**

Zero and span are adjustable from the HHC<sup>(1)</sup>. Zero and span are also adjustable externally from the adjustment screw (span adjustment is not available with 9th digit code "L, P, M, Q, S, N").

**Damping:**

Adjustable from HHC or local adjustment unit with LCD display. The time constant is adjustable between 0.12 to 32 seconds.

**Zero elevation/suppression:**

-100% to +100% of URL

**Normal/reverse action:**

Selectable from HHC<sup>(1)</sup>

**Indication:**

Analog indicator or 5-digit LCD meter, as specified.

**Burnout direction:** Selectable from HHC<sup>(1)</sup>

If self-diagnostic detect transmitter failure, the analog signal will be driven to either "Output Hold", "Output Overscale" or "Output Underscale" modes.

**"Output Hold":**

Output signal is hold as the value just before failure happens.

**"Output Overscale":**

Adjustable within the range 20.8mA to 21.6mA from HHC<sup>(1)</sup>

**"Output Underscale":**

Adjustable within the range 3.2mA to 3.8mA from HHC<sup>(1)</sup>

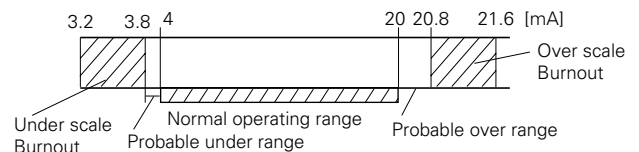

**Loop-check output:**

Transmitter can be configured to provide constant signal 3.8mA through 21.6mA by HHC<sup>(1)</sup>.

**Temperature limit:**

Ambient: -40 to +85°C  
 (-20 to +80°C for LCD indicator)  
 (-40 to +60°C for arrester option)  
 (-10 to +60°C for fluorinated oil filled transmitters)  
 For explosionproof units (flameproof or intrinsic safety), ambient temperature must be within the limits specified in each standard.

Process: -40 to +120°C for silicone fill sensor  
 -20 to +80°C for fluorinated oil fill sensor

Storage: -40 to +90°C

**Humidity limit:**

0 to 100% RH

**Communication:**

With HHC<sup>(1)</sup> (Model FXW, consult Data Sheet No. EDS8-47), following information can be remotely displayed or reconfigured.

Note: HHC's version must be more than 6.0 (or FXW □□□□1-□3), for FCX-A II.

Items	Display	Set
Tag No.	✓	✓
Model No.	✓	✓
Serial No.	✓	—
Engineering unit	✓	✓
Range limit	✓	—
Measuring range	✓	✓
Damping	✓	✓
Output mode	Linear	✓
	Square root	✓
Burnout direction	✓	✓
Calibration	✓	✓
Output adjust	—	✓
Data	✓	—
Self diagnoses	✓	—
Printer	—	—
External switch lock	✓	✓
Transmitter display	✓	✓
Linearize	✓	✓
Rerange	✓	✓

**Programmable output linearization function:**

Output signal can be characterized with "14 points linear approximation function" from HHC<sup>(1)</sup>.

**EMC Conformity:** EN61326 CE

(Note) (1) HHC: Hand Held Communicator

### Performance specifications for linear output

Reference conditions, silicone oil fill, 316SS isolating diaphragms, 4 to 20mA analog output in linear mode.

**Accuracy rating:** (including linearity, hysteresis, and repeatability)

**Max span above 32kPa model:**

For spans greater than 1/10 of URL:  $\pm 0.07\%$  of span  
For spans below 1/10 of URL:

$$\pm \left( 0.02 + 0.05 \frac{0.1 \times \text{URL}}{\text{Span}} \right) \% \text{ of span}$$

**Max span 1kPa, 6kPa model:**

For spans greater than 1/10 of URL:  $\pm 0.1\%$  of span  
For spans below 1/10 of URL:

$$\pm \left( 0.05 + 0.05 \frac{0.1 \times \text{URL}}{\text{Span}} \right) \% \text{ of span}$$

**Stability:**  $\pm 0.1\%$  of upper range limit (URL) for 3 years for 6th digit code 3, 5, 6, 8.

**Temperature effect:**

Effects per 28°C change between the limits of -40°C and +85°C

Range code (6th digit in Code symbols)	Zero shift	Total effect
"1"/1kPa (10mbar) max. span "2"/6kPa (60mbar) max. span	$\pm \left( 0.125 + 0.1 \frac{\text{URL}}{\text{Span}} \right) \%$	$\pm \left( 0.15 + 0.1 \frac{\text{URL}}{\text{Span}} \right) \%$
"3"/32kPa (320mbar) max. span "5"/130kPa (1300mbar) max. span "6"/500kPa (5000mbar) max. span "8"/3000kPa (30000mbar) max. span	$\pm \left( 0.075 + 0.0125 \frac{\text{URL}}{\text{Span}} \right) \%$	$\pm \left( 0.095 + 0.0125 \frac{\text{URL}}{\text{Span}} \right) \%$

**Static pressure effect:**

Static pressure code (5th digit in Code symbols)	Zero shift (% of URL)
"1" / 1kPa (10m bar) sensor "2" / 6kPa (60 m bar) sensor	$\pm 0.2\% / 1\text{MPa} (10\text{bar})$ $\pm 0.2\% / 3.2\text{MPa} (32\text{bar})$
"2" "3" "4"	$\pm 0.05\% / 10\text{MPa} (100\text{bar})$

**Overrange effect:**

Static pressure code (5th digit in Code symbols)	Zero shift (% of URL)
"1" / 1kPa (10m bar) sensor "2" / 6kPa (60m bar) sensor	$\pm 0.3\% / 1\text{MPa} \{10\text{bar}\}$ $\pm 0.1\% / 3.2\text{MPa} \{32\text{bar}\}$
"2" "3" "4"	$\pm 0.1\% / 10\text{MPa} \{100\text{bar}\}$ $\pm 0.1\% / 16\text{MPa} \{160\text{bar}\}$ $\pm 0.25\% / 42\text{MPa} \{420\text{bar}\}$

### Performance specifications for square root output

**Accuracy rating:**

Output	Span	
	over $0.1 \times \text{URL}$	below $0.1 \times \text{URL}$
50 to 100%	$\pm 0.07\%$	$\pm (0.02 + 0.05 \times 0.1 \times \text{URL}/\text{Span})\%$
20 to 50%	$\pm 0.175\%$	$\pm 2.5 \times (0.02 + 0.05 \times 0.1 \times \text{URL}/\text{Span})\%$
10 to 20%	$\pm 0.35\%$	$\pm 5 \times (0.02 + 0.05 \times 0.1 \times \text{URL}/\text{Span})\%$

**Max span 1kPa, 6kPa model:**

Output	Accuracy
50 to 100%	$\pm 0.1\%$
20 to 50%	$\pm 0.25\%$
10 to 20%	$\pm 0.5\%$

**Temperature effect:**

Effects per 55°C change between the limits of -40°C and +85°C

Range code	Shift at 20% output point
"1" and "2"	$\pm \left( 0.375 + 0.25 \frac{\text{URL}}{\text{Span}} \right) \%/28^\circ\text{C}$
"3" through "8"	$\pm \left( 0.24 + 0.03125 \frac{\text{URL}}{\text{Span}} \right) \%/28^\circ\text{C}$

**Low flow cut-off:** Customer configurable for any point between 0 to 20% of output

**Supply voltage effect:**

Less than 0.005% of calibrated span per 1V

**RFI effect:**

Less than 0.2% of URL for the frequencies of 20 to 1000MHz and field strength 30 V/m when electronics covers on.  
(Classification: 2-abc: 0.2% span per SAMA PMC 33.1)

**Update period:** 120 msec \*)

**Step response:** (without electrical damping)

Range code (6th digit in code symbols)	Time constant*)	Dead time*)
"1"	0.8 s	0.2 s
"2"	0.5 s	
"3"	0.3 s	
"5" through "8"	0.2 s	

\*) Faster response is available as option (maximum update rate: 25 times per second).

**Mounting position effect:**

Zero shift, less than 0.12kPa {1.2m bar} for a 10° tilt in any plane.

No effect on span.

This error can be corrected by adjusting Zero.

**Dielectric strength:**

500V AC, 50/60Hz 1 min., between circuit and earth.

**Insulation resistance:**

More than 100MΩ at 500V DC.

**Turn-on time:** 4 sec.

**Internal resistance for external field indicator:**

12Ω or less

## Physical specifications

### Electrical connections:

G1/2, 1/2-14 NPT, Pg13.5, or M20 × 1.5 conduit, as specified.

And 1 conduit or 2 conduits, as specified.

### Process connections:

1/4-18 NPT or Rc1/4 on 54mm centers, as specified.

Meets DIN 19213.

### Process-wetted parts material:

Material code (7th digit in Code symbols)	Process cover	Diaphragm	Wetted sensor body	Vent/drain
V	316 stainless steel(*)	316L stainless steel	316 stainless steel	316/316L stainless steel
H	316 stainless steel(*)	Hastelloy-C	Hastelloy-C lining	316/316L stainless steel
J	316 stainless steel(*)	316L stainless steel +Au coating	316 stainless steel	316/316L stainless steel
M	316 stainless steel(*)	Monel	Monel lining	316/316L stainless steel
T	316 stainless steel(*)	Tantalum	Tantalum lining	316/316L stainless steel
B	Hastelloy-C lining	Hastelloy-C	Hastelloy-C lining	Hastelloy-C
L	Monel lining	Monel	Monel lining	Monel
U	Tantalum lining	Tantalum	Tantalum lining	Hastelloy-C

Note: (\*) SCS14A per JIS G 5121 (equivalent CF8M per ASTM A351/A351M)

Remarks: Sensor O-rings: Viton O-ring and teflon gasket selectable.

Availability of above material design depends on ranges and static pressure. Refer to "Code symbols".

### Non-wetted parts material:

Electronics housing: Low copper die-cast aluminum alloy finished with epoxy/polyurethane double coating (standard), or 316 stainless steel (SCS14A per JIS G5121), as specified.

Bolts and nuts: Cr-Mo alloy (standard), 304 stainless steel (for static pressure code "1", "2", and "3" only), or 630 stainless steel (for static pressure code "3" and "4" only). Static pressure rating for code "3" with 304 stainless steel bolts is degraded to 10MPa.

Fill fluid: Silicone oil (standard) or fluorinated oil

Mounting bracket: 304 stainless steel

### Environmental protection:

IEC IP67 and NEMA 6/6P

### Mounting:

On 60.5mm(JIS 50A) pipe using mounting bracket, direct wall mounting, or direct process mounting.

### Mass{weight}:

Transmitter approximately 4.4kg without options.

Add; 0.5kg for mounting bracket

0.8kg for indicator option

4.5kg for stainless steel housing option

## Optional features

### Indicator:

A plug-in analog indicator (2.5% accuracy) can be housed in the electronics compartment or in the terminal box of the housing.

An optional 5-digit LCD meter with engineering unit is also available.

### Local adjustment unit with LCD display:

An optional 5-digit LCD meter with Zero/ Span adjustment function, loop-check function and damping adjustment function, is available.

### Arrester:

A built-in arrester protects the electronics from lightning surges.

Lightning surge immunity:

4kV (1.2 × 50μs)

### Oxygen service:

Special cleaning procedures are followed throughout the process to maintain all process wetted parts oil-free.

The fill fluid is fluorinated oil.

### Chlorine service:

The fill fluid is fluorinated oil.

### Degreasing:

Process-wetted parts are cleaned, but the fill fluid is standard silicone oil. Not for use on oxygen or chlorine measurement.

### NACE specification:

Metallic materials for all pressure boundary parts comply with NACE MR-01-75. ASTM B7M or L7M bolts and 2HM nuts (Class II) are available.

Static pressure rating for code "3" (16 MPa) is degraded to 10MPa.

### Vacuum service:

Special silicone oil and filling procedure are applied.

See Fig. 1.

### Optional tag plate:

An extra stainless steel tag with customer tag data is wired to the transmitter.

### Coating of cell:

Cell's surface is finished with epoxy/polyurethane double coating. Specify if environment is extremely corrosive.

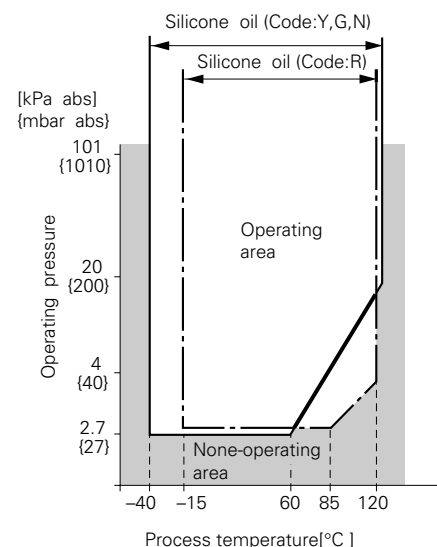

Fig. 1 Relation between process temperature and operating pressure

## ACCESSORIES

- Oval flanges:** (Model FFP, refer to Data Sheet No. EDS6-10)  
Converts process connection to 1/2-14 NPT or to Rc1/2; in carbon steel or in 316 stainless steel.
- Equalizing valves:** (Model FFN, refer to Data Sheet No. EDS6-10)  
Available in Carbon steel or in 316 stainless steel and in pressure rating 16MPa or 42MPa.
- Hand-held communicator:** (Model FXW, refer to Data Sheet No. EDS 8-47)
- Z/S board:** Parts No.=ZZPFCX4-A070  
When Z/S board is mounted on the FCX-AII amplifier unit, external adjustment screw will be available for zero and span adjustment.

## ORDERING INFORMATION

When ordering this instrument, specify:

1. CODE SYMBOLS
2. Measuring range
3. Output orientation (burnout direction) when abnormality is occurred in the transmitter.  
Hold / Overscale (21.6mA) / Underscale (3.2mA)  
Unless otherwise specified, output hold function is supplied.
4. Output mode (linear or square root output)  
Unless otherwise specified, output mode is linear.
5. Indication method (indicated value and unit) in case of the actual scale (code D, H, P, S on 9th digit).
6. Tag No. (up to 26 alphanumerical characters), if required.

# CODE SYMBOLS

Digit	Description				Note	1	2	3	4	5	6	7	8	9	10	11	12	13	14	15	21	← Digit No. of code	
						F	K	C					4										
4	<Connection>																						
	Process connection	Oval flange screw	Conduit connection																				
	Rc1/4	7/16-20UNF	G1/2 (×1)		Combination with 12th digit code "C, E, P, Q" are not available.																		
	1/4-18NPT	7/16-20UNF	1/2-14NPT (×1)																				
	1/4-18NPT	M10 (or M12)(*1)	Pg 13.5 (×1)																				
	1/4-18NPT	M10 (or M12)(*1)	M20×1.5 (×1)																				
	Rc1/4	7/16-20UNF	G1/2 (×2)																				
	1/4-18NPT	7/16-20UNF	1/2-14NPT (×2)																				
	1/4-18NPT	M10 (or M12)(*1)	Pg 13.5 (×2)		Note 1																		
	1/4-18NPT	M10 (or M12)(*1)	M20×1.5 (×2)		Note 1																		
1/4-18NPT	7/16-20UNF	Pg 13.5 (×2)		Note 1																			
5, 6, 7	<Span and materials>																						
	Static pressure [MPa] {bar}	Span limit (*2) [kPa] (m bar)	Process cover	Diaphragm	Wetted cell body	Note 2																	
	-0.1 to +3.2 {-1 to +32}	0.1...1 {1...10}	316 stainless steel 316 stainless steel	316L stainless steel 316L stainless steel +Au coating	316 stainless steel 316 stainless steel																		11V 11J
			316 stainless steel	Hast. C	Hast. C lining																		11H
	-0.1 to +10 {-1 to 100}	0.1...6 {1...60}	316 stainless steel 316 stainless steel	316L stainless steel 316L stainless steel +Au coating	316 stainless steel 316 stainless steel																		22V 22J
			316 stainless steel	Hast. C	Hast. C lining																		22H
	-0.1 to +16 {-1 to +160}	0.32...32 {3.2...320}	316 stainless steel 316 stainless steel	316L stainless steel 316L stainless steel +Au coating	316 stainless steel 316 stainless steel																		33V 33J
			316 stainless steel	Hast. C	Hast. C lining																		33H
			316 stainless steel	Monel	Monel lining																		33M
			316 stainless steel	Tantalum	Tantalum lining																		33T
		1.3...130 {13...1300}	316 stainless steel 316 stainless steel	316L stainless steel 316L stainless steel +Au coating	316 stainless steel 316 stainless steel																		35V 35J
			316 stainless steel	Hast. C	Hast. C lining																		35H
			316 stainless steel	Monel	Monel lining																		35M
			316 stainless steel	Tantalum	Tantalum lining																		35T
		5...500 {50...5000}	316 stainless steel 316 stainless steel	316L stainless steel 316L stainless steel +Au coating	316 stainless steel 316 stainless steel																		36V 36J
			316 stainless steel	Hast. C	Hast. C lining																		36H
			316 stainless steel	Monel	Monel lining																		36M
			316 stainless steel	Tantalum	Tantalum lining																		36T
		30...3000 {300...30000}	316 stainless steel 316 stainless steel	316L stainless steel 316L stainless steel +Au coating	316 stainless steel 316 stainless steel																		38V 38J
			316 stainless steel	Hast. C	Hast. C lining																		36H
			316 stainless steel	Monel	Monel lining																		36M
			316 stainless steel	Tantalum	Tantalum lining																		36T
	-0.1 to +42 {-1 to +420}	0.32...32 {3.2...320}	316 stainless steel 316 stainless steel	316L stainless steel 316L stainless steel +Au coating	316 stainless steel 316 stainless steel																		43V 43J
			316 stainless steel	Hast. C	Hast. C lining																		43H
			316 stainless steel	Monel	Monel lining																		43M
		1.3...130 {13...1300}	316 stainless steel 316 stainless steel	316L stainless steel 316L stainless steel +Au coating	316 stainless steel 316 stainless steel																		45V 45J
			316 stainless steel	Hast. C	Hast. C lining																		45H
			316 stainless steel	Monel	Monel lining																		45M
		5...500 {50...5000}	316 stainless steel 316 stainless steel	316L stainless steel 316L stainless steel +Au coating	316 stainless steel 316 stainless steel																		46V 46J
			316 stainless steel	Hast. C	Hast. C lining																		46H
			316 stainless steel	Monel	Monel lining																		46M
	-0.1 to +30 {-1 to +300}	30...3000 {300...30000}	316 stainless steel 316 stainless steel	316L stainless steel 316L stainless steel +Au coating	316 stainless steel 316 stainless steel																		48V 48J
			316 stainless steel	Hast. C	Hast. C lining																		46H
			316 stainless steel	Monel	Monel lining																		46M
	-0.1 to +10 {-1 to +100}	0.32...32 {3.2...320}	Hast. C lining Monel lining Tantalum lining	Hast. C Monel Tantalum	Hast. C lining Monel lining Tantalum lining																		23B 23L 23U
		1.3...130 {13...1300}	Hast. C lining Monel lining Tantalum lining	Hast. C Monel Tantalum	Hast. C lining Monel lining Tantalum lining																		25B 25L 25U
		5...500 {50...5000}	Hast. C lining Monel lining Tantalum lining	Hast. C Monel Tantalum	Hast. C lining Monel lining Tantalum lining																		26B 26L 26U

Note 1: (\*1) The thread is M12, if 42MPa {420bar} static pressure is specified.  
 Note 2: (\*2) 100: 1 turn down is possible, but should be used at the span greater than 1/40 of the maximum span for better performance.

Digit	Description	Note	1 2 3 4 5 6 7 8								9 10 11 12 13			14 15		21 ← Digit No. of code	
			F	K	C												
9	<Indicator and arrester>																
	<u>Indicator</u>	<u>Arrester</u>															
	None	None									A						
	Analog, 0 to 100% linear scale	None									B						
	Analog, 0 to 100% sq. root scale	None (*3)	Note 3								C						
	Analog, custom scale	None									D						
	Analog, double scale (Linear and sq. root)	None									J						
	None	Yes									E						
	Analog, 0 to 100% linear scale	Yes									F						
	Analog, 0 to 100% sq. root scale	Yes (*3)	Note 3								G						
	Analog, custom scale	Yes									H						
	Analog, double scale (Linear and sq. root)	Yes									K						
	Digital, 0 to 100%	None									L						
	Digital, custom scale	None									P						
	Digital 0 to 100% square root	None								M							
	Digital, 0 to 100%	Yes								Q							
	Digital, custom scale	Yes								S							
	Digital 0 to 100% square root	Yes								N							
	Digital, 0 to 100%	None								1							
	(Local adjustment unit with LCD display)	None								2							
Digital, custom scale	None								3								
(Local adjustment unit with LCD display)	None								4								
Digital, 0 to 100%	Yes								5								
(Local adjustment unit with LCD display)	Yes								6								
Digital, custom scale	Yes																
(Local adjustment unit with LCD display)	Yes																
Digital, 0 to 100% square root	Yes																
(Local adjustment unit with LCD display)	Yes																
10	<Approvals for hazardous locations>																
	None (for ordinary locations)										A						
	TIIS, Flameproof (Conduit seal) (Available for 4th digit code "A", "S")										B						
	TIIS, Flameproof (Cable gland seal) (Available for 4th digit code "A", "S")										C						
	FM, Flameproof (or explosionproof) (Available for 4th digit code "B", "T")										D						
	CSA, Flameproof (or explosionproof) (Available for 4th digit code "B", "T")										E						
	ATEX, Flameproof										X						
	IECEX Scheme/SAA, Flameproof (Approval pending)										R						
	TIIS, Intrinsic safety										G						
	FM, Intrinsic safety and Nonincendive										H						
	CSA, Intrinsic safety and Nonincendive										J						
	ATEX, Intrinsic safety										K						
	ATEX, Type n										P						
IECEX Scheme/SAA, Intrinsic safety										T							
FM, Combined of Flameproof and Intrinsic safety										V							
11	<Vent/ drain and mounting bracket>																
	<u>Vent/drain</u> <u>Mounting bracket</u>																
	Standard      None	Specify "A" or "C" for the 7th digit code "B", "L", or "U"									A						
	Standard      Yes, stainless steel										C						
	Side      None										D						
Side      Yes, stainless steel										F							
12	<Options>																
	<u>Extra SS tag plate</u> <u>Stainless steel elec, housing</u> <u>Coating of cell</u>																
	None	None	Note 4														
	Yes	None															
	None	Yes															
	Yes (*4)	Yes															
	None	None															
	Yes	None															
None	Yes																
Yes	Yes																
13	<Special applications and fill fluid>																
	<u>Treatment</u> <u>Fill fluid</u>																
	Standard      Silicone oil																
	Standard      Fluorinated oil																
	Degreasing      Silicone oil																
	Oxygen service      Fluorinated oil (7th digit code "V", "J" only)																
	Chlorine service      Fluorinated oil (7th digit code "H", "T", "B", "U")																
	NACE specification      Silicone oil (Not available for 7th digit code "T", "U" and 15th digit code "A", "B")																
Vacuum service      Silicone oil for vacuum use																	
14	<Sensor O-ring / Gasket>																
	Viton (O-ring)																
	Teflon (gasket)																

Note 3: (\*3) In case of square root output mode, square root scale is not available.

Note 4: (\*4) Customer tag number can be engraved on standard stainless steel name plate. If extra tag plate is required, select "Yes".



Digit	Description	Note	1	2	3	4	5	6	7	8	9	10	11	12	13	14	15	21	← Digit No. of code
15	<Bolt/nut> (*8) Cr-Mo alloy hexagon socket head cap screw/carbon steel nut Cr-Mo alloy hexagon bolt/nut NACE bolt/nut (ASTM A193 B7M/A194 2HM) } (*5) NACE bolt/nut (ASTM A320 L7M/A194 2HM) } (*5) 304 stainless steel bolt/304 stainless steel nut (*6) 630 stainless steel bolt/304 stainless steel nut (*7)	Note 8   Note 5  Note 6 Note 7	F	K	C					4	-								
21	<Other options> (*9) Instruction manual unattached	Note 9																	L

Note 5: (\*5) Static pressure should be -0.1 to +10MPa{-1 to +100bar}.

Note 6: (\*6) Available for 5th digit code "1", "2", "3". In case of stainless steel bolt with 5th digit code "3", static pressure should be -0.1 to +10MPa {-1 to + 100bar}.

Note 7: (\*7) Available for 5th digit code "3", "4".

Note 8: (\*8) In case of tropical use, select stainless bolts and nuts.

Note 9: (\*9) If other option is not necessary, 21st digit code is blank.  
In case of 21st digit code is blank, instruction manual attached.

## OUTLINE DIAGRAM (Unit:mm)

< 7th digit code : V, H, M, T, J >

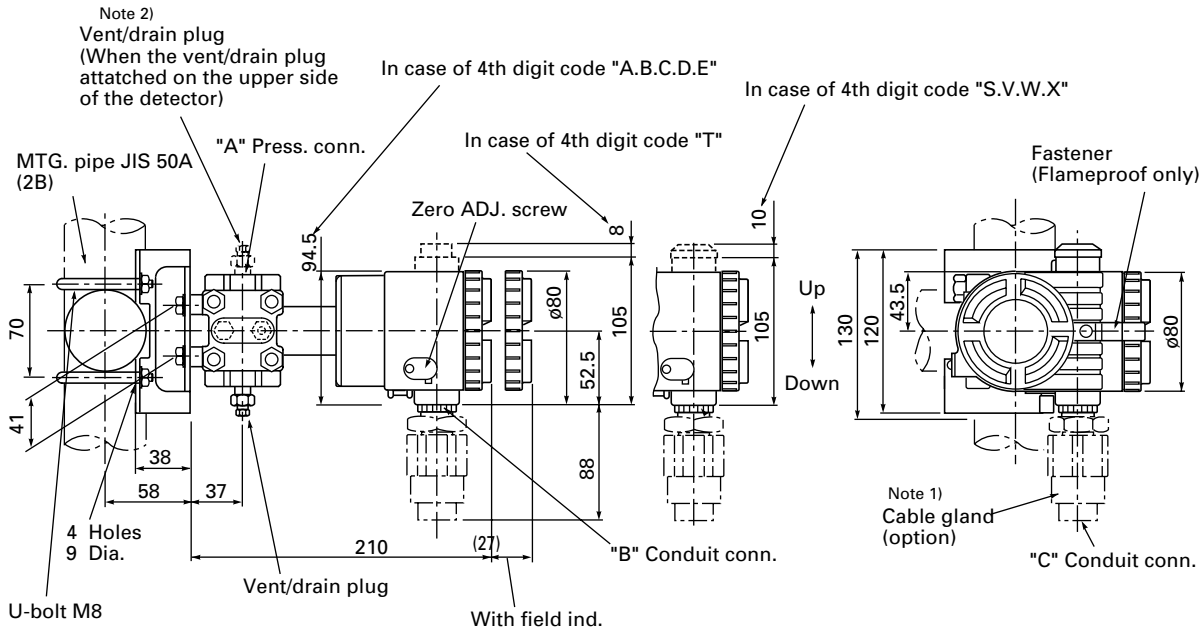

Detail "A"  
(Press. conn.)

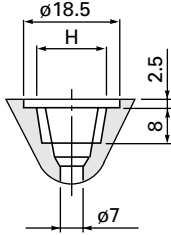

See table 1

Detail "B"  
(Conduit conn.)

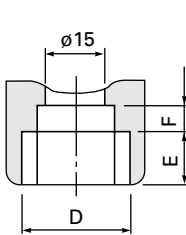

See table 1

Detail "C"

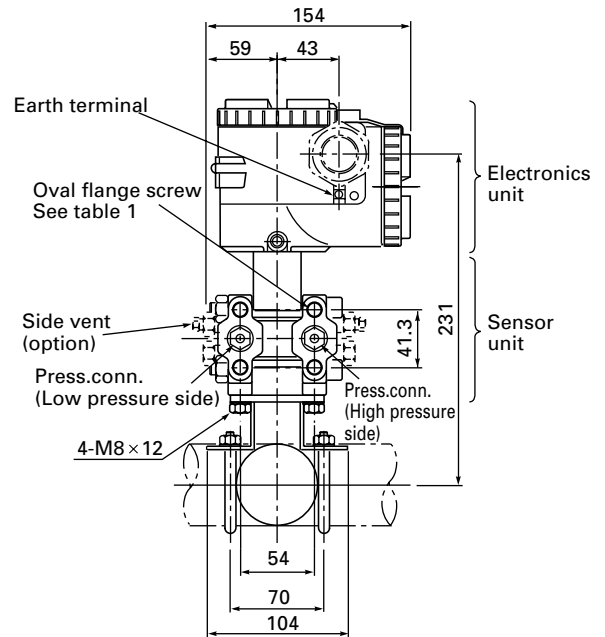
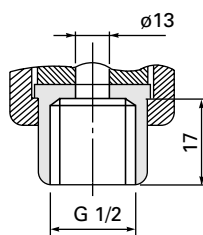

4th digit of the code symbols	Conduit conn.			Press. conn.	Oval flange screw
	D	E	F	H	
3, 4, A, S	G1/2	17	8	Rc1/4	7/16-20UNF SCREW DEPTH15
B, T	1/2-14NPT	16	5	1/4-18NPT	7/16-20UNF SCREW DEPTH15
C, V	Pg13.5	8	4.5	1/4-18NPT	M10 SCREW DEPTH15
D, W	M20 × 1.5	16	5	1/4-18NPT	M10 SCREW DEPTH15
E, X	Pg13.5	8	4.5	1/4-18NPT	7/16-20UNF SCREW DEPTH15

TABLE 1

CONNECTION DIAGRAM

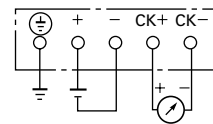

Note 1) Cable gland is supplied in case of flameproof packing type.  
ø11 cable is suitable.

Note 2) The pressure connector is located on the down side surface of the detector, when the vent/drainplug is attached on the upper side of the detector  
(when the 21th digit of the code symbols: c, e or d).

< 7th digit code : B, L, U >

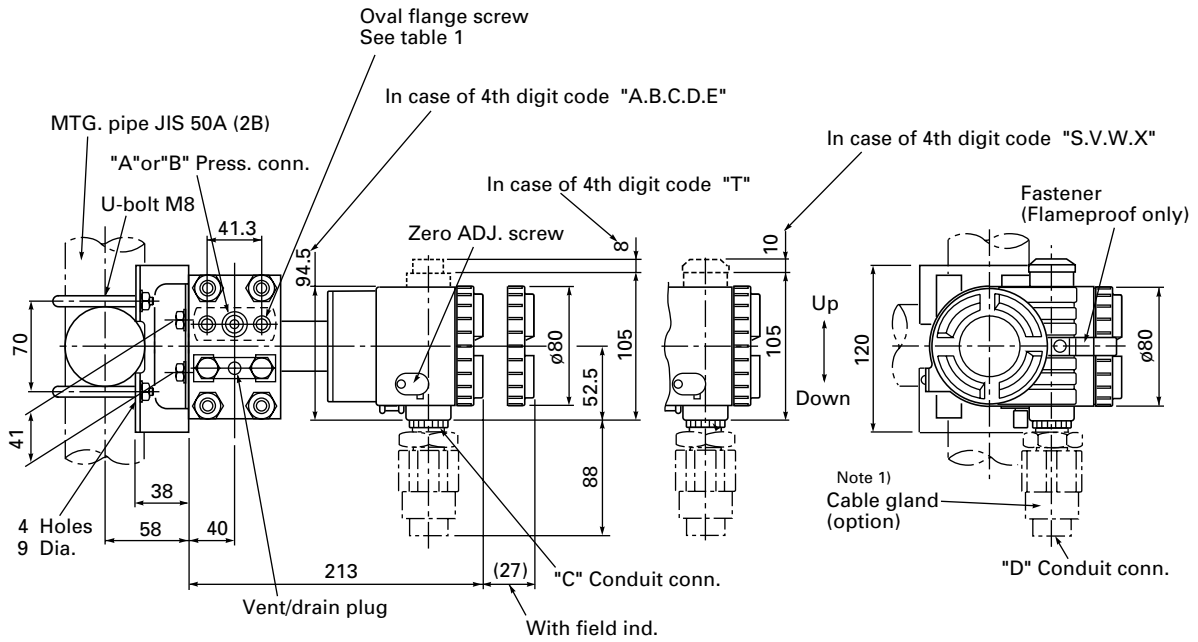

Detail "A"  
(Press. conn.)  
4TH DIGIT CODE "A, S"

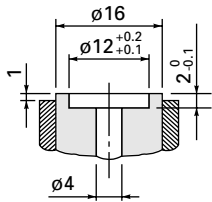

Detail "C"  
(Conduit conn.)

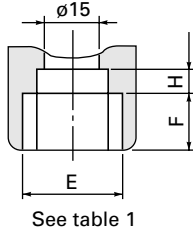

Detail "D"

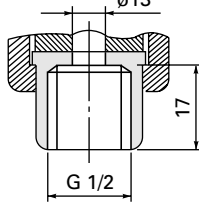

Detail "B"  
(Press. conn.)  
4TH DIGIT CODE  
"B, C, D, E, T, V, W, X"

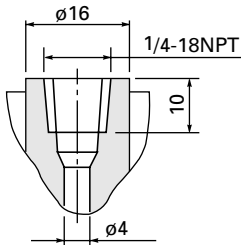

4th digit of the code symbols	Conduit conn.			Oval flange screw
	E	F	H	
3, 4, A, S	G1/2	17	8	7/16-20UNF SCREW DEPTH10
B, T	1/2-14NPT	16	5	7/16-20UNF SCREW DEPTH10
C, V	Pg13.5	8	4.5	M10 SCREW DEPTH10
D, W	M20×1.5	16	5	M10 SCREW DEPTH10
E, X	Pg13.5	8	4.5	7/16-20UNF SCREW DEPTH10

TABLE 1

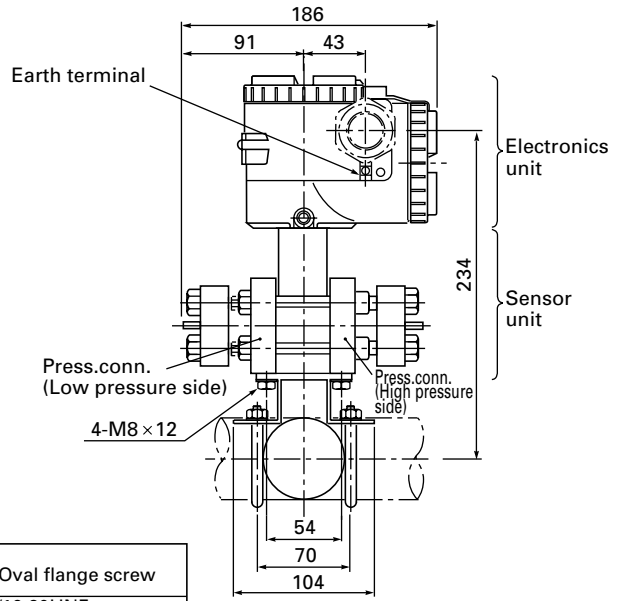

CONNECTION DIAGRAM

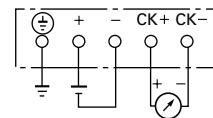

Note 1) Cable gland is supplied in case of flameproof packing type.  
ø11 cable is suitable.

The product conforms to the requirements of the Electromagnetic compatibility Directive 94/9/EC as detailed within the technical construction file number TN513035. The applicable standards used to demonstrate compliance are :

**EMI (Emission) EN61326 : 1997**  
**Class A (standard for Industrial Location)**

Frequency range MHz	Limits	Reference standard
30 to 230	40dB ( $\mu\text{V}/\text{m}$ ) quasi peak, measured at 10m distance	CISPR16-1 and CISPR16-2
230 to 1000	47dB ( $\mu\text{V}/\text{m}$ ) quasi peak, measured at 10m distance	

**EMI (Immunity) EN61326: 1997**  
**Annex A (standard for Industrial Location)**

Phenomenon	Test value	Basic standard	Performance criteria
Electrostatic discharge	4kV (Contact) 8kV (Air)	EN61000-4-2	B
Electromagnetic field	80 to 1000MHz 10V/m 80%AM (1kHz)	EN61000-4-3	A
Rated power frequency magnetic field	30A/m 50Hz	EN61000-4-8	A
Burst	2kV 5kHz	EN61000-4-4	B
Surge	1.2 $\mu\text{s}$ /50 $\mu\text{s}$ 1kV (Line to line) 2kV (Line to ground)	EN61000-4-5	B
Conducted RF	0.15 to 80MHz 3V 80%AM (1kHz)	EN61000-4-6	A

**Note) Definition of performance criteria**

**A: During testing, normal performance within the specification limits.**

**B: During testing, temporary degradation, or loss of function or performance which is self-recovering.**

 Caution on Safety

\*Before using this product, be sure to read its instruction manual in advance.

## Fuji Electric Systems Co., Ltd.

### Head Office

Gate City Ohsaki, East Tower, 11-2, Osaki 1-chome,  
Shinagawa-ku, Tokyo 141-0032, Japan

<http://www.fesys.co.jp/eng>

### Instrumentation Div.

### International Sales Dept.

No.1, Fuji-machi, Hino-city, Tokyo, 191-8502 Japan

Phone: 81-42-585-6201, 6202 Fax: 81-42-585-6187

<http://www.fic-net.jp/eng>

Information in this catalog is subject to change without notice.

Printed in Japan