

ITS 3108 (GR) and ITS 4108 (GR)

Cylindrical Plug Assembly with 90° Backshell and Rotating Clamp Nut Backshell for Heat Shrink Tubing

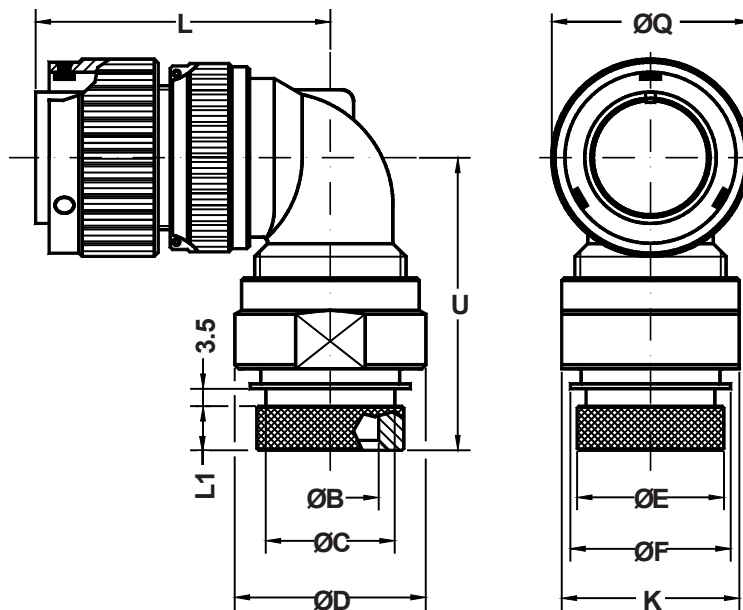
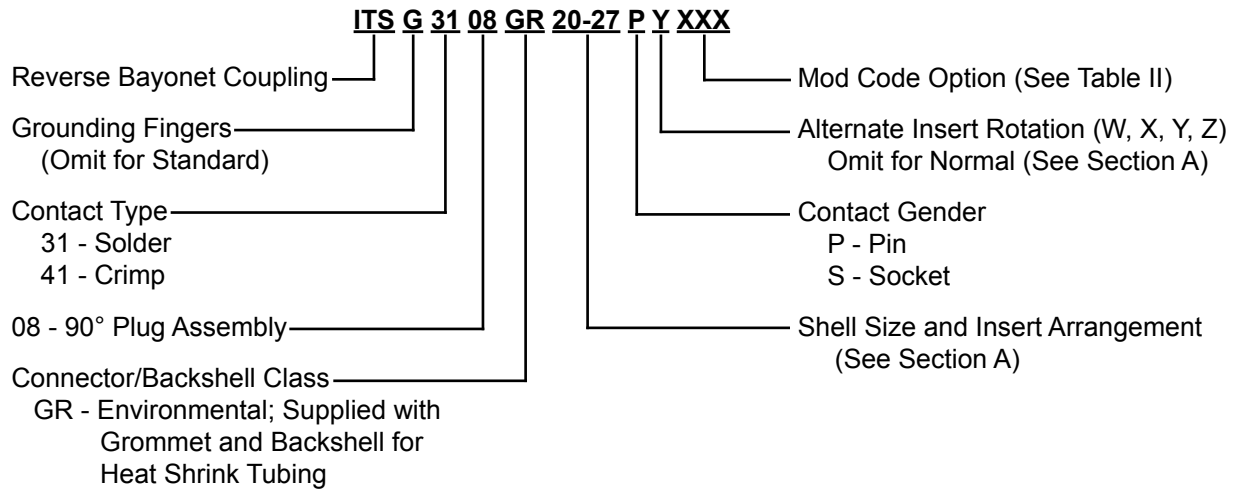

Application Notes:

1. 90° plug with backshell for heat-shrink tubing. Rotating coupling nut supplied
2. Connector/Backshell Class "GR" (environmental)—Wire sealing grommet supplied.
3. Standard materials configuration consists of aluminum alloy. For platings, see TABLE II finish options.
4. Standard contact material consists of copper alloy with silver plating or gold plating.
5. A broad range of additional connector accessories are available.
See our website and/or contact the factory for complete information.
6. Standard insert material is synthetic rubber.
Add "FR" prefix to front of part number to specify fire resistant inserts.

ITS 3108 (GR) and ITS 4108 (GR)
Cylindrical Plug Assembly with 90° Backshell
and Rotating Clamp Nut Backshell for Heat Shrink Tubing



TABLE I: DIMENSIONS

Shell Size	ØB min.	ØC ±0.1	ØD +0 -0.1	ØE ±0.1	ØF ±0.2	K Key	L Max.	L1 ±0.1	ØQ ±0.2	U Max.
10 SL	8.6	13.0	22.0	17.0	17.0	20	40	8.2	22.6	51.0
14 S	10.7	16.5	25.0	20.1	20.1	23	42	8.2	29.0	52.5
16 S	14.0	24.9	28.0	23.5	23.5	26	46	8.0	31.6	53.0
16	14.0	24.9	28.0	23.5	23.5	26	55	8.0	31.6	50.0
18	17.5	21.7	31.0	26.5	26.5	29	57	8.0	36.2	56.0
20	18.8	26.2	36.0	30.2	30.5	34	62	8.9	39.8	57.5
22	21.0	26.2	38.0	33.6	33.6	36	62	9.2	43.0	57.5
24	25.4	34.0	41.0	36.1	36.1	39	67	9.5	46.4	62.5
28	28.4	34.3	48.0	41.4	41.4	46	67	9.2	53.0	64.5
32	34.0	43.6	54.0	48.6	48.6	52	72	11.7	60.0	72.0
36	40.5	43.6	61.0	54.0	54.8	59	75	11.5	66.2	76.0
40	49.0	52.6	68.0	61.0	60.9	66	78	11.5	72.3	81.0

TABLE II: MODIFICATION CODES

CONTACT OPTIONS	
Sym	Description
B0	Connector Less Contacts
B1	Connector with Gold Plated Contacts
Omit for standard version (Silver plated)	
FINISH OPTIONS	
Sym	Description and RoHS compliant (*)
F2	Bright Nickel Plating (*)
F6	Black Electrodeposited Paint (*)
F7	Black Zn-Co Plating (*)
F8	Olive Drab Zn-Co Plating
F11	Electroless Nickel (*)
Omit for standard version (Cadmium Olive Drab Finish)	