



## Dual, 12-Bit, Parallel Input, Multiplying Digital-to-Analog Converter

### FEATURES

- $\pm 1$ LSB INL
- 2.5V to 5.5V Supply Operation
- Fast Parallel Interface:  
17ns Write Cycle
- Update Rate of 20.4MSPS
- 10MHz Multiplying Bandwidth
- $\pm 15$ V Reference Input
- Extended Temperature Range:  
 $-40^{\circ}\text{C}$  to  $+125^{\circ}\text{C}$
- 40-Lead QFN
- 12-Bit Monotonic
- 4-Quadrant Multiplication
- Power-On Reset with Brownout Detection
- Readback Function
- Industry-Standard Pin Configuration
- Pin-Compatible with the AD5405

### APPLICATIONS

- Portable Battery-Powered Instruments
- Waveform Generators
- Analog Processing
- Programmable Amplifiers and Attenuators
- Digitally-Controlled Calibration
- Programmable Filters and Oscillators
- Ultrasound

### DESCRIPTION

The DAC7822 is a dual, CMOS, 12-bit, current output digital-to-analog converter (DAC). This device operates from a 2.5V to 5.5V power supply, making it suitable for battery-powered and many other applications.

The DAC7822 operates with a fast parallel interface. Data readback allows the user to read the contents of the DAC register via the DB pins. On power-up, the internal register and latches are filled with zeroes and the DAC outputs are at zero scale.

The DAC7822 offers excellent 4-quadrant multiplication characteristics, with large signal multiplying bandwidth of 10MHz. The applied external reference input voltage ( $V_{REF}$ ) determines the full-scale output current. An integrated feedback resistor ( $R_{FB}$ ) provides temperature tracking and full-scale voltage output when combined with an external current-to-voltage precision amplifier. The DAC7822 also includes the resistors necessary for 4-quadrant multiplication and other configuration modes.

The DAC7822 is available in a 40-lead QFN package.

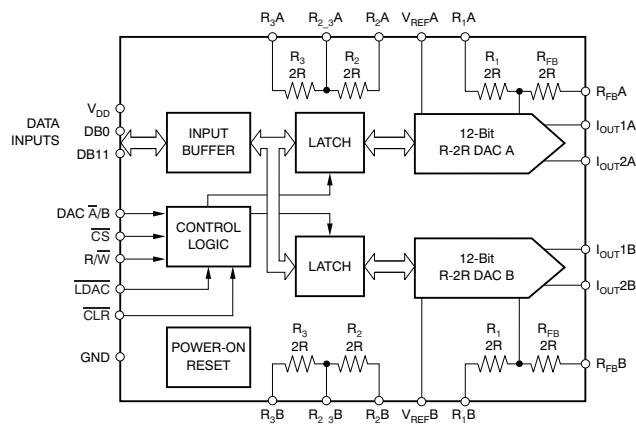

Please be aware that an important notice concerning availability, standard warranty, and use in critical applications of Texas Instruments semiconductor products and disclaimers thereto appears at the end of this data sheet.

All trademarks are the property of their respective owners.



This integrated circuit can be damaged by ESD. Texas Instruments recommends that all integrated circuits be handled with appropriate precautions. Failure to observe proper handling and installation procedures can cause damage.

ESD damage can range from subtle performance degradation to complete device failure. Precision integrated circuits may be more susceptible to damage because very small parametric changes could cause the device not to meet its published specifications.

## PACKAGE/ORDERING INFORMATION

For the most current package and ordering information, see the Package Option Addendum at the end of this document, or see the TI website at [www.ti.com](http://www.ti.com).

## ABSOLUTE MAXIMUM RATINGS<sup>(1)</sup>

Over operating free-air temperature range (unless otherwise noted).

	<b>DAC7822</b>	<b>UNIT</b>
V <sub>DD</sub> to GND	–0.3 to +7.0	V
Digital input voltage to GND	–0.3 to V <sub>DD</sub> + 0.3	V
V <sub>OUT</sub> to GND	–0.3 to V <sub>DD</sub> + 0.3	V
Operating temperature range	–40 to +125	°C
Storage temperature range	–65 to +150	°C
Junction temperature (T <sub>J</sub> max)	+150	°C
ESD Rating, HBM	2000	V
ESD Rating, CDM	1000	V

(1) Stresses above those listed under absolute maximum ratings may cause permanent damage to the device. Exposure to absolute maximum conditions for extended periods may affect device reliability.

**ELECTRICAL CHARACTERISTICS**

$V_{DD} = +2.5V$  to  $+5.5V$ ;  $I_{OUT1} = \text{Virtual GND}$ ;  $I_{OUT2} = 0V$ ;  $V_{REF} = 10V$ ;  $T_A = \text{full operating temperature}$ . All specifications  $-40^\circ\text{C}$  to  $+125^\circ\text{C}$ , unless otherwise noted.

PARAMETER	CONDITIONS	DAC7822			UNITS
		MIN	TYP	MAX	
<b>STATIC PERFORMANCE</b>					
Resolution		12			Bits
Relative accuracy				$\pm 1$	LSB
Differential nonlinearity				$\pm 1$	LSB
Output leakage current	Data = 000h, $T_A = +25^\circ\text{C}$			$\pm 1$	nA
Output leakage current	Data = 000h, $T_A = T_{MAX}$			$\pm 15$	nA
Full-scale gain error	All ones loaded to DAC register		$\pm 10$	$\pm 25$	mV
Full-scale tempco <sup>(1)</sup>			$\pm 5$		ppm/ $^\circ\text{C}$
Bipolar zero-code error	Circuit configuration as shown in <a href="#">Figure 41</a>			$\pm 25$	mV
Output capacitance	DAC latches loaded with all 1s		25	30	pF
<b>REFERENCE INPUT</b>					
$V_{REF}$ range		-15		15	V
$V_{REFA}$ , $V_{REFB}$ , Input resistance		8	10	12	k $\Omega$
$R_1$ , $R_{FB}$ resistance		17	20	25	k $\Omega$
$R_2$ , $R_3$ resistance		17	20	25	k $\Omega$
$V_{REFA}$ to $V_{REFB}$ Input Mismatch			1.6	2.5	%
$R_2$ to $R_3$ Mismatch			0.06	0.18	%
<b>LOGIC INPUTS AND OUTPUT<sup>(1)</sup></b>					
Input low voltage	$V_{IL}$	$V_{DD} = +2.5V$		0.6	V
		$V_{DD} = +5V$		0.8	V
Input high voltage	$V_{IH}$	$V_{DD} = +2.5V$	2.1		V
		$V_{DD} = +5V$	2.4		V
Input leakage current	$I_{IL}$			1	$\mu\text{A}$
Input capacitance	$C_{IL}$			10	pF
<b>POWER REQUIREMENTS</b>					
$V_{DD}$		2.5		5.5	V
$I_{DD}$ (normal operation)	Logic inputs = 0V			5	$\mu\text{A}$
$V_{DD} = +4.5V$ to $+5.5V$	$V_{IH} = V_{DD}$ and $V_{IL} = \text{GND}$		0.8	5	$\mu\text{A}$
$V_{DD} = +2.5V$ to $+3.6V$	$V_{IH} = V_{DD}$ and $V_{IL} = \text{GND}$		0.4	2.5	$\mu\text{A}$
<b>AC CHARACTERISTICS<sup>(1)</sup></b>					
Output voltage settling time				0.2	$\mu\text{s}$
Reference multiplying BW	$V_{REF} = 7V_{PP}$ , Data = FFFh		10		MHz
DAC glitch impulse	$V_{REF} = 0V$ to $10V$ , Data = 7FFh to 800h to 7FFh		10		nV-s
Feedthrough error $V_{OUT}/V_{REF}$	Data = 000h, $V_{REF} = 100\text{kHz}$		-70		dB
Digital feedthrough			2		nV-s
Total harmonic distortion			-105		dB
Output spot noise voltage			25		nV/ $\sqrt{\text{Hz}}$

(1) Specified by design and characterization; not production tested.

**TIMING INFORMATION**

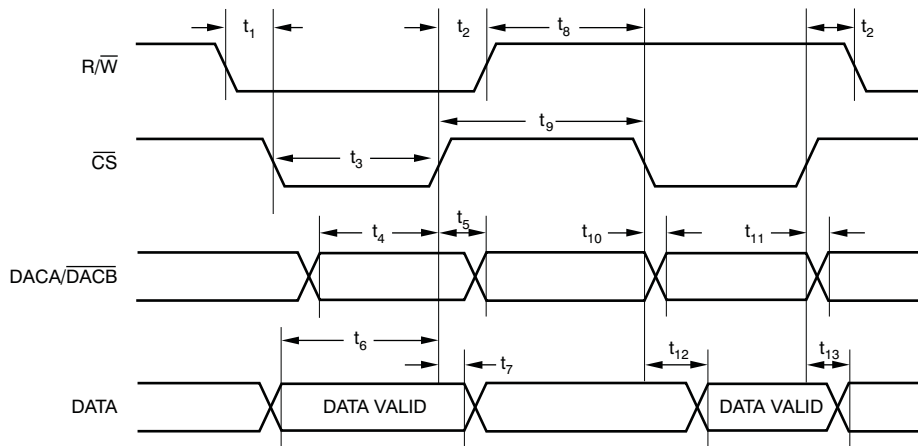

**TIMING REQUIREMENTS: 2.5V to 5.5V**

At  $t_r = t_f = 1\text{ns}$  (10% to 90% of  $V_{DD}$ ) and timed from a voltage level of  $(V_{IL} + V_{IH})/2$ ;  $V_{DD} = 2.5\text{V to }5.5\text{V}$ ,  $V_{REF} = 10\text{V}$ ,  $I_{OUT2} = 0\text{V}$ . All specifications  $-40^\circ\text{C to }+125^\circ\text{C}$ , unless otherwise noted.

PARAMETER <sup>(1)</sup>	TEST CONDITIONS	DAC7822			UNIT
		MIN	TYP	MAX	
$t_1$	R/W to CS setup time	0			ns
$t_2$	R/W to CS hold time	0			ns
$t_3$	CS low time (write cycle)	10			ns
$t_4$	Address setup time	10			ns
$t_5$	Address hold time	0			ns
$t_6$	Data setup time	6			ns
$t_7$	Data hold time	0			ns
$t_8$	R/W high to CS low	5			ns
$t_9$	CS minimum high time	7			ns
$t_{10}$	Address setup time (Read Cycle)	0			ns
$t_{11}$	Address hold time (Read Cycle)	0			ns
$t_{12}$	Data access time		5	35	ns
$t_{13}$	Bus relinquish time		5	10	ns

(1) Ensured by design; not production tested.

**DEVICE INFORMATION**

**RTA PACKAGE  
QFN-40  
(TOP VIEW)**

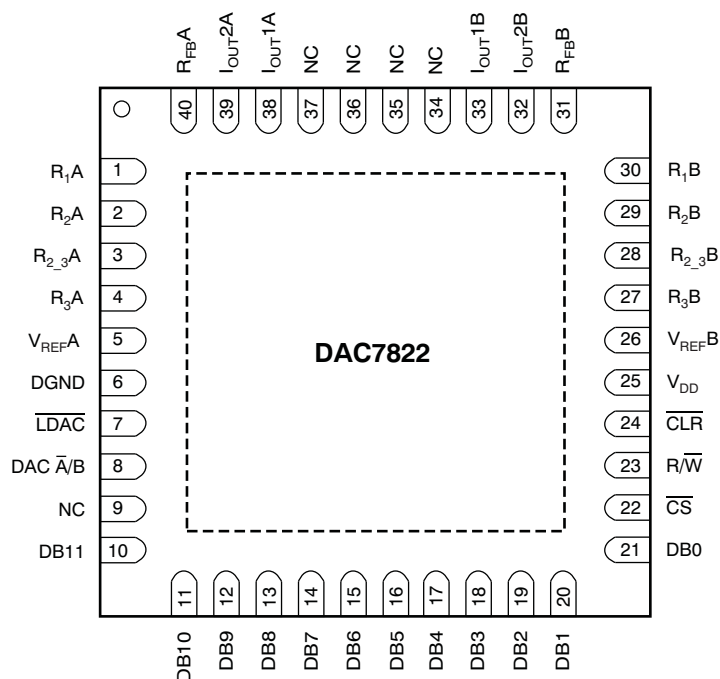

**TERMINAL FUNCTIONS**

PIN NO.	PIN NAME	DESCRIPTION
1-4	R <sub>1</sub> A, R <sub>2</sub> A, R <sub>2_3</sub> A, R <sub>3</sub> A	DAC A 4-Quadrant Resistors. Allows a number of configuration modes, including bipolar operation with minimum of external components.
5, 26	V <sub>REF</sub> A, V <sub>REF</sub> B	DAC Reference Voltage Input Terminals.
6	DGND	Digital Ground Pin.
7	$\overline{\text{LDAC}}$	Load DAC Input. Allows asynchronous or synchronous updates to the DAC output. The DAC is asynchronously updated when this signal goes low. Alternatively, if this line is held permanently low, an automatic or synchronous update mode is selected whereby the DAC is updated on the rising edge of $\overline{\text{CS}}$ .
8	DAC $\overline{\text{A/B}}$	Selects DAC A or B. Low selects DAC A, and high selects DAC B.
9, 34-37	NC	Not internally connected.
10-21	DB11 to DB0	Parallel Data Bits 11 through 0.
22	$\overline{\text{CS}}$	Chip Select Input; active low. Used in conjunction with R/ $\overline{\text{W}}$ to load parallel data to the input latch or to read data from the DAC register. Edge sensitive; when pulled high, the DAC data is latched.
23	R/ $\overline{\text{W}}$	Read/Write. When low, used in conjunction with $\overline{\text{CS}}$ to load parallel data. When high, used in conjunction with $\overline{\text{CS}}$ to read back contents of DAC register.
24	$\overline{\text{CLR}}$	Active Low Control Input. Clears DAC output and input and DAC registers.
25	V <sub>DD</sub>	Positive Power Supply Input. These parts can be operated from a supply of 2.5V to 5.5V.
27-30	R <sub>3</sub> B, R <sub>2_3</sub> B, R <sub>2</sub> B, R <sub>1</sub> B	DAC B 4-Quadrant Resistors. Allow a number of configuration modes, including bipolar operation with a minimum of external components.
31, 40	R <sub>FB</sub> B, R <sub>FB</sub> A	External Amplifier Output.
32	I <sub>OUT</sub> 2B	DAC A Analog Ground. This pin typically should be tied to the analog ground of the system, but can be biased to achieve single-supply operation.
33	I <sub>OUT</sub> 1B	DAC B Current Output.
38	I <sub>OUT</sub> 1A	DAC A Current Output.
39	I <sub>OUT</sub> 2A	DAC A Analog Ground. This pin typically should be tied to the analog ground of the system, but can be biased to achieve single-supply operation.

**TYPICAL CHARACTERISTICS:  $V_{DD} = +5V$**

At  $T_A = +25^\circ C$ ,  $+V_{DD} = +5V$ , unless otherwise noted.

**Channel A**

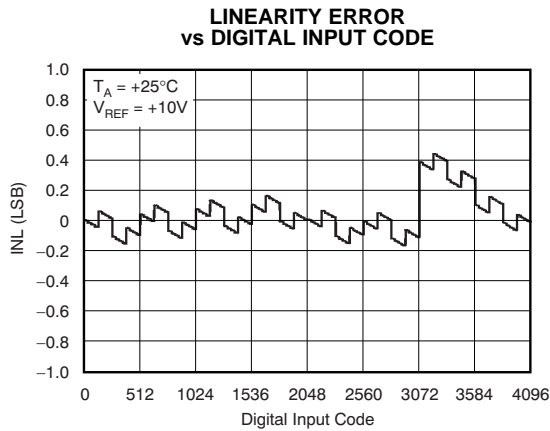

**Figure 1.**

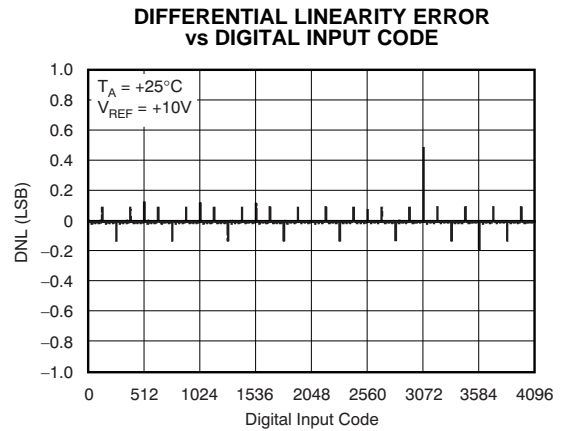

**Figure 2.**

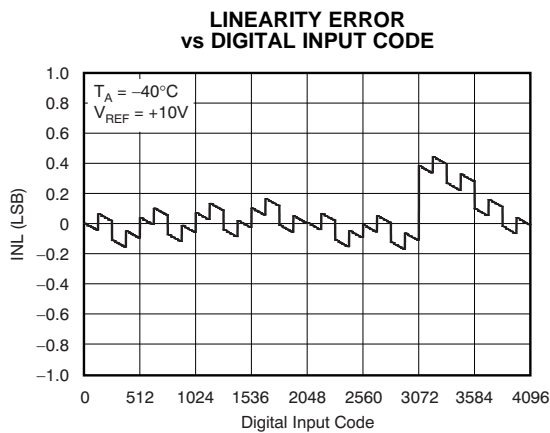

**Figure 3.**

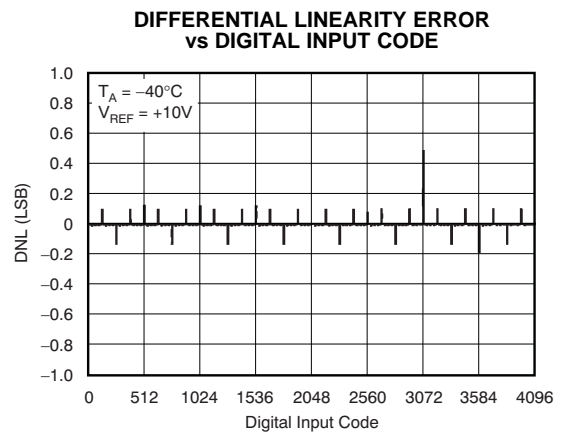

**Figure 4.**

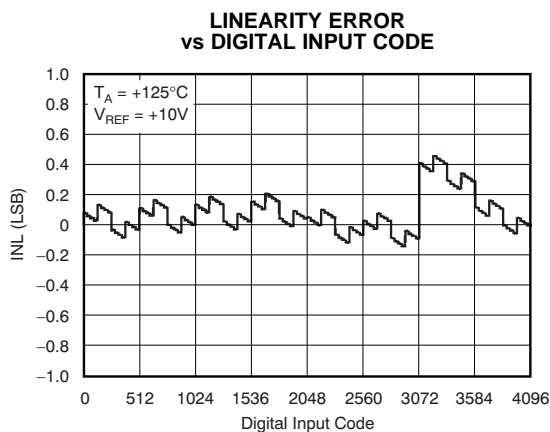

**Figure 5.**

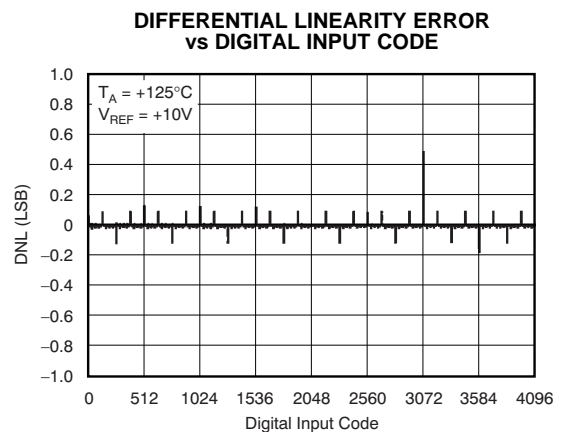
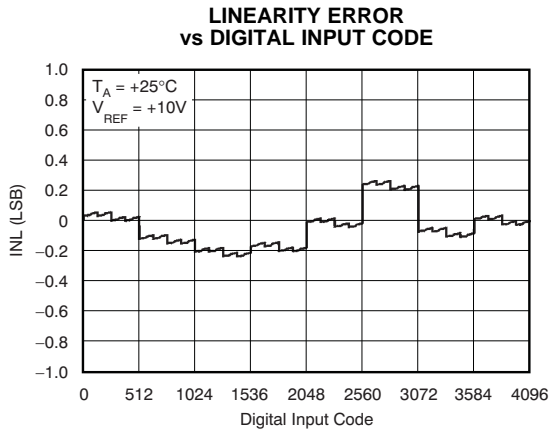

**Figure 6.**

**TYPICAL CHARACTERISTICS:  $V_{DD} = +5V$  (continued)**

At  $T_A = +25^\circ C$ ,  $+V_{DD} = +5V$ , unless otherwise noted.

**Channel B**



**Figure 7.**

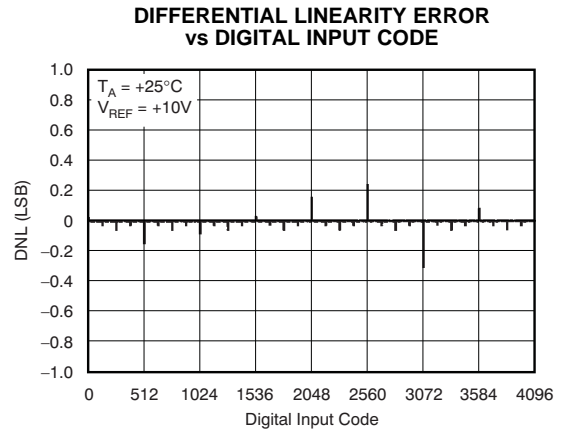

**Figure 8.**

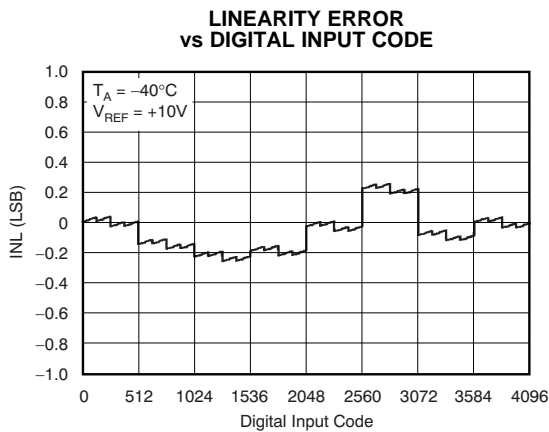

**Figure 9.**

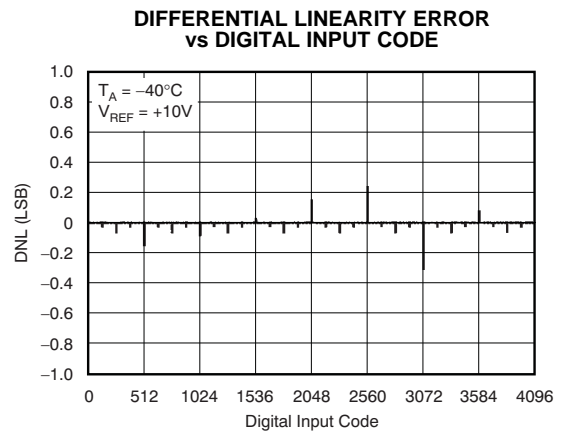

**Figure 10.**

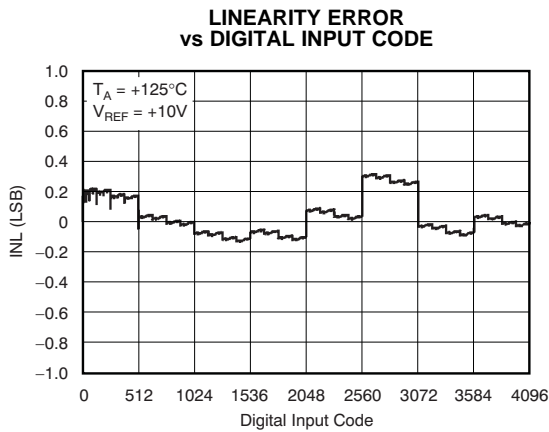

**Figure 11.**

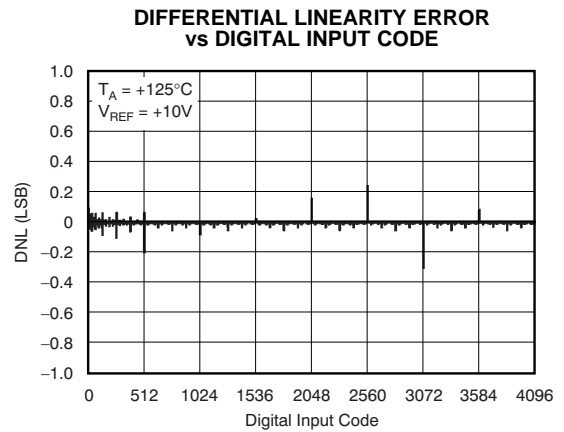

**Figure 12.**

**TYPICAL CHARACTERISTICS:  $V_{DD} = +5V$  (continued)**

At  $T_A = +25^\circ C$ ,  $+V_{DD} = +5V$ , unless otherwise noted.

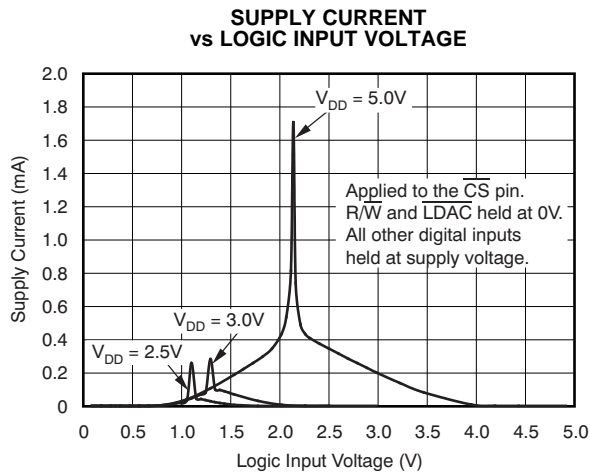

Figure 13.

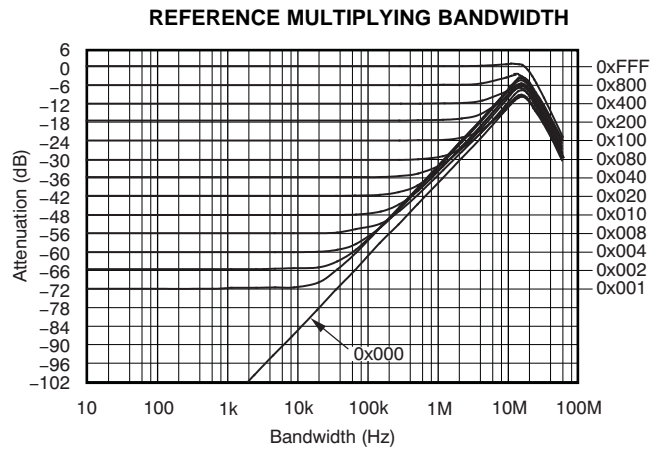

Figure 14.

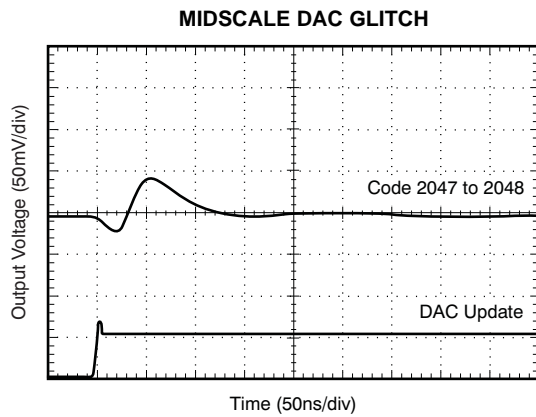

Figure 15.

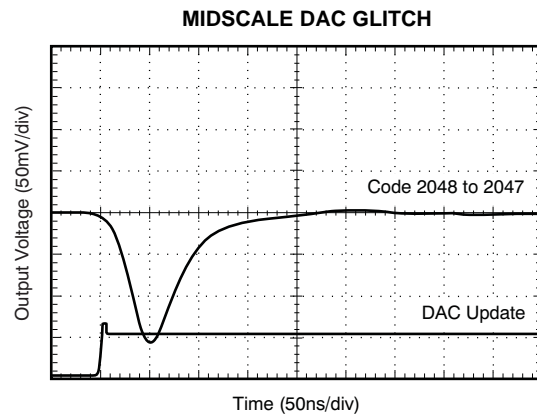

Figure 16.

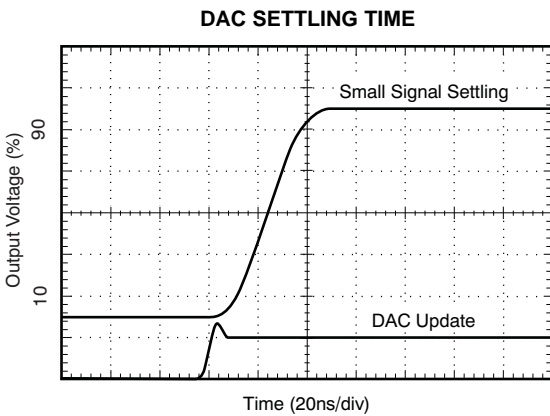

Figure 17.

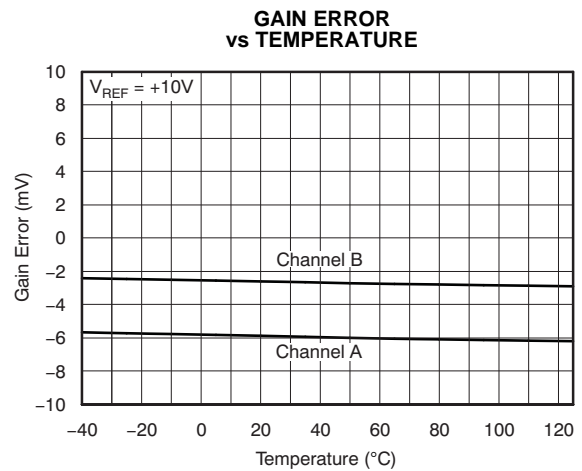
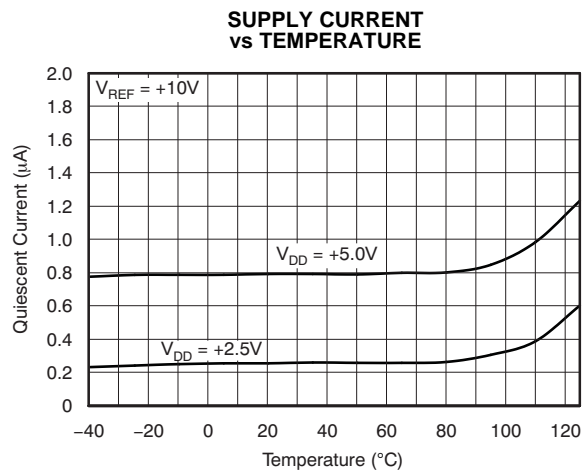

Figure 18.

**TYPICAL CHARACTERISTICS:  $V_{DD} = +5V$  (continued)**

At  $T_A = +25^\circ C$ ,  $+V_{DD} = +5V$ , unless otherwise noted.



**Figure 19.**

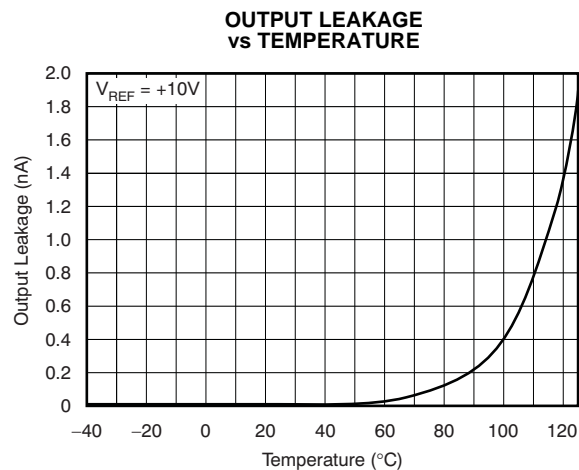

**Figure 20.**

**TYPICAL CHARACTERISTICS:  $V_{DD} = +2.5V$**

At  $T_A = +25^\circ C$ ,  $+V_{DD} = +2.5V$ , unless otherwise noted.

**Channel A**

**LINEARITY ERROR  
vs DIGITAL INPUT CODE**

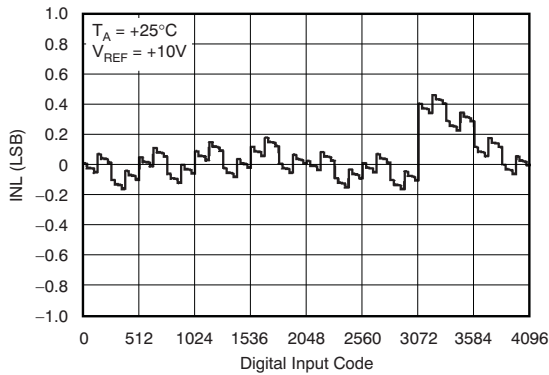

**Figure 21.**

**DIFFERENTIAL LINEARITY ERROR  
vs DIGITAL INPUT CODE**

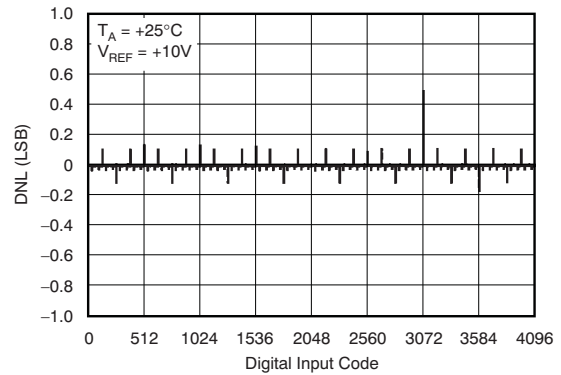

**Figure 22.**

**LINEARITY ERROR  
vs DIGITAL INPUT CODE**

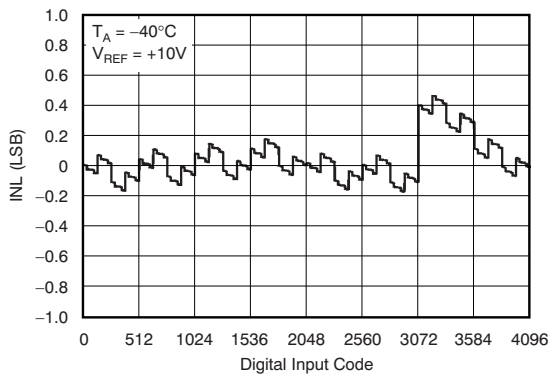

**Figure 23.**

**DIFFERENTIAL LINEARITY ERROR  
vs DIGITAL INPUT CODE**

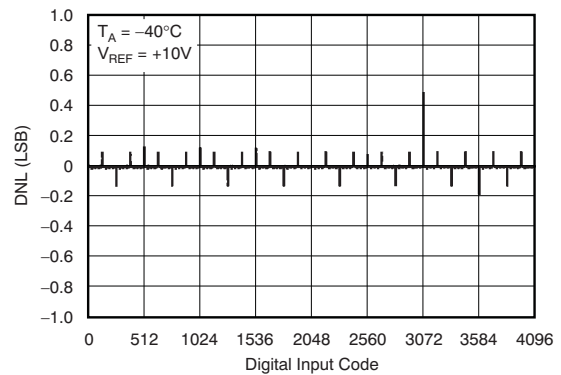

**Figure 24.**

**LINEARITY ERROR  
vs DIGITAL INPUT CODE**

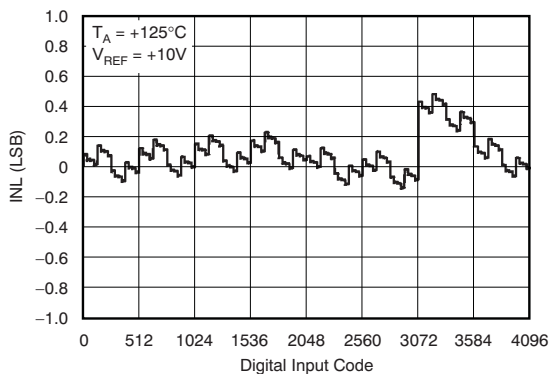

**Figure 25.**

**DIFFERENTIAL LINEARITY ERROR  
vs DIGITAL INPUT CODE**

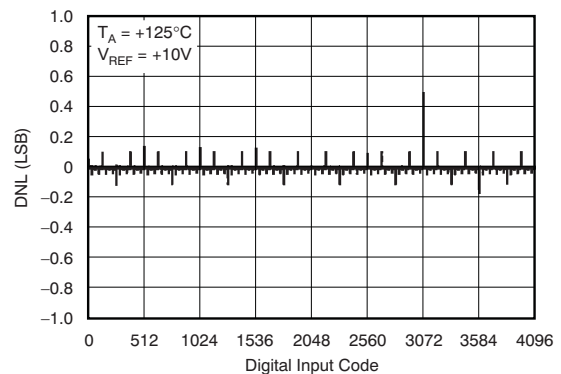

**Figure 26.**

**TYPICAL CHARACTERISTICS:  $V_{DD} = +2.5V$  (continued)**

At  $T_A = +25^\circ C$ ,  $+V_{DD} = +2.5V$ , unless otherwise noted.

**Channel B**

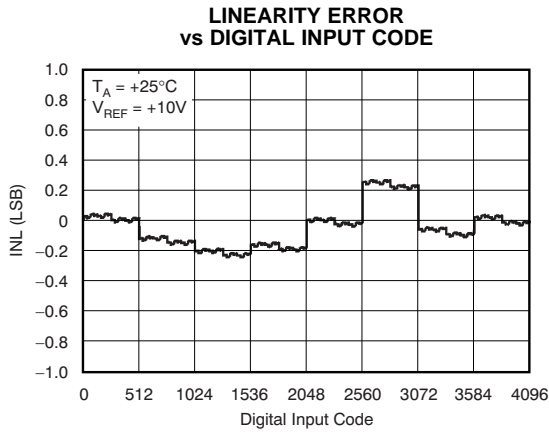

Figure 27.

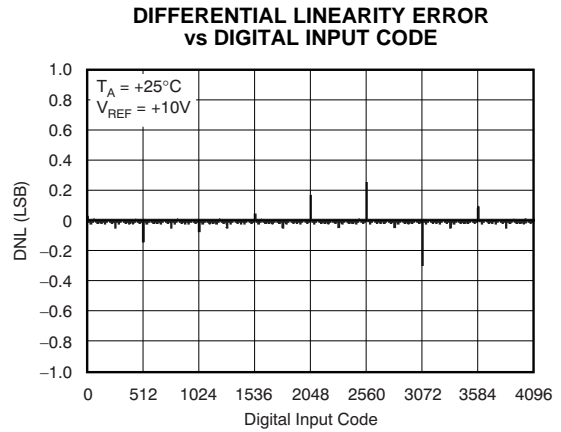

Figure 28.

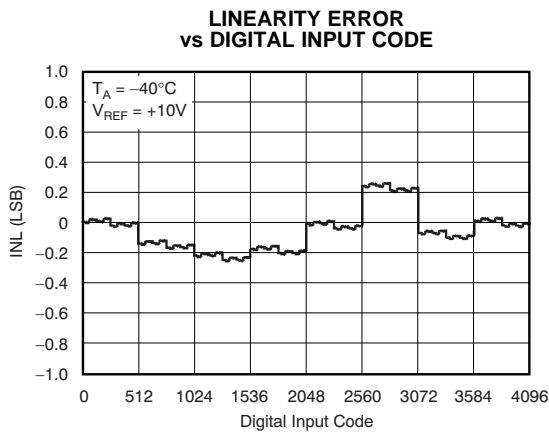

Figure 29.

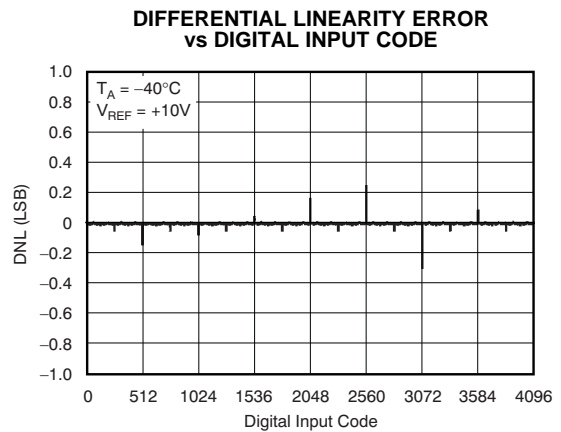

Figure 30.

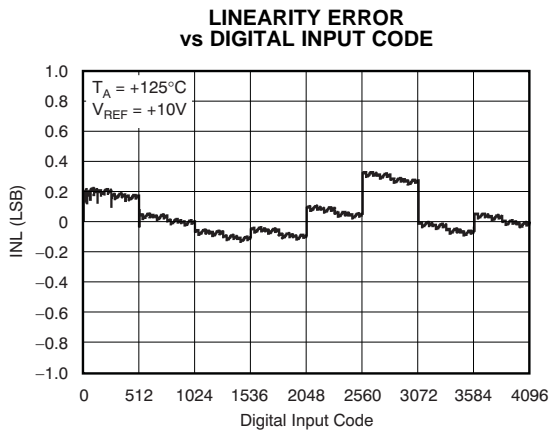

Figure 31.

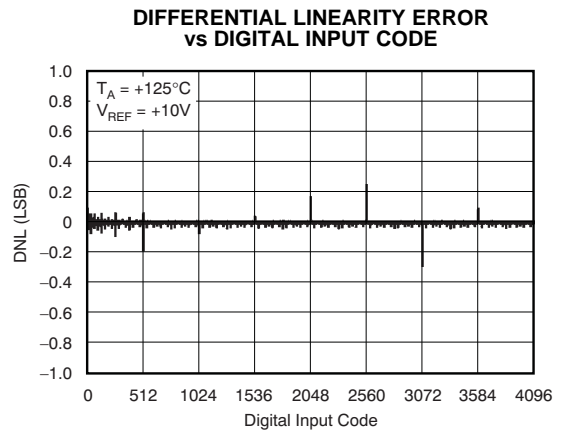
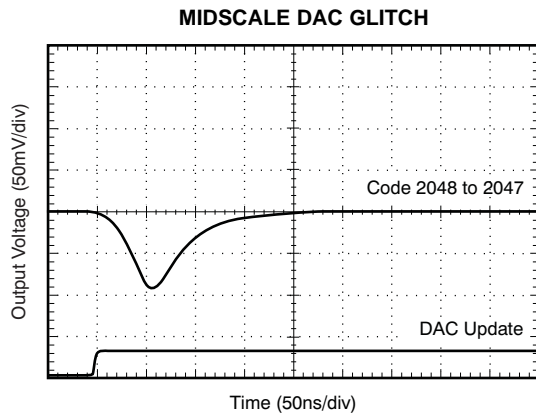

Figure 32.

**TYPICAL CHARACTERISTICS:  $V_{DD} = +2.5V$  (continued)**

At  $T_A = +25^\circ C$ ,  $+V_{DD} = +2.5V$ , unless otherwise noted.



**Figure 33.**

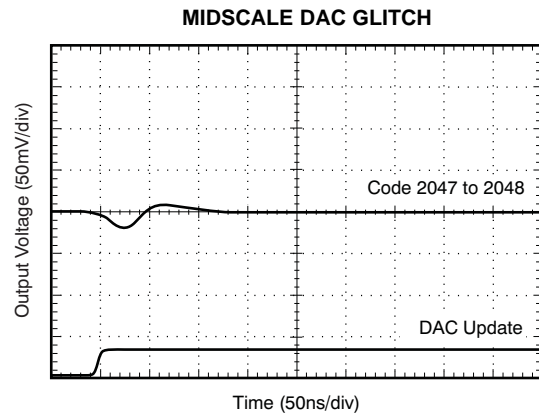

**Figure 34.**

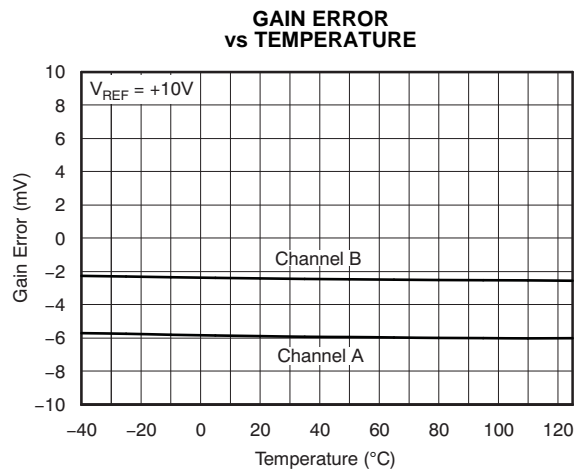

**Figure 35.**

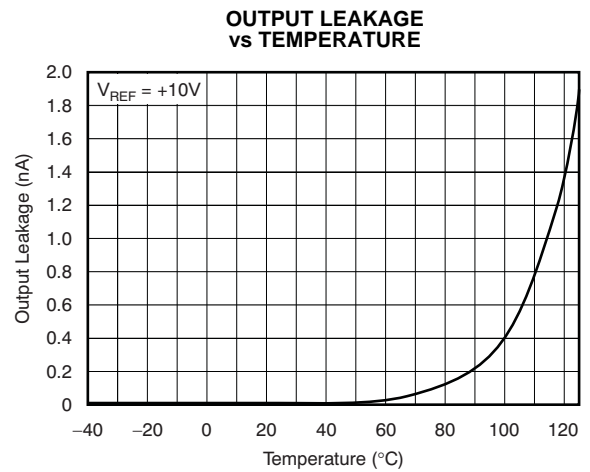

**Figure 36.**

## THEORY OF OPERATION

The DAC7822 is a dual channel, current output, 12-bit, digital-to-analog converter (DAC). The architecture, illustrated in Figure 37, is an R-2R ladder configuration with the three MSBs segmented. Each 2R leg of the ladder is either switched to I<sub>OUT1</sub> or the I<sub>OUT2</sub> terminal. The I<sub>OUT1</sub> terminal of the DAC is held at a virtual GND potential by the use of an external I/V converter op amp. The R-2R ladder is connected to an external reference input V<sub>REF</sub> that determines the DAC full-scale current. The R-2R ladder presents a code-independent load impedance to the external reference of 10kΩ ±20%. The external reference voltage can vary over a range of –15V to +15V, thus providing bipolar I<sub>OUT</sub> current operation. By using an external I/V converter and the DAC7822 R<sub>FB</sub> resistor, output voltage ranges of –V<sub>REF</sub> to V<sub>REF</sub> can be generated.

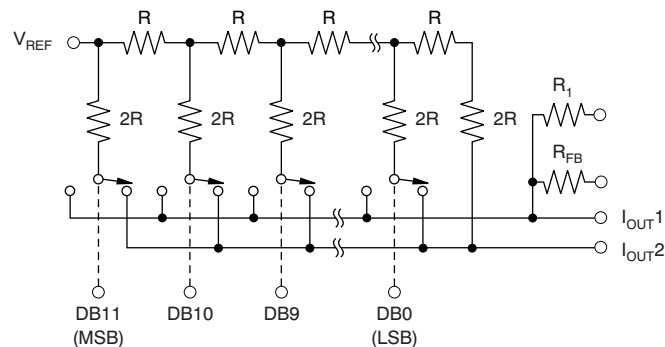

Figure 37. Equivalent R-2R DAC Circuit

When using an external I/V converter and the DAC7822 R<sub>FB</sub> and R<sub>1</sub> resistors, the DAC output voltage is given by Equation 1:

$$V_{OUT} = -V_{REF} \times \frac{CODE}{4096} \quad (1)$$

Each DAC code determines the 2R leg switch position to either GND or I<sub>OUT</sub>. Because the DAC output impedance as seen looking into the I<sub>OUT1</sub> terminal changes versus code, the external I/V converter noise gain also changes. Because of this, the external I/V converter op amp must have a sufficiently low offset voltage such that the amplifier offset is not modulated by the DAC I<sub>OUT1</sub> terminal impedance change. External op amps with large offset voltages can produce INL errors in the transfer function of the DAC7822 as a result of offset modulation versus DAC code.

For best linearity performance of the DAC7822, a low input offset voltage op amp (such as the OPA277) is recommended (see Figure 38). This circuit allows V<sub>REF</sub> swinging from –10V to +10V.

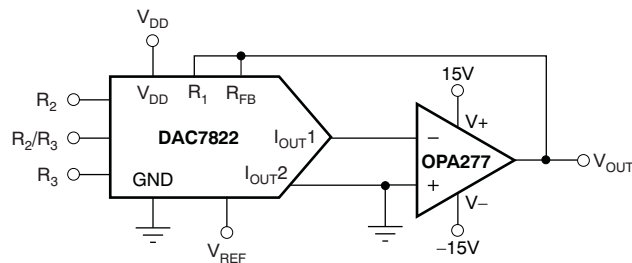

Figure 38. Voltage Output Configuration

APPLICATION INFORMATION

Stability Circuit

For a current-to-voltage design (see Figure 39), the DAC7822 current output ( $I_{OUT}$ ) and the connection with the inverting node of the op amp should be as short as possible and according to correct printed circuit board (PCB) layout design practices. For each code change, there is a step function. If the gain bandwidth product (GBP) of the op amp is limited and parasitic capacitance is excessive at the inverting node, then gain peaking is possible. Therefore, for circuit stability, a compensation capacitor  $C_1$  (1pF to 5pF typ) can be added to the design, as shown in Figure 39.

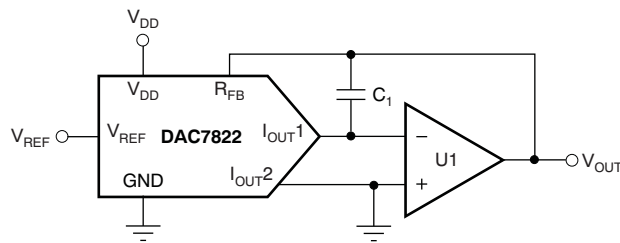

Figure 39. Gain Peaking Prevention Circuit with Compensation Capacitor

Amplifier Selection

There are many choices and many differences in selecting the proper operational amplifier for a multiplying DAC (MDAC). Making the analog signal out of the MDAC is one critical aspect. However, there are also other issues to take into account such as amplifier noise, input bias current, and offset voltage, as well as MDAC resolution and glitch energy. Table 1 and Table 2 suggest some suitable operational amplifiers for low power, fast settling, and high-speed applications. A greater selection of operational amplifiers can be found at [www.ti.com/amplifier](http://www.ti.com/amplifier).

Table 1. Suitable Precision Operational Amplifiers from Texas Instruments

PRODUCT	TOTAL SUPPLY VOLTAGE (V) (min)	TOTAL SUPPLY VOLTAGE (V) (max)	$I_O$ PER CHANNEL (max) (mA)	GBW (typ) (MHz)	SLEW RATE (typ) (V/ $\mu$ s)	OFFSET DRIFT (typ) ( $\mu$ V/ $^{\circ}$ C)	$I_{IB}$ (max) (pA)	CMRR (min) (dB)	PACKAGE/ LEAD	DESCRIPTION
<b>Low Power</b>										
OPA703	4	12	0.2	1	0.6	4	10	70	SOT5-23, PDIP-8, SOIC-8	12V, CMOS, Rail-to-Rail I/O, Operational Amplifier
OPA735	2.7	12	0.75	1.6	1.5	0.01	200	115	SOT5-23, SOIC-8	0.05 $\mu$ V/ $^{\circ}$ C (max), Single-Supply CMOS Zero-Drift Series Operational Amplifier
OPA344	2.7	5.5	0.25	1	1	2.5	10	80	SOT5-23, PDIP-8, SOIC-8	Low Power, Single-Supply, Rail-To-Rail Operational Amplifiers MicroAmplifier Series
OPA348	2.1	5.5	0.065	1	0.5	2	10	70	SC5-70, SOT5-23, SOIC-8	1MHz, 45 $\mu$ A, Rail-to-Rail I/O, Single Op Amp
OPA277	4	36	0.825	1	0.8	0.1	1000	130	PDIP-8, SOIC-8, SON-8	High Precision Operational Amplifiers
<b>Fast Settling</b>										
OPA350	2.7	5.5	7.5	38	22	4	10	76	MSOP-8, PDIP-8, SOIC-8	High-Speed, Single-Supply, Rail-to-Rail Operational Amplifiers MicroAmplifier Series
OPA727	4	12	6.5	20	30	0.6	500	86	MSOP-8, SON-8	e-trim 20MHz, High Precision CMOS Operational Amplifier
OPA227	5	36	3.8	8	2.3	0.1	10000	120	PDIP-8, SOIC-8	High Precision, Low Noise Operational Amplifiers

**Table 2. Suitable High Speed Operational Amplifiers from Texas Instruments (Multiple Channel Options)**

PRODUCT	SUPPLY VOLTAGE (V)	GBW PRODUCT (MHz)	VOLTAGE NOISE nV/√Hz	GBW (typ) (MHz)	SLEW RATE (V/μs)	V <sub>os</sub> (typ) (μV)	V <sub>os</sub> (max) (μV)	CMRR (min) (dB)	PACKAGE/ LEAD	DESCRIPTION
<b>Single Channel</b>										
THS4281	±2.7 to ±15	38	12.5	35	500	3500	500	1000	SOT5-23, MSOP-8, SOIC-8	Very Low-Power High Speed Rail-To-Rail Input/Output Voltage Feedback Operational Amplifier
THS4031	±4.5 to ±16.5	200	1.6	100	500	3000	3000	8000	CDIP-8, MSOP-8, SOIC-8	100-MHz Low Noise Voltage-Feedback Amplifier
THS4631	±4.5 to ±16.5	210	7	900	260	2000	50pA	2	SOIC-8, MSOP-8	High Speed FET-Input Operational Amplifier
OPA656	±4 to ±6	230	7	290	250	2600	2pA	5pA	SOIC-8, SOT5-23	Wideband, Unity Gain Stable FET-Input Operational Amplifier
OPA820	±2.5 to ±6	280	2.5	240	200	1200	900	23,000	SOIC-8, SOT5-23	Unity Gain Stable, Low Noise, Voltage Feedback Operational Amplifier
<b>Dual Channel</b>										
THS4032	±4.5 to ±16.5	200	1.6	100	500	3000	3000	8000	SOIC-8, MSOP-8	100-MHz Low Noise Voltage-Feedback Amplifier, Dual
OPA2822	±2 to ±6.3	220	2	170	200	1200	9600	12000	SOIC-8, MSOP-8	SpeedPlus Dual Wideband, Low-Noise Operational Amplifier

### Positive Voltage Output Circuit

As Figure 40 illustrates, in order to generate a positive voltage output, a negative reference is input to the DAC7822. This design is suggested instead of using an inverting amp to invert the output as a result of resistor tolerance errors. For a negative reference, V<sub>OUT</sub> and GND of the reference are level-shifted to a virtual ground and a –2.5V input to the DAC7822 with an op amp.

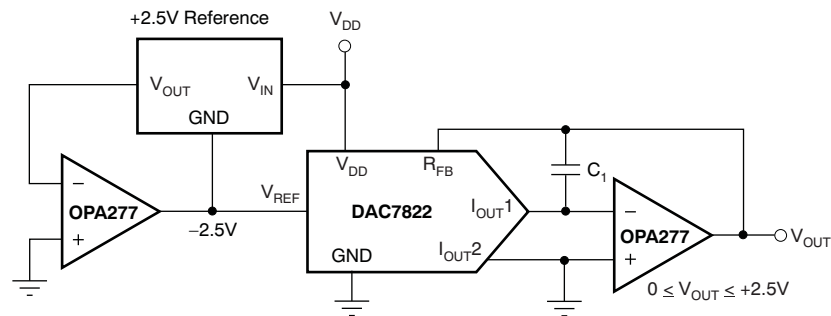

**Figure 40. Positive Voltage Output Circuit**

### Bipolar Output Section

The DAC7822, as a 2-quadrant multiplying DAC, can be used to generate a unipolar output. The polarity of the full-scale output I<sub>OUT</sub> is the inverse of the input reference voltage at V<sub>REF</sub>.

Some applications require full 4-quadrant multiplying capabilities or bipolar output swing. As shown in Figure 41, external op amp U2 is added as a summing amp and has a gain of 2X that widens the output span to 5V. A 4-quadrant multiplying circuit is implemented by using a 2.5V offset of the reference voltage to bias U2. According to the circuit transfer equation given in Equation 2, input data (D) from code 0 to full-scale produce output voltages of V<sub>OUT</sub> = –2.5V to V<sub>OUT</sub> = +2.5V.

$$V_{OUT} = \left( \frac{D}{0.5 \times 2^N} - 1 \right) \times V_{REF} \quad (2)$$

External resistance mismatching is the significant error in [Figure 41](#).

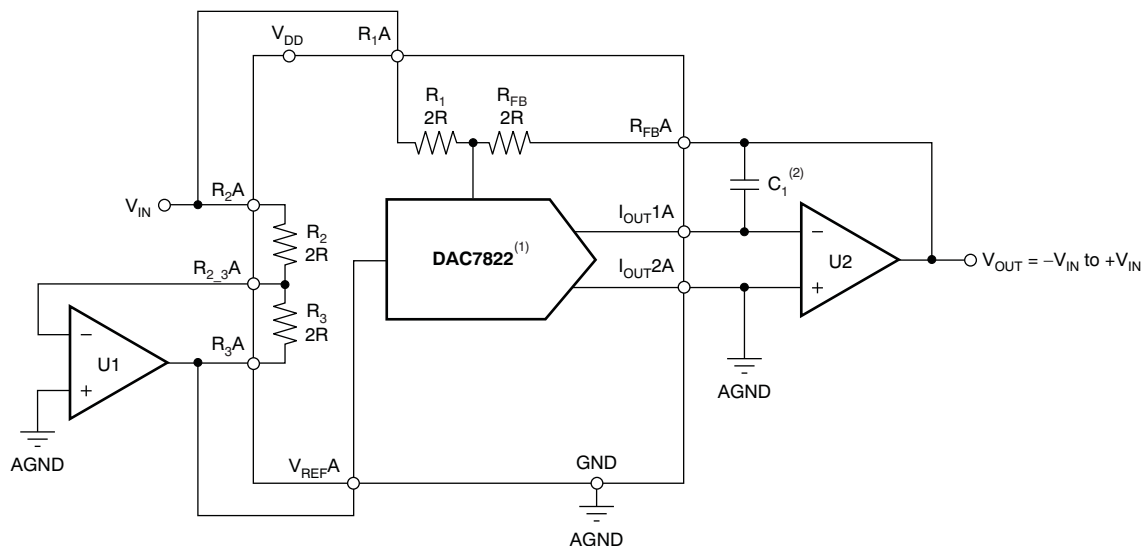

NOTES: (1) Similar configuration for DAC B.  
 (2)  $C_1$  phase compensation (1pF to 5pF) may be required if U2 is a high-speed amplifier.

**Figure 41. Bipolar Output Circuit**

### Parallel Interface

Data are loaded to the DAC7822 as a 12-bit parallel word. The bi-directional bus is controlled with  $\overline{CS}$  and  $R/\overline{W}$ , allowing data to be written to or read from the DAC register. To write to the device,  $\overline{CS}$  and  $R/\overline{W}$  are brought low, and data available on the data lines fills the input register. The rising edge of  $\overline{CS}$  latches the data and transfers the latched data-word to the DAC register. The DAC latches are not transparent; therefore, a write sequence must consist of a falling and rising edge on  $\overline{CS}$  in order to ensure that data are loaded to the DAC register and its analog equivalent is reflected on the DAC output.

To read data stored in the device,  $R/\overline{W}$  is held high and  $\overline{CS}$  is brought low. Data are loaded from the DAC register back to the input register and out onto the data line, where it can be read back to the controller.

### Cross-Reference

The DAC7822 has an industry-standard pinout. [Table 3](#) provides the cross-reference information.

**Table 3. Cross-Reference**

PRODUCT	INL (LSB)	DNL (LSB)	SPECIFIED TEMPERATURE RANGE	PACKAGE DESCRIPTION	PACKAGE OPTION	CROSS-REFERENCE PART
DAC7822	$\pm 1$	$\pm 1$	-40°C to +125°C	40-Lead QFN	QFN-40	AD5405

## PACKAGING INFORMATION

Orderable Device	Status (1)	Package Type	Package Drawing	Pins	Package Qty	Eco Plan (2)	Lead/Ball Finish	MSL Peak Temp (3)	Op Temp (°C)	Top-Side Markings (4)	Samples
DAC7822IRTAR	ACTIVE	WQFN	RTA	40	2000	Green (RoHS & no Sb/Br)	CU NIPDAU	Level-2-260C-1 YEAR	-40 to 125	DAC7822	<a href="#">Samples</a>
DAC7822IRTARG4	ACTIVE	WQFN	RTA	40	2000	Green (RoHS & no Sb/Br)	CU NIPDAU	Level-2-260C-1 YEAR	-40 to 125	DAC7822	<a href="#">Samples</a>
DAC7822IRTAT	ACTIVE	WQFN	RTA	40	250	Green (RoHS & no Sb/Br)	CU NIPDAU	Level-2-260C-1 YEAR	-40 to 125	DAC7822	<a href="#">Samples</a>
DAC7822IRTATG4	ACTIVE	WQFN	RTA	40	250	Green (RoHS & no Sb/Br)	CU NIPDAU	Level-2-260C-1 YEAR	-40 to 125	DAC7822	<a href="#">Samples</a>

(1) The marketing status values are defined as follows:

**ACTIVE:** Product device recommended for new designs.

**LIFEBUY:** TI has announced that the device will be discontinued, and a lifetime-buy period is in effect.

**NRND:** Not recommended for new designs. Device is in production to support existing customers, but TI does not recommend using this part in a new design.

**PREVIEW:** Device has been announced but is not in production. Samples may or may not be available.

**OBSOLETE:** TI has discontinued the production of the device.

(2) Eco Plan - The planned eco-friendly classification: Pb-Free (RoHS), Pb-Free (RoHS Exempt), or Green (RoHS & no Sb/Br) - please check <http://www.ti.com/productcontent> for the latest availability information and additional product content details.

**TBD:** The Pb-Free/Green conversion plan has not been defined.

**Pb-Free (RoHS):** TI's terms "Lead-Free" or "Pb-Free" mean semiconductor products that are compatible with the current RoHS requirements for all 6 substances, including the requirement that lead not exceed 0.1% by weight in homogeneous materials. Where designed to be soldered at high temperatures, TI Pb-Free products are suitable for use in specified lead-free processes.

**Pb-Free (RoHS Exempt):** This component has a RoHS exemption for either 1) lead-based flip-chip solder bumps used between the die and package, or 2) lead-based die adhesive used between the die and leadframe. The component is otherwise considered Pb-Free (RoHS compatible) as defined above.

**Green (RoHS & no Sb/Br):** TI defines "Green" to mean Pb-Free (RoHS compatible), and free of Bromine (Br) and Antimony (Sb) based flame retardants (Br or Sb do not exceed 0.1% by weight in homogeneous material)

(3) MSL, Peak Temp. -- The Moisture Sensitivity Level rating according to the JEDEC industry standard classifications, and peak solder temperature.

(4) Multiple Top-Side Markings will be inside parentheses. Only one Top-Side Marking contained in parentheses and separated by a "~" will appear on a device. If a line is indented then it is a continuation of the previous line and the two combined represent the entire Top-Side Marking for that device.

**Important Information and Disclaimer:** The information provided on this page represents TI's knowledge and belief as of the date that it is provided. TI bases its knowledge and belief on information provided by third parties, and makes no representation or warranty as to the accuracy of such information. Efforts are underway to better integrate information from third parties. TI has taken and continues to take reasonable steps to provide representative and accurate information but may not have conducted destructive testing or chemical analysis on incoming materials and chemicals. TI and TI suppliers consider certain information to be proprietary, and thus CAS numbers and other limited information may not be available for release.

In no event shall TI's liability arising out of such information exceed the total purchase price of the TI part(s) at issue in this document sold by TI to Customer on an annual basis.



**TAPE AND REEL INFORMATION**

**QUADRANT ASSIGNMENTS FOR PIN 1 ORIENTATION IN TAPE**

\*All dimensions are nominal

Device	Package Type	Package Drawing	Pins	SPQ	Reel Diameter (mm)	Reel Width W1 (mm)	A0 (mm)	B0 (mm)	K0 (mm)	P1 (mm)	W (mm)	Pin1 Quadrant
DAC7822IRTAR	WQFN	RTA	40	2000	330.0	16.4	6.3	6.3	1.5	12.0	16.0	Q2
DAC7822IRTAT	WQFN	RTA	40	250	180.0	16.4	6.3	6.3	1.5	12.0	16.0	Q2

**TAPE AND REEL BOX DIMENSIONS**



\*All dimensions are nominal

Device	Package Type	Package Drawing	Pins	SPQ	Length (mm)	Width (mm)	Height (mm)
DAC7822IRTAR	WQFN	RTA	40	2000	336.6	336.6	28.6
DAC7822IRTAT	WQFN	RTA	40	250	213.0	191.0	55.0

RTA (S-PQFP-N40)

PLASTIC QUAD FLATPACK

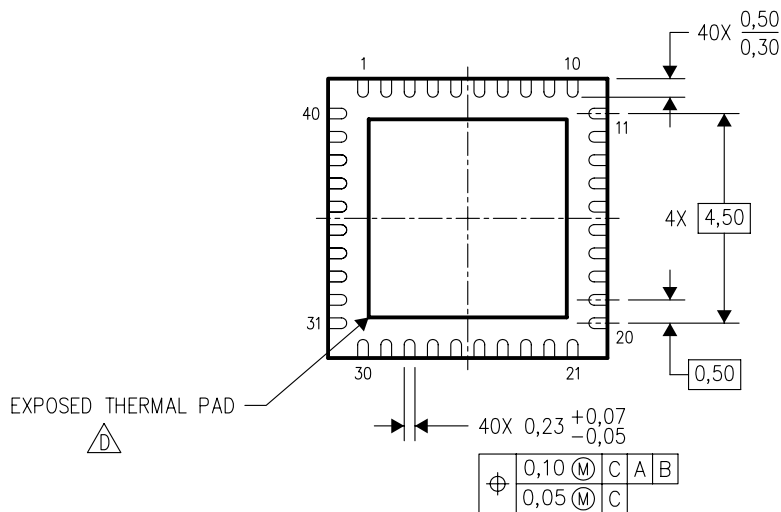
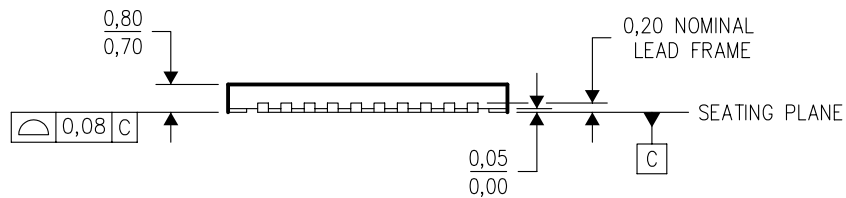
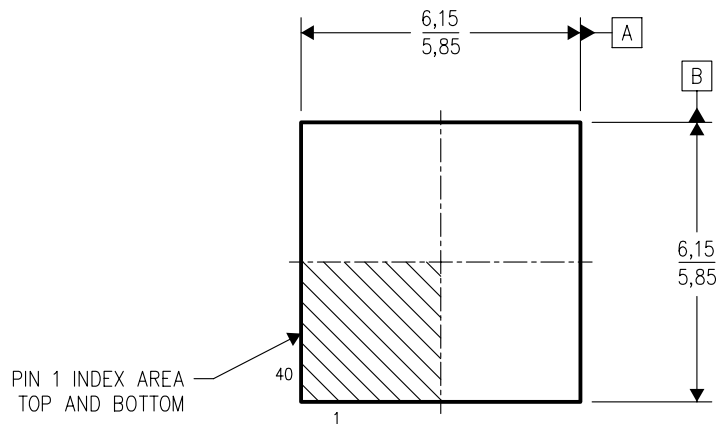

4204422/B 11/04

- NOTES:
- A. All linear dimensions are in millimeters. Dimensioning and tolerancing per ASME Y14.5M-1994.
  - B. This drawing is subject to change without notice.
  - C. QFN (Quad Flatpack No-Lead) Package configuration.
  -  The package thermal pad must be soldered to the board for thermal and mechanical performance. See the Product Data Sheet for details regarding the exposed thermal pad dimensions.

## THERMAL PAD MECHANICAL DATA

RTA (S-PWQFN-N40)

PLASTIC QUAD FLATPACK NO-LEAD

### THERMAL INFORMATION

This package incorporates an exposed thermal pad that is designed to be attached directly to an external heatsink. The thermal pad must be soldered directly to the printed circuit board (PCB). After soldering, the PCB can be used as a heatsink. In addition, through the use of thermal vias, the thermal pad can be attached directly to the appropriate copper plane shown in the electrical schematic for the device, or alternatively, can be attached to a special heatsink structure designed into the PCB. This design optimizes the heat transfer from the integrated circuit (IC).

For information on the Quad Flatpack No-Lead (QFN) package and its advantages, refer to Application Report, QFN/SON PCB Attachment, Texas Instruments Literature No. SLUA271. This document is available at [www.ti.com](http://www.ti.com).

The exposed thermal pad dimensions for this package are shown in the following illustration.

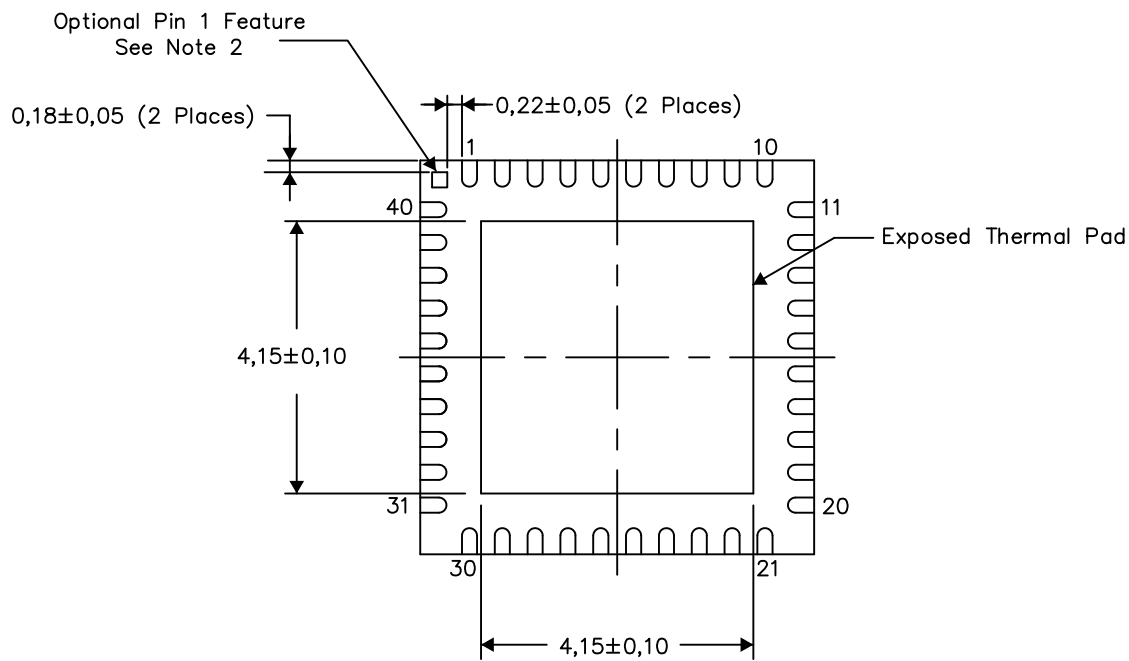

Bottom View

Exposed Thermal Pad Dimensions

4206335-2/F 04/14

#### NOTES:

- 1) All linear dimensions are in millimeters
- 2) The Pin 1 Identification mark is an optional feature that may be present on some devices  
In addition, this Pin 1 feature if present is electrically connected to the center thermal pad and therefore should be considered when routing the board layout.

RTA (S-PWQFN-N40)

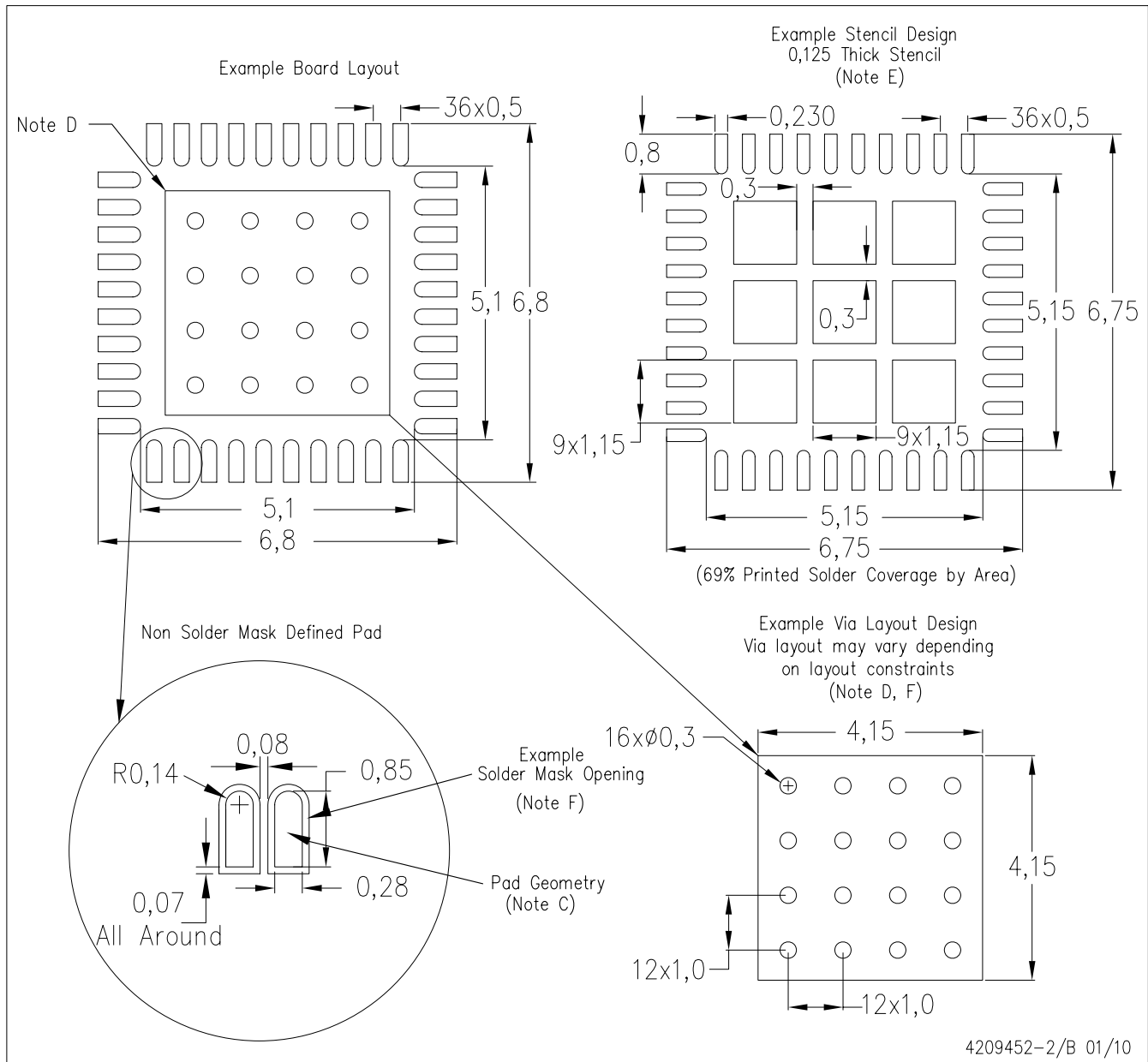

- NOTES:
- A. All linear dimensions are in millimeters.
  - B. This drawing is subject to change without notice.
  - C. Publication IPC-7351 is recommended for alternate designs.
  - D. This package is designed to be soldered to a thermal pad on the board. Refer to Application Note, Quad Flat-Pack Packages, Texas Instruments Literature No. SCBA017, SLUA271, and also the Product Data Sheets for specific thermal information, via requirements, and recommended board layout. These documents are available at [www.ti.com](http://www.ti.com) <<http://www.ti.com>>.
  - E. Laser cutting apertures with trapezoidal walls and also rounding corners will offer better paste release. Customers should contact their board assembly site for stencil design recommendations. Refer to IPC 7525 for stencil design considerations.
  - F. Customers should contact their board fabrication site for recommended solder mask tolerances and via tenting recommendations for vias placed in the thermal pad.

## IMPORTANT NOTICE

Texas Instruments Incorporated and its subsidiaries (TI) reserve the right to make corrections, enhancements, improvements and other changes to its semiconductor products and services per JESD46, latest issue, and to discontinue any product or service per JESD48, latest issue. Buyers should obtain the latest relevant information before placing orders and should verify that such information is current and complete. All semiconductor products (also referred to herein as "components") are sold subject to TI's terms and conditions of sale supplied at the time of order acknowledgment.

TI warrants performance of its components to the specifications applicable at the time of sale, in accordance with the warranty in TI's terms and conditions of sale of semiconductor products. Testing and other quality control techniques are used to the extent TI deems necessary to support this warranty. Except where mandated by applicable law, testing of all parameters of each component is not necessarily performed.

TI assumes no liability for applications assistance or the design of Buyers' products. Buyers are responsible for their products and applications using TI components. To minimize the risks associated with Buyers' products and applications, Buyers should provide adequate design and operating safeguards.

TI does not warrant or represent that any license, either express or implied, is granted under any patent right, copyright, mask work right, or other intellectual property right relating to any combination, machine, or process in which TI components or services are used. Information published by TI regarding third-party products or services does not constitute a license to use such products or services or a warranty or endorsement thereof. Use of such information may require a license from a third party under the patents or other intellectual property of the third party, or a license from TI under the patents or other intellectual property of TI.

Reproduction of significant portions of TI information in TI data books or data sheets is permissible only if reproduction is without alteration and is accompanied by all associated warranties, conditions, limitations, and notices. TI is not responsible or liable for such altered documentation. Information of third parties may be subject to additional restrictions.

Resale of TI components or services with statements different from or beyond the parameters stated by TI for that component or service voids all express and any implied warranties for the associated TI component or service and is an unfair and deceptive business practice. TI is not responsible or liable for any such statements.

Buyer acknowledges and agrees that it is solely responsible for compliance with all legal, regulatory and safety-related requirements concerning its products, and any use of TI components in its applications, notwithstanding any applications-related information or support that may be provided by TI. Buyer represents and agrees that it has all the necessary expertise to create and implement safeguards which anticipate dangerous consequences of failures, monitor failures and their consequences, lessen the likelihood of failures that might cause harm and take appropriate remedial actions. Buyer will fully indemnify TI and its representatives against any damages arising out of the use of any TI components in safety-critical applications.

In some cases, TI components may be promoted specifically to facilitate safety-related applications. With such components, TI's goal is to help enable customers to design and create their own end-product solutions that meet applicable functional safety standards and requirements. Nonetheless, such components are subject to these terms.

No TI components are authorized for use in FDA Class III (or similar life-critical medical equipment) unless authorized officers of the parties have executed a special agreement specifically governing such use.

Only those TI components which TI has specifically designated as military grade or "enhanced plastic" are designed and intended for use in military/aerospace applications or environments. Buyer acknowledges and agrees that any military or aerospace use of TI components which have **not** been so designated is solely at the Buyer's risk, and that Buyer is solely responsible for compliance with all legal and regulatory requirements in connection with such use.

TI has specifically designated certain components as meeting ISO/TS16949 requirements, mainly for automotive use. In any case of use of non-designated products, TI will not be responsible for any failure to meet ISO/TS16949.

### Products

Audio	<a href="http://www.ti.com/audio">www.ti.com/audio</a>
Amplifiers	<a href="http://amplifier.ti.com">amplifier.ti.com</a>
Data Converters	<a href="http://dataconverter.ti.com">dataconverter.ti.com</a>
DLP® Products	<a href="http://www.dlp.com">www.dlp.com</a>
DSP	<a href="http://dsp.ti.com">dsp.ti.com</a>
Clocks and Timers	<a href="http://www.ti.com/clocks">www.ti.com/clocks</a>
Interface	<a href="http://interface.ti.com">interface.ti.com</a>
Logic	<a href="http://logic.ti.com">logic.ti.com</a>
Power Mgmt	<a href="http://power.ti.com">power.ti.com</a>
Microcontrollers	<a href="http://microcontroller.ti.com">microcontroller.ti.com</a>
RFID	<a href="http://www.ti-rfid.com">www.ti-rfid.com</a>
OMAP Applications Processors	<a href="http://www.ti.com/omap">www.ti.com/omap</a>
Wireless Connectivity	<a href="http://www.ti.com/wirelessconnectivity">www.ti.com/wirelessconnectivity</a>

### Applications

Automotive and Transportation	<a href="http://www.ti.com/automotive">www.ti.com/automotive</a>
Communications and Telecom	<a href="http://www.ti.com/communications">www.ti.com/communications</a>
Computers and Peripherals	<a href="http://www.ti.com/computers">www.ti.com/computers</a>
Consumer Electronics	<a href="http://www.ti.com/consumer-apps">www.ti.com/consumer-apps</a>
Energy and Lighting	<a href="http://www.ti.com/energy">www.ti.com/energy</a>
Industrial	<a href="http://www.ti.com/industrial">www.ti.com/industrial</a>
Medical	<a href="http://www.ti.com/medical">www.ti.com/medical</a>
Security	<a href="http://www.ti.com/security">www.ti.com/security</a>
Space, Avionics and Defense	<a href="http://www.ti.com/space-avionics-defense">www.ti.com/space-avionics-defense</a>
Video and Imaging	<a href="http://www.ti.com/video">www.ti.com/video</a>

### TI E2E Community

[e2e.ti.com](http://e2e.ti.com)