

UMC



UM91531

Parallel Input Tone/Pulse Dialer

Features

- 4-bit parallel data input from microcomputer.
- TTL compatible inputs and outputs.
- Uses TV crystal standard (3.58 MHz) to derive all frequencies, providing high accuracy and stability.
- Operating voltage: 2.5 to 5.5 Volts.
- Selectable M/B ratio.

- 10 PPS dial rate.
- DTMF signaling of digits 0 - 9, *, #, A, B, C, and D.
- Pulse signaling of 0-9, *, #, and A.
- High group tone pre-emphasis: 2 dB.
- Low total harmonic distortion in DTMF signaling.
- RS-470 and CEPT compatible.

General Description

The UM91531 provides a 4-bit data input and a handshaking signal to serve as microcomputer interfaces. Under microcomputer control the UM91531 generates both a DTMF signal and a pulse output for telephone dialing. All necessary dual-tone frequencies and dial pulse outputs are derived from the widely

used TV crystal standard, providing high accuracy and stability. The required sinusoidal waveform for individual tones is digitally synthesized on the chip, resulting in a waveform with very low total harmonic distortion.

Pin Configuration

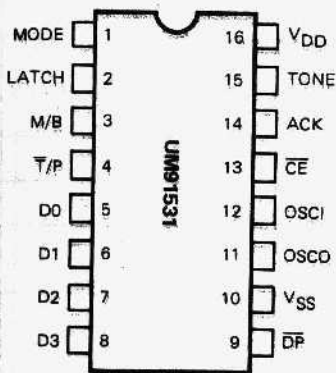

Block Diagram

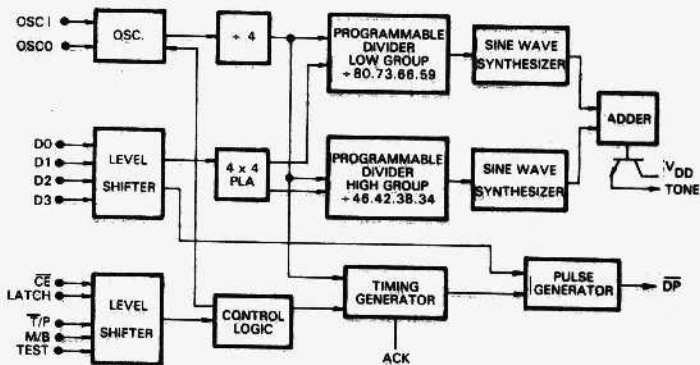

Absolute Maximum Ratings *

Power supply voltage ($V_{DD}-V_{SS}$).....	-0.3V to +5.5V
Input voltage (V_{IN}).....	-0.3V to $V_{DD}+0.3V$
Maximum power dissipation (at 25°C).....	600 mW
Operating temperature (T_{OP}).....	-20°C to +60°C
Storage temperature (T_{STG}).....	-55°C to +125°C

***Comments**

Stresses above those listed under "Absolute Maximum Ratings" may cause permanent damage to the device. These are stress ratings only. Functional operation of this device at these or any other conditions above those indicated in the operational sections of this specification is not implied and exposure to absolute maximum rating conditions for extended periods may affect device reliability.

DC Characteristics

($V_{DD} = 3.5V$, $V_{SS} = 0V$, $F_{OSC} = 3.579545$ MHz, and $T_{OP} = 25^\circ C$ unless otherwise specified.)

Parameter	Symbol	Min.	Typ.	Max.	Unit	Conditions	Test Ckt.
Operating Voltage	V_{DD}	2.5		5.5	V		B
Supply Operating Current	I_{DDP}		0.42	1	mA	$\overline{CE} = V_{SS}$ All outputs unloaded	B
	I_{DDT}		0.42	1			
Stand-by Current	I_{SD}		5	8	μA	$\overline{CE} = V_{DD}$ All outputs unloaded	A
\overline{DP} Output Sink Current	I_{OL1}	1			mA	$V_{DD} = 2.5V, V_{OL} = 0.4V$ $V_{DD} = 5.0V, V_{OL} = 0.4V$	C
	I_{OL2}	3					
Input Voltage Range	V_{IH}	0.8		1	V_{DD}		—
	V_{IL}	0		0.2			
Input Current Range	I_{IH}		0.05		μA		—
	I_{IL}		-0.05		μA		
Mode Pull-up Resistance	R_M	40			Kohm	$V_{DD} = 2.5V$	—
		20			Kohm	$V_{DD} = 5V$	C
ACK Source Current	I_{OHACK}	1.6			mA	$V_{DD} = 5V, V_{OH} = 2.4V$	C
ACK Sink Current	I_{OLACK}	4.0			mA	$V_{DD} = 5V, V_{OL} = 0.4V$	
D0,D1,D2,D3, T/P, M/B, LATCH, \overline{CE}	These pins TTL compatible I/O						—
Single Row Tone Output Amplitude	V_{OR}	770	840	910	mVp-p	$V_{DD} = 2.5V, R_L = 2.2Kohm$	B
		980	1070	1160		$V_{DD} = 5.5V, R_L = 2.2Kohm$	
Single Column Tone Output Amplitude	V_{OC}	980	1060	1160	mVp-p	$V_{DD} = 2.5V, R_L = 2.2Kohm$	B
		1250	1350	1450		$V_{DD} = 5.5V, R_L = 2.2Kohm$	
Pre-emphasis	Twist	1	2	3	dB		B
Valley of Single Tone	V_V		0.35		V_{DD}	$V_{DD} = 3.5V$	B
Distortion	DIS		1	5	%	See note	B

$$\text{Note: DIS.(\%)} = \frac{100(V_1^2 + V_2^2 + \dots + V_n^2)^{1/2}}{(V_L^2 + V_H^2)^{1/2}}$$

- 1) $V_1 \dots V_n$ are the intermodulations or harmonic frequencies in the 500 Hz to 3400 Hz band,
- 2) V_H, V_L are the individual frequency components of the DTMF signal.

AC Characteristics
 $(V_{DD} = 3.5V, V_{SS} = 0.V, F_{OSC} = 3.579545 \text{ MHz}, T_{OP} = 25^{\circ}C \text{ unless otherwise specified.})$

Parameter	Symbol	Min.	Typ.	Max.	Unit	Conditions
PULSE						
Make/Break Ratio	M/B		1/2			M/B = V_{DD}
			2/3			M/B = V_{SS}
Make Time	T_M		33.3		ms	M/B = 1/2
			40			M/B = 2/3
Break Time	T_B		66.6		ms	M/B = 1/2
			60			M/B = 2/3
Inter-digit Pause Time	T_{IDP}		790		ms	M/B = 1/2
			783			M/B = 2/3
Predigit Pause	T_{PDP}		15		ms	M/B = 1/2
			15			M/B = 2/3
TONE						
Minimum Tone Duration	T_{MFD}		70		ms	
Minimum Tone Inter-digit Pause	T_{TIDP}		70		ms	
Tone Output Pre-digit Pause	T_{TPDP}		0		ms	
Oscillator Set-up Time	T_{START}		5		ms	

Row/Column	Conditions	Spec.	Actual	Error (%)	Unit
R1	$F_{OSC} = 3.579 \text{ MHz}$	697	699.1	+0.31	Hz
R2		770	766.2	-0.49	Hz
R3		852	847.4	-0.54	Hz
R4		941	948.0	+0.74	Hz
C1		1209	1215.9	+0.57	Hz
C2		1336	1331.7	-0.32	Hz
C3		1477	1471.9	-0.35	Hz
C4		1633	1645.0	+0.73	Hz

Note: % Error does not include oscillator drift.

Pin Description

Pin	Designation	Description
1	MODE	Tone mode select input. When this input is high, the tone output and ACK output are normal. When this input is low, a DTMF signal will be generated continuously and any new input data will be ignored. This input affects the tone output mode only.
2	LATCH	Latch input. When input on this pin changes from low to high (at the rising edge), the UM91531 latches the 4-bit input data and T/P input. The latch input should not be changed back from low to high again until the ACK output falls low, and new data must not be latched while the ACK output is still low.
3	M/B	Make/Break ratio select input. This pin is used to select one of two available make/break ratios. A high input selects the 2/3 make/break ratio; a low input selects the 1/2 ratio. This input should be connected to V_{DD} or V_{SS} only. Changing the state of this pin when \overline{CE} is active (low) enables the test mode.
4	$\overline{T/P}$	Tone/pulse mode select input. This input determines whether tone or pulse mode will be activated. It is latched together with the 4-bit data input.
5-8	D0-D3	4-bit data input pins. This 4-bit parallel input is used to receive data generated by the microcomputer. (Input data vs. output signal is shown in table 1.) Valid input data should be presented at these inputs before and during the rising edge of the latch signal.
9	\overline{DP}	Dial pulse output. The dial pulse output consists of an N-channel open drain device. During dial pulse break periods this output is switched on (sinking current to V_{SS}); it is switched off during all other states. Dialing rate is 9.71 PPS and post-digit pause is 823 ms. (The output of this pin during test mode is discussed below.)
10 16	V_{SS} V_{DD}	Negative power supply input. Positive power supply input (operating range 2.5 to 5.5 volts).
11 12	OSCO OSCI	Oscillator output. Oscillator input. The UM91531 contains an oscillator circuit with the necessary parasitic capacitance and feedback resistor on chip, making it necessary to connect only a standard 3.58 MHz TV crystal across the OSCL and OSCO terminals to implement the oscillator function. An external clock input can be applied to the OSCL pin directly. The oscillator is enabled when the \overline{CE} input is low.
13	\overline{CE}	Chip enable input. This input controls the onset of oscillation and serves as the master reset for this device.
14	ACK	Acknowledge output. This pin provides an acknowledge signal to the microcomputer. This output is high when the device is ready to dial out the next digit; it falls low immediately after the rising edge of the latch signal.
15	TONE	DTMF signal output. This pin consists of an NPN transistor output, with the collector connected to V_{DD} . This pin is also connected to the emitter output. The internally generated DTMF signal is delivered to the base of the NPN transistor and is amplified as the transistor connected in common collector or darlington output forms. DTMF signaling output time is 70 ms and the interdigit interval is 70 ms. Typical output impedance of the DTMF signal is 1.25 Kohm, and the h_{FE} of the NPN transistor is at least 30 at $I_C = 3$ mA.

Functional Description
Input Data vs. Output Signal

Parallel binary signals on Do — D3 pins are input from microcomputer. Output signal vs. input data is shown in table 1:

D3	D2	D1	D0	DTMF Signaling	PULSE Signal (O/P Pulse No.)
0	0	0	0	0	10
0	0	0	1	1	1
0	0	1	0	2	2
0	0	1	1	3	3
0	1	0	0	4	4
0	1	0	1	5	5
0	1	1	0	6	6
0	1	1	1	7	7
1	0	0	0	8	8
1	0	0	1	9	9
1	0	1	0	*	10
1	0	1	1	#	11
1	1	0	0	A	12
1	1	0	1	B	13
1	1	1	0	C	14
1	1	1	1	D	Forbidden input

Table 1.
Input Data vs. Output Signal in Test Mode

The UM91531 provides a high speed pulse/tone output for testing consideration. If the M/B input changes state after the UM91531 is enabled, the test mode is initiated and the device will remain in test mode unless disabled. Table 2 shows input data vs. output signal in pulse/tone test mode.

D3, D2, D1, D0 Input In Hex Code	Tone O/P Frequencies and Test Mode		Pulse O/P Frequencies and Test Mode
	Tone Pin O/P	\overline{DP} Pin O/P	\overline{DP} Pin O/P
0	948.0	1,331.7 x 8	10 x 48
1	699.1	1,215.9 x 8	1 x 48
2	1,331.7	699.1 x 8	2 x 48
3	1,417.9	699.1 x 8	3 x 48
4	1,215.9	766.2 x 8	4 x 48
5	1,331.7	766.2 x 8	5 x 48
6	766.2	1,471.9 x 8	6 x 48

Table 2

Pin Description

Pin	Designation	Description
1	MODE	Tone mode select input. When this input is high, the tone output and ACK output are normal. When this input is low, a DTMF signal will be generated continuously and any new input data will be ignored. This input affects the tone output mode only.
2	LATCH	Latch input. When input on this pin changes from low to high (at the rising edge), the UM91531 latches the 4-bit input data and T/P input. The latch input should not be changed back from low to high again until the ACK output falls low, and new data must not be latched while the ACK output is still low.
3	M/B	Make/Break ratio select input. This pin is used to select one of two available make/break ratios. A high input selects the 2/3 make/break ratio; a low input selects the 1/2 ratio. This input should be connected to V_{DD} or V_{SS} only. Changing the state of this pin when \overline{CE} is active (low) enables the test mode.
4	$\overline{T/P}$	Tone/pulse mode select input. This input determines whether tone or pulse mode will be activated. It is latched together with the 4-bit data input.
5-8	D0-D3	4-bit data input pins. This 4-bit parallel input is used to receive data generated by the microcomputer. (Input data vs. output signal is shown in table 1.) Valid input data should be presented at these inputs before and during the rising edge of the latch signal.
9	\overline{DP}	Dial pulse output. The dial pulse output consists of an N-channel open drain device. During dial pulse break periods this output is switched on (sinking current to V_{SS}); it is switched off during all other states. Dialing rate is 9.71 PPS and post-digit pause is 823 ms. (The output of this pin during test mode is discussed below.)
10 16	V_{SS} V_{DD}	Negative power supply input. Positive power supply input (operating range 2.5 to 5.5 volts).
11 12	OSCO OSCI	Oscillator output. Oscillator input. The UM91531 contains an oscillator circuit with the necessary parasitic capacitance and feedback resistor on chip, making it necessary to connect only a standard 3.58 MHz TV crystal across the OSCI and OSCO terminals to implement the oscillator function. An external clock input can be applied to the OSCI pin directly. The oscillator is enabled when the \overline{CE} input is low.
13	\overline{CE}	Chip enable input. This input controls the onset of oscillation and serves as the master reset for this device.
14	ACK	Acknowledge output. This pin provides an acknowledge signal to the microcomputer. This output is high when the device is ready to dial out the next digit; it falls low immediately after the rising edge of the latch signal.
15	TONE	DTMF signal output. This pin consists of an NPN transistor output, with the collector connected to V_{DD} . This pin is also connected to the emitter output. The internally generated DTMF signal is delivered to the base of the NPN transistor and is amplified as the transistor connected in common collector or darlington output forms. DTMF signaling output time is 70 ms and the interdigit interval is 70 ms. Typical output impedance of the DTMF signal is 1.25 Kohm, and the f_{HE} of the NPN transistor is at least 30 at $I_C = 3$ mA.

Functional Description
Input Data vs. Output Signal

Parallel binary signals on Do – D3 pins are input from microcomputer. Output signal vs. input data is shown in table 1:

D3	D2	D1	D0	DTMF Signaling	PULSE Signal (O/P Pulse No.)
0	0	0	0	0	10
0	0	0	1	1	1
0	0	1	0	2	2
0	0	1	1	3	3
0	1	0	0	4	4
0	1	0	1	5	5
0	1	1	0	6	6
0	1	1	1	7	7
1	0	0	0	8	8
1	0	0	1	9	9
1	0	1	0	*	10
1	0	1	1	#	11
1	1	0	0	A	12
1	1	0	1	B	13
1	1	1	0	C	14
1	1	1	1	D	Forbidden input

Table 1.
Input Data vs. Output Signal in Test Mode

The UM91531 provides a high speed pulse/tone output for testing consideration. If the M/B input changes state after the UM91531 is enabled, the test mode is initiated and the device will remain in test mode unless disabled. Table 2 shows input data vs. output signal in pulse/tone test mode.

D3, D2, D1, D0 Input In Hex Code	Tone O/P Frequencies and Test Mode		Pulse O/P Frequencies and Test Mode
	Tone Pin O/P	DP Pin O/P	DP Pin O/P
0	948.0	1,331.7 x 8	10 x 48
1	699.1	1,215.9 x 8	1 x 48
2	1,331.7	699.1 x 8	2 x 48
3	1,417.9	699.1 x 8	3 x 48
4	1,215.9	766.2 x 8	4 x 48
5	1,331.7	766.2 x 8	5 x 48
6	766.2	1,471.9 x 8	6 x 48

Table 2.

D3, D2, D1, D0 Input In Hex Code	Tone O/P Frequencies and Test Mode		Pulse O/P Frequencies and Test Mode
	Tone Pin O/P	\overline{DP} Pin O/P	\overline{DP} Pin O/P
7	847.4	$1,215.9 \times 8$	7×48
8	1,331.7	847.4×8	8×48
9	1,471.9	847.4×8	9×48
A	1,215.9	948.0×8	10×48
B	1,471.9	948.0×8	11×48
C	1,645.0	699.1×8	12×48
D	1,645.0	766.2×8	13×48
E	1,645.0	847.4×8	14×48
F	1,645.0	948.0×8	0

Note: Tone Pin O/P in sine wave, \overline{DP} Pin O/P in square wave. The normal timing is reduced to 1/8 at tone test mode and 1/48 at pulse test mode.

Table 2. (continued)

N-Channel Open Drain Output

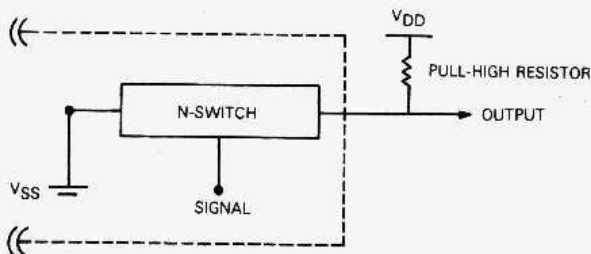

DTMF Generator

The DTMF signal is produced from the tone frequency generator circuit with an NPN transistor-emitter-follower output buffer (Figure 1). The digitally synthesized sinewave has a 7-level, 16 segment (1.1V + 1.3V) reference voltage (Figure 2). The DTMF's total harmonic distortion is 5% maximum. Total harmonic distortion (THD) vs. operating voltage and DTMF output vs. operating voltage is shown in Figures 3 and 4.

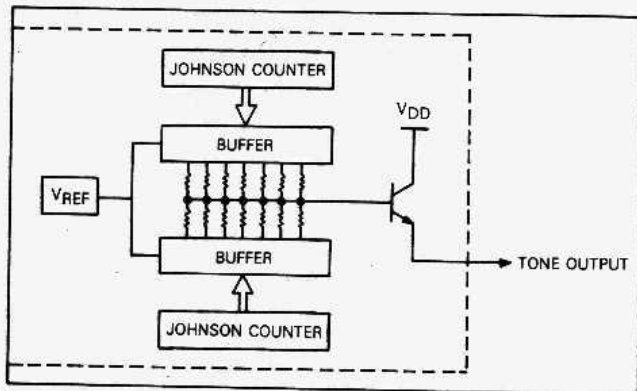
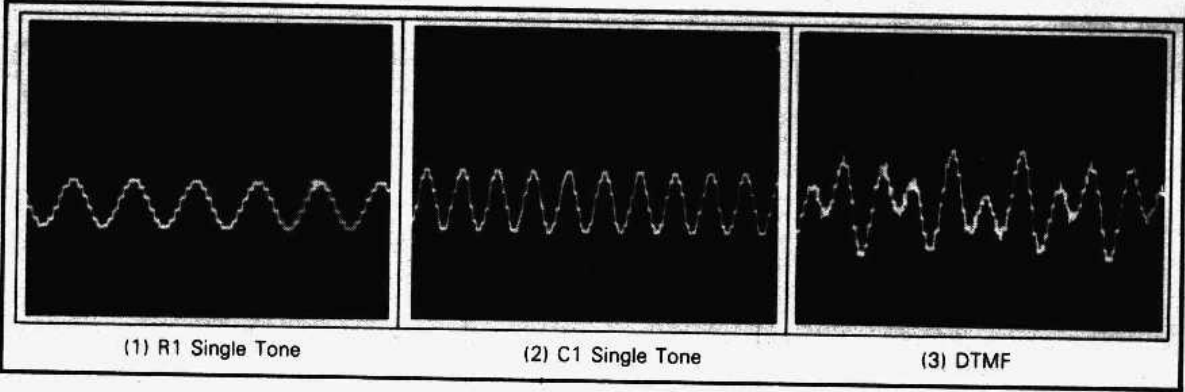
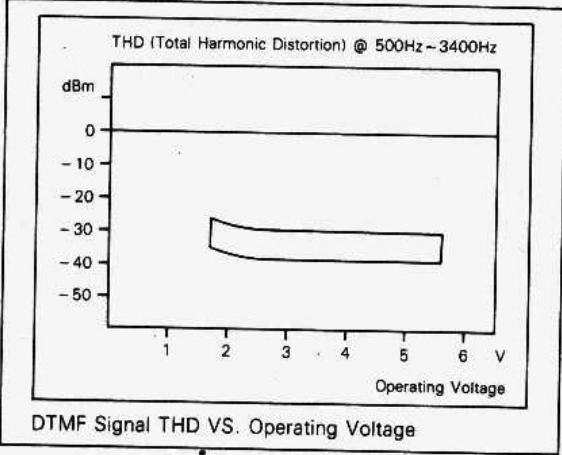
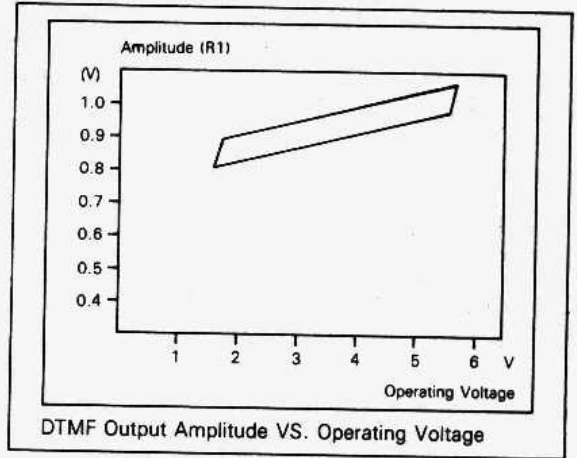

Figure 1

Figure 2: DTMF Waveforms

Figure 3.

Figure 4.
Timing Diagram
