



3-Terminal 1.5A Positive Adjustable Voltage Regulator

Description

The LM317 is an adjustable 3-terminal positive voltage regulator, designed to supply more than 1.5A of output current with voltage adjustable from 1.3 to 37V.

Features

- Output current up to 1.5A.
- Output voltage adjustable from 1.3V to 37V.
- Internal short circuit protection.
- Internal over temperature protection.
- Safe-Area compensation for output transistor.

Package Dimensions

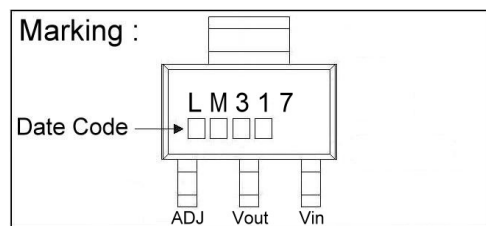
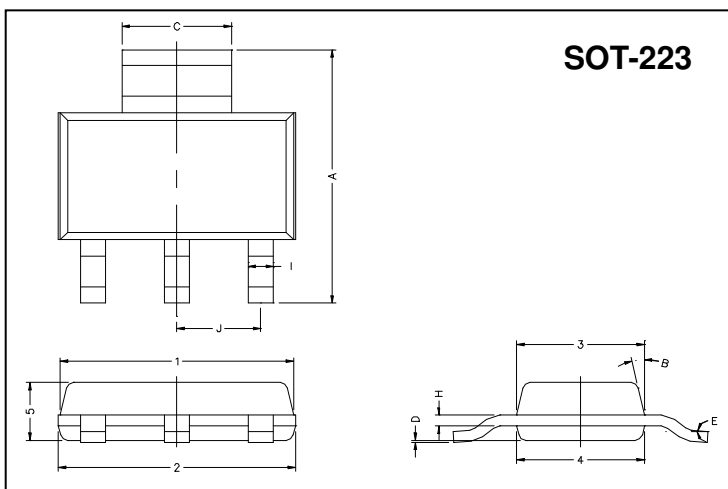

REF.	Millimeter		REF.	Millimeter	
	Min.	Max.		Min.	Max.
A	6.70	7.30	B	13° TYP.	
C	2.90	3.10	J	2.30 REF.	
D	0.02	0.10	1	6.30	6.70
E	0°	10°	2	6.30	6.70
I	0.60	0.80	3	3.30	3.70
H	0.25	0.35	4	3.30	3.70
			5	1.40	1.80

Block Diagram

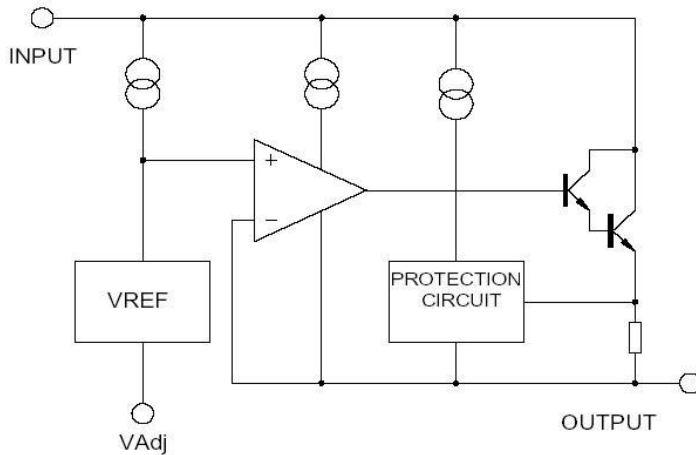

Absolute Maximum Ratings at Ta = 25°C

Parameter	Symbol	Ratings	Unit
Input-Output Voltage Difference	Vi-Vo	40	V
Load Temperature	Tlead	230	°C
Power Dissipation	PD	2	W
Operating Temperature Range	Topr	0~+125	°C
Storage Temperature Range	Tstg	-65~+150	°C



3-Terminal 1.5A Positive Adjustable Voltage Regulator

Electrical Characteristics

($V_i - V_o = 5V$, $0^\circ C < T_j < 125^\circ C$, $I_o = 500mA$, $I_{Max} = 1.5A$, $P_{Max} = 8W$, unless otherwise specified)

Parameter	Symbol	Test Conditions	Min	TYP	Max	Unit	
Line Regulation	ΔV_o	$T_a = 25^\circ C$, $3V \leq V_i - V_o \leq 40V$	-	0.01	0.04	%/V	
		$T_a = 0 \sim 125^\circ C$, $3V \leq V_i - V_o \leq 40V$	-	0.02	0.07	%/V	
Load Regulation	ΔV_o	$T_a = 25^\circ C$	-	18	25	mV	
		$10mA \leq I_o \leq I_{Max}$	-	0.4	0.5	%/V _o	
		$10mA \leq I_o \leq I_{Max}$	$V_o \leq 5V$	-	40	70	mV
			$V_o \geq 6V$	-	0.8	1.5	%/V _o
Adjustable Pin Current	IADJ		-	46	100	μA	
Adjustable Pin Current Change	$\Delta IADJ$	$2.5V \leq V_i - V_o \leq 40V$, $10mA \leq I_o \leq I_{Max}$, $PD \leq P_{Max}$	-	2.0	5	μA	
Reference Voltage	VREF	$3V \leq V_i - V_o \leq 40V$, $10mA \leq I_o \leq I_{Max}$, $PD \leq P_{Max}$	1.225	1.25	1.275	V	
Temperature Stability	STT		-	0.7	-	%/V _o	
Minimum Load Current for Regulation	$I_L(\text{Min})$	$V_i - V_o = 40V$	-	3.5	10	mA	
Maximum Output Current	$I_o(\text{Max})$	$V_i - V_o \leq 15V$, $PD < P_{Max}$	1.5	2.2	-	A	
		$V_i - V_o = 40V$, $PD < P_{Max}$, $T_j = 25^\circ C$	0.15	0.4	-		
RMS Noise vs. % of V _{out}	eN	$T_a = 25^\circ C$, $10Hz \leq f \leq 10KHz$	-	0.003	0.01	%/V _o	
Ripple Rejection	RR	$V_o = 10V$, $f = 120Hz$	-	60	-	dB	
		$V_o = 10V$, $f = 120Hz$, $C_{adj} = 10\mu F$	66	75	-		
Long-term Stability, $T_j = \text{Thigh}$	ST	$T_a = 25^\circ C$, 1000hr	-	0.3	1	%	
Junction to Case Thermal Resistance	$R\theta_{jc}$	-	-	15	-	$^\circ C/W$	

*Note: Testing with low duty pulse should be used to avoid heating effect.

Characteristics Curve

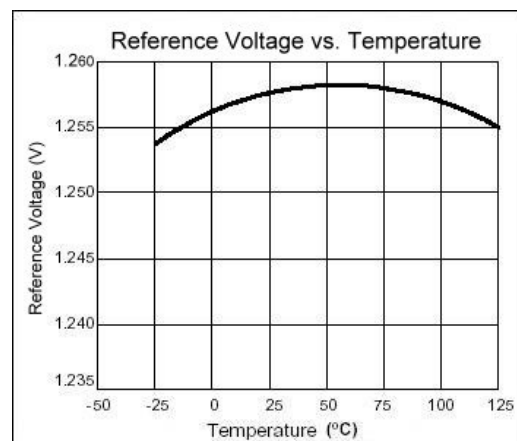
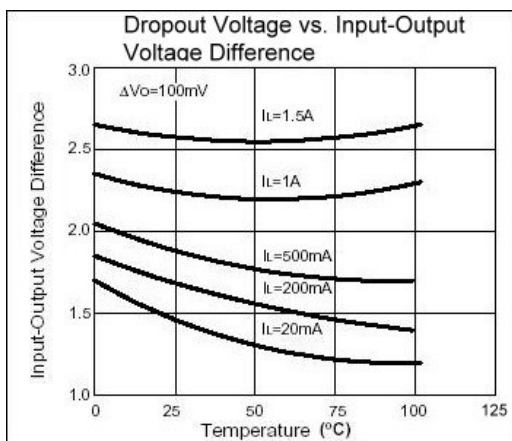
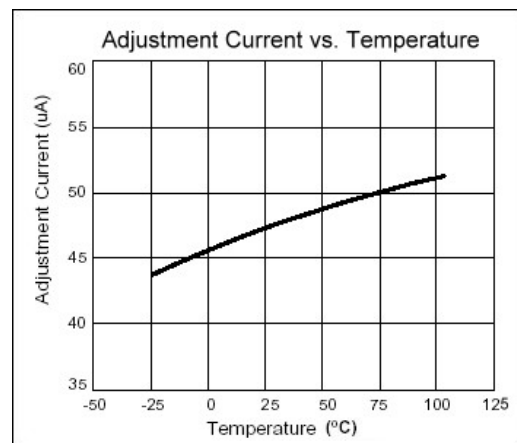
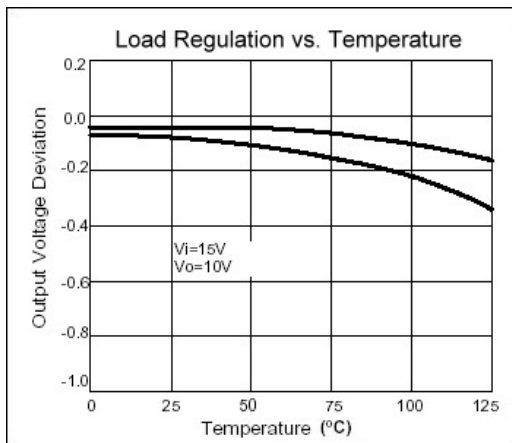



3-Terminal 1.5A Positive Adjustable Voltage Regulator

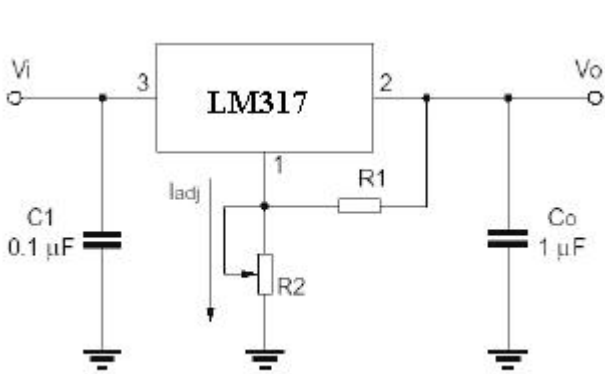

Fig.1 Programmable voltage regulator
 $V_o = 1.25V * (1 + R_2/R_1) + I_{adj} * R_2$
 C1 is required when regulator is located an appreciated distance from power supply. Co is needed to improve transient response.

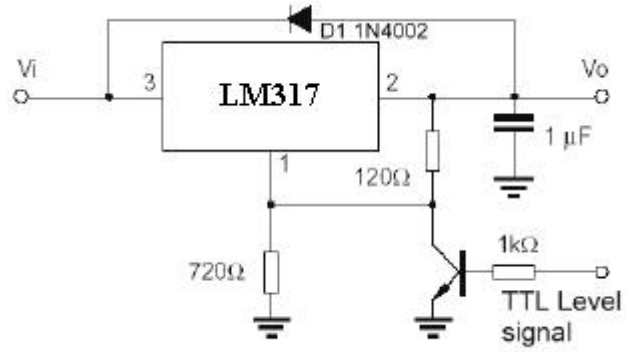

Fig.2 Regulator with On-off control

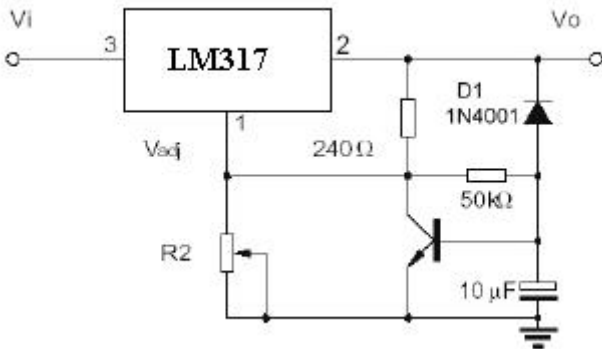

Fig.3 Soft start application

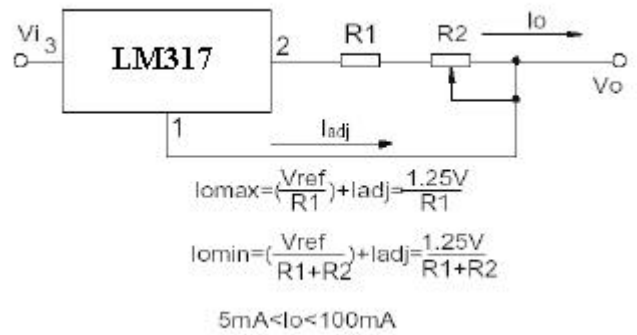

Fig.4 Constant current application