

SPS-4102WG / SPS-4102BWG / SPS-4102AWG

(RoHS Compliant)

3.3V / 1310 nm / 8.5 Gbps Digital Diagnostic SFP+ LC SINGLE-MODE TRANSCEIVER

FEATURES

- | Up to 8.5 Gb/s Bi-directional Data Link
- | Compliant to SFP+ MSA
- | Compliance with Fibre Channel FC-PI-4 800-SM-LC-I
- | Compliant with 4x /2x Fibre Channel
- | **SFF-8472 Digital Diagnostic Function**
- | 1310 nm FP LD Transmitter
- | Link Distance
 - 0 to 1400 m at 8.5 Gb/s
 - 0 to 5000 m at 4.25 Gb/s
 - 0 to 10,000 m at 2.125Gb/s
- | AC/AC Coupling according to MSA
- | Single +3.3 V Power Supply
- | RoHS 6/6 Compliant
- | 0 to 70°C Operating: SPS-4102WG
- | -10 to 85°C Operating: SPS-4102BWG
- | -40 to 85°C Operating: SPS-4102AWG
- | Class 1 Laser International Safety Standard IEC-60825 Compliant

DESCRIPTION

The SPS-4102WG series single mode transceiver is small form factor pluggable module for bi-directional serial optical data communications such as 8x/4x/2x/1x Fibre Channel. It is with the SFP+ 20-pin connector to allow hot plug capability. Digital diagnostic functions are available via an I²C. This module is designed for single mode fiber and operates at a nominal wavelength of 1310 nm. The transmitter section uses a 1310 nm multiple quantum well laser and is a class 1 laser compliant according to International Safety Standard IEC-60825. The receiver section uses an integrated InGaAs detector preamplifier (IDP) mounted in an optical header and a limiting post-amplifier IC.

LASER SAFETY

This single mode transceiver is a Class 1 laser product. It complies with IEC-60825 and FDA 21 CFR 1040.10 and 1040.11. The transceiver must be operated within the specified temperature and voltage limits. The optical ports of the module shall be terminated with an optical connector or with a dust plug.

APPLICATIONS

- | Multi-rate 8x / 4x / 2x Fibre Channel

ORDER INFORMATION

P/No.	Bit Rate (Gb/s)	FC-PI	Distance (m)	Wavelength (nm)	Package	Temp. (°C)	RoHS Compliant
SPS-4102WG	8 / 4 / 2	FC-PI-4	1400*	1310	SFP+ with DMI	0 to 70	Yes
SPS-4102BWG	8 / 4 / 2	FC-PI-4	1400*	1310	SFP+ with DMI	-10 to 85	Yes
SPS-4102AWG	8 / 4 / 2	FC-PI-4	1400*	1310	SFP+ with DMI	-40 to 85	Yes

*: 0 to 1400 m at 8.5 Gb/s, 0 to 5000 m at 4.25 Gb/s, and 10 km at FC 1x/2x.

Absolute Maximum Ratings					
Parameter	Symbol	Min	Max	Units	Notes
Storage Temperature	Tstg	-40	85	°C	
Operating Case Temperature	Topr	0	70	°C	SPS-4102WG
		-10	85		SPS-4102BWG
		-40	85		SPS-4102AWG
Power Supply Voltage	Vcc	-0.5	3.6	V	

Recommended Operating Conditions					
Parameter	Symbol	Min	Typ	Max	Units / Notes
Power Supply Voltage	Vcc	3.13	3.3	3.47	V
Operating Case Temperature	Topr	0		70	°C / SPS-4102WG
		-10		85	°C / SPS-4102BWG
		-40		85	°C / SPS-4102AWG
Power Supply Current	I _{CC(TX+RX)}		250	300	mA
Data Rate		1	8.5		Gb/s

Transmitter Optical Specifications (0°C < Topr < 70°C, 3.13V < Vcc < 3.47V)						
Parameter	Symbol	Min	Typ	Max	Units	Notes
Average Launch Power	P _{O, Avg}	-8		0	dBm	1
Optical Modulation Amplitude	P _{O, OMA}	0.29			mW	
Output Center Wavelength	λ _c	1270	1310	1350	nm	
Output Spectrum Width	σ _λ		2		nm	RMS (σ)
Optical Rise / Fall Time (8.5Gb/s)	t _r / t _f			50	ps	20 % to 80% ,unfiltered
Relative Intensity Noise	RIN			-128	dB/Hz	
Average Launch Power of OFF Transmitter				-30	dBm	

1. Output power is power coupled into a 9/125 μm single-mode fiber.

Receiver Optical Specifications (0°C < Topr < 70°C, 3.13V < Vcc < 3.47V)						
Parameter	Symbol	Min	Typ	Max	Units	Notes
Unstressed Sensitivity at 8.5 Gb/s	Sens			0.042	mWp-p	2, OMA
				-15	dBm	3, Average Power
Stress Sensitivity at 8.5 Gb/s	Sens		---	0.066	mWp-p	2, OMA
Receiver Overload	P _{MAX}	0.5	---		dBm	
LOS -- Deasserted	LOS _D	---	---	-16	dBm	Transition: low to high
LOS -- Asserted	LOS _A	-28	---	---	dBm	Transition: high to low
Wavelength of Operation	λ _c	1260		1565	nm	
Optical Return Loss	ORL			-12	dB	

2. Measured with worst ER; BER < 10⁻¹² and PRBS 2⁷-1.

3. Represents sensitivity based on OMA spec, as corrected to incoming Extinction Ratio of 7 dB. For example, an OMA of 0.042 mW is approximately equal to an average power of -15 dBm, average with an Extinction ratio of 7 dB.

Electrical Characteristics						
Parameter	Symbol	Min	Typ	Max	Units	Notes
High-Speed Signal (CML) Interface Specification						
Input Data Rate		1	8.5		Gb/s	
Differential Input Impedance	R _{in}		100		Ω	
Differential Data Input Amplitude		150		1200	mVpp	Internally AC coupled
Output Data Rate		1	8.5		Gb/s	
Differential Output Impedance	R _{out}		100		Ω	
Differential Data Output Amplitude		350	600	700	mVpp	Internally AC coupled
Low-Speed Signal (LVTTTL) Interface Specification						
Input High Voltage		2.0		Vcc+0.3	V	
Input Low Voltage		GND		0.8	V	
Output High Voltage		2.4		Vcc	V	
Output Low Voltage		GND		0.5	V	

CONNECTION DIAGRAM

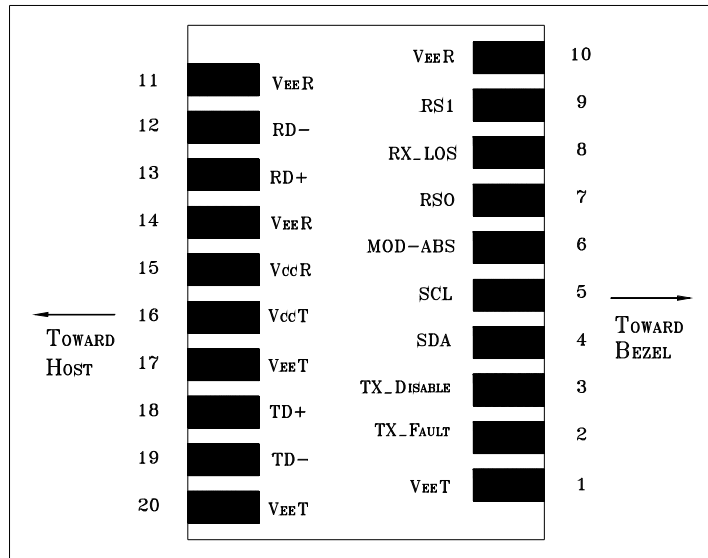

PIN	Signal Name	Description	PIN	Signal Name	Description
1	V _{EE} T	Transmitter Signal Ground	11	V _{EE} R	Receiver Signal Ground
2	TX_Fault	Transmitter Fault Indication. Logic “1” Output = Laser Fault. Logic “0” Output = Normal Operation	12	RD-	Inverse Receiver Data Out
3	TX_Disable	Logic “1” Input (or no connection) = Laser off, Logic “0” = Laser on.	13	RD+	Receiver Data Out
4	SDA	Modulation Definition 2 – Two wires serial ID Interface	14	V _{EE} R	Receiver Signal Ground
5	SDL	Modulation Definition 1 – Two wires serial ID Interface	15	V _{CC} R	Receiver Power – 3.3V±5%
6	MOD-ABS	Modulation Definition 0 – Ground in Module	16	V _{CC} T	Transmitter Power – 3.3V±5%
7	RS0	RX Rate Select (LVTTL). This pin has an internal 30k pulldown to ground. A signal on this pin will not affect module performance.	17	V _{EE} T	Transmitter Signal Ground
8	RX_LOS	Loss of Signal Out (OC).	18	TD+	Transmitter Data In
9	RS1	TX Rate Select (LVTTL). This pin has an internal 30k pulldown to ground. A signal on this pin will not affect module performance.	19	TD-	Inverse Transmitter Data In
10	V _{EE} R	Receiver Signal Ground	20	V _{EE} T	Transmitter Signal Ground

MODULE DEFINITION

Module Definition	PIN 4	PIN 5	PIN 6	Interpretation by Host
4	SDA	SCL	MOD-ABS	Serial module definition protocol

Module Definition 4 specifies a serial definition protocol. For this definition, upon power up, SDA and SDL appear as no connector (NC) and MOD-ABS is TTL LOW. When the host system detects this condition, it activates the serial protocol. The protocol uses the 2-wire serial CMOS E²PROM protocol of the ATMEL AT24C01A/02/04 family of components.

RECOMMENDED CIRCUIT SCHEMATIC

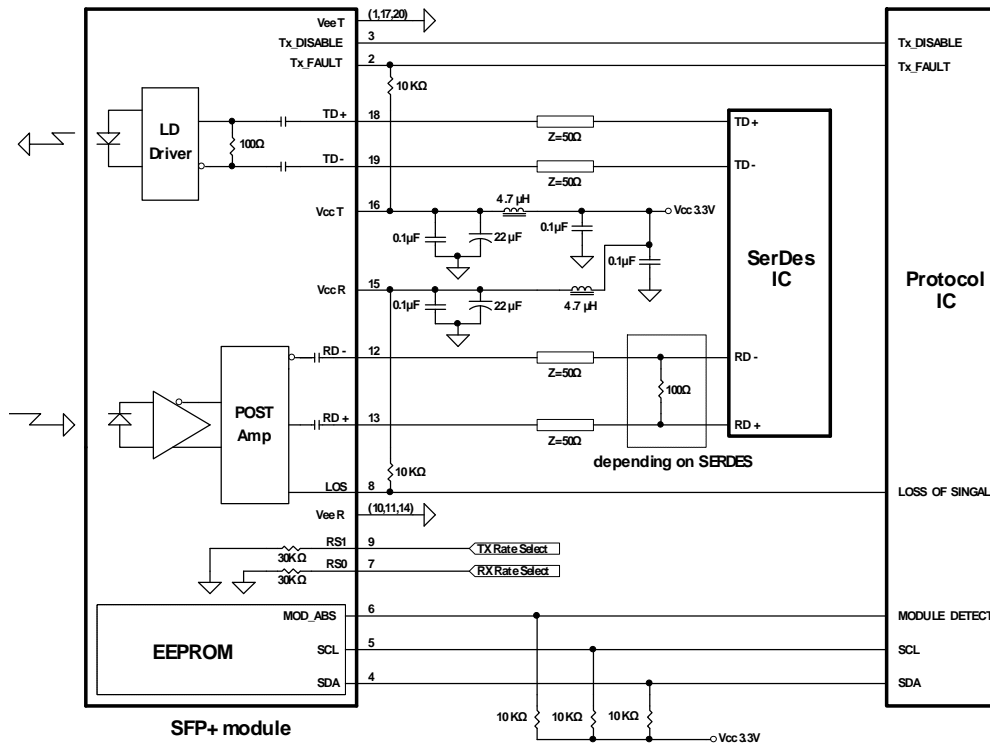

PACKAGE DIAGRAM

Units in mm

Top View

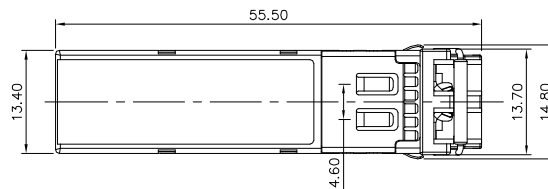

Front View

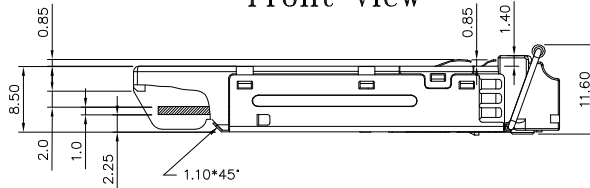

LATCH COLOR
BLUE : SM

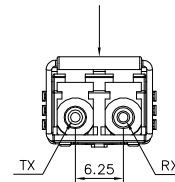

Side View

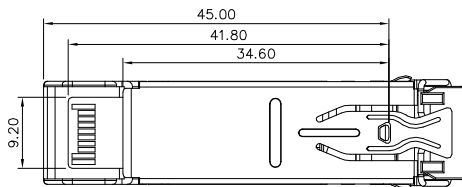

Bottom View

Note: Specifications subject to change without notice.

REVISION HISTORY

Version	Subject	Release Date
1.0	Initial datasheet	2007/7/1
2.0	Add SPS-4102AWG for -40 to 85°C	2007/12/1