

Standard Recovery Diodes, 90A (ADD-A-PAK Power Modules)



ADD-A-PAK

FEATURES

- High voltage
- 3000 V_{RMS} isolating voltage
- Industrial standard package
- UL approved file E320098
- Glass passivated chips
- Low thermal resistance
- Designed and qualified for industrial level
- Compliant to RoHs

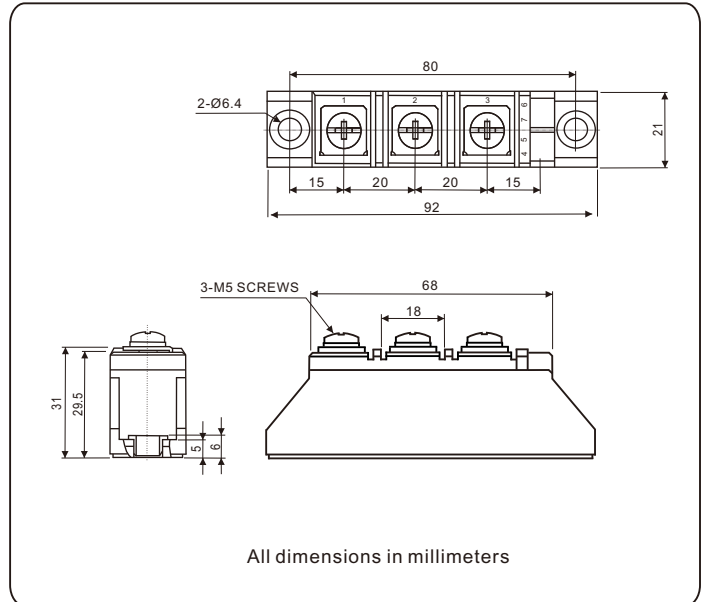

BENEFITS

- Excellent thermal performances obtained by the usage of exposed direct bonded copper substrate
- Up to 1600V
- High surge capability
- Easy mounting on heatsink

ELECTRICAL DESCRIPTION (APPLICATIONS)

These modules are intended for general purpose high voltage applications such as high voltage regulated power supplies, lighting circuits, temperature and motor speed control circuits, UPS and battery charger.

MECHANICAL DESCRIPTION

The new generation of ADD-A-PAK module, combines the excellent thermal performances obtained by the usage of exposed direct bonded copper substrate, with advanced compact simple package solution and simplified internal structure with minimized number of interfaces.

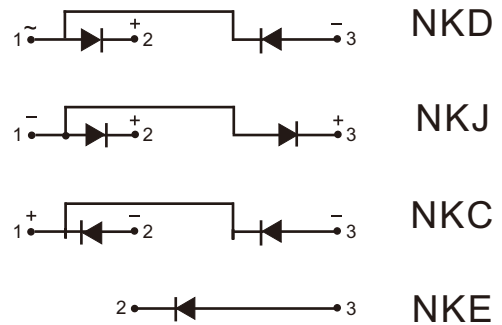

PRODUCT SUMMARY	
I _{F(AV)}	90A
Type	Modules-Diode, High Voltage

MAJOR RATINGS AND CHARACTERISTICS			
SYMBOL	CHARACTERISTICS	VALUES	UNIT
I _{F(AV)}	T _C = 100°C	90	A
I _{F(RMS)}		141	
I _{FSM}	50 HZ	2300	
	60 HZ	2408	
I ² t	50 HZ	26.45	kA ² s
	60 HZ	24.10	
I ² √t		264.5	kA ² √s
V _{RRM}	Range	400 to 1600	V
t _J		-40 to 150	°C
T _{stg}			

ELECTRICAL SPECIFICATIONS

VOLTAGE RATINGS				
TYPE NUMBER	VOLTAGE CODE	V_{RRM} , MAXIMUM REPETITIVE PEAK REVERSE VOLTAGE V	V_{RSM} , MAXIMUM NON-REPETITIVE PEAK REVERSE VOLTAGE V	I_{RRM} , MAXIMUM AT $T_J = 150^\circ\text{C}$ mA
NKD90..A NKJ90..A NKC90..A NKE90..A	04	400	500	8
	08	800	900	
	12	1200	1300	
	14	1400	1500	
	16	1600	1700	

FORWARD CONDUCTION						
PARAMETER	SYMBOL	TEST CONDITIONS			VALUES	UNIT
Maximum average forward current at case temperature	$I_{F(AV)}$	180° conduction, half sine wave			90	A
					100	°C
Maximum RMS forward current	$I_{F(RMS)}$	DC at 100°C case temperature			141	A
Maximum peak, one-cycle forward, non-repetitive surge current	I_{FSM}	t = 10ms	No voltage reapplied	Sinusoidal half wave, initial $T_J = T_J$ maximum	2300	A
		t = 8.3ms			2408	
		t = 10ms	100% V_{RRM} reapplied		1936	
		t = 8.3ms			2027	
Maximum I^2t for fusing	I^2t	t = 10ms	No voltage reapplied		26.45	kA ² s
		t = 8.3ms			24.10	
		t = 10ms	100% V_{RRM} reapplied		18.74	
		t = 8.3ms			17.05	
Maximum $I^2\sqrt{t}$ for fusing	$I^2\sqrt{t}$	t = 0.1 to 10 ms, no voltage reapplied			264.5	kA ² √s
Low level value of threshold voltage	$V_{F(TO)1}$	$(16.7\% \times \pi \times I_{F(AV)} < I < \pi \times I_{F(AV)})$, $T_J = T_J$ maximum			0.76	V
High level value of threshold voltage	$V_{F(TO)2}$	$(I > \pi \times I_{F(AV)})$, $T_J = T_J$ maximum			0.89	
Low level value of forward slope resistance	r_{f1}	$(16.7\% \times \pi \times I_{F(AV)} < I < \pi \times I_{F(AV)})$, $T_J = T_J$ maximum			2.4	mΩ
High level value of forward slope resistance	r_{f2}	$(I > \pi \times I_{F(AV)})$, $T_J = T_J$ maximum			2.05	
Maximum forward voltage drop	V_{FM}	$I_{FM} = 270\text{A}$, $T_J = 25^\circ\text{C}$, $t_p = 400 \mu\text{s}$ square wave			1.35	V

BLOCKING					
PARAMETER	SYMBOL	TEST CONDITIONS		VALUES	UNITS
Maximum peak reverse leakage current	I_{RRM}	$T_J = 150^\circ\text{C}$		8	mA
Maximum RMS insulation Voltage	V_{INS}	50 Hz		3000 (1 min) 3600 (1 s)	V

THERMAL AND MECHANICAL SPECIFICATIONS				
PARAMETER	SYMBOL	TEST CONDITIONS	VALUES	UNIT
Junction and storage temperature range	T_J, T_{stg}		-40 to 150	°C
Maximum internal thermal resistance, junction to case per leg	R_{thJC}	DC operation	0.22	°C/W
Typical thermal resistance, case to heatsink per module	R_{thCS}	Mounting surface flat, smooth and greased	0.1	
Mounting force, ±10%	to heatsink, M6	A mounting compound is recommended and the torque should be rechecked after a period of 3 hours to allow for the spread of the compound.	4	Nm
	busbar, M5		3	
Approximate weight			115	g
			4.06	oz.
Case style		JEDEC	ADD-A-PAK (TO-240AA)	

ΔR_{thJC} CONDUCTION											
DEVICES	SINE HALF WAVE CONDUCTION					RECTANGULAR WAVE CONDUCTION					UNITS
	180°	120°	90°	60°	30°	180°	120°	90°	60°	30°	
NKD90/NKJ90 NKC90/NKE90	0.057	0.068	0.087	0.12	0.177	0.045	0.073	0.093	0.123	0.178	°C/W

Note

- Table shows the increment of thermal resistance R_{thJC} when devices operate at different conduction angles than DC

Ordering Information Tabel

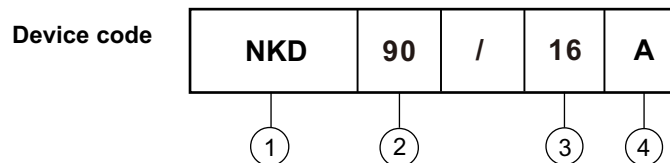

- ① - Module type, NKD/NKJ/NKC for (Diode + Diode) module
NKE for single diode
- ② - Current rating : $I_{F(AV)}$
- ③ - Voltage code x 100 = V_{RRM}
- ④ - Assembly type, "A" for soldering type

Nell High Power Products

Fig.1 Current ratings characteristics

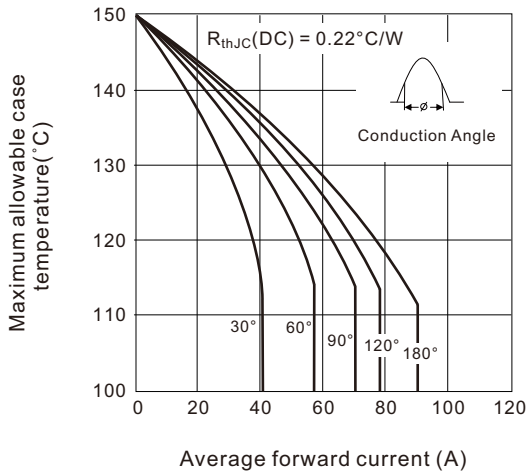

Fig.2 Current ratings characteristics

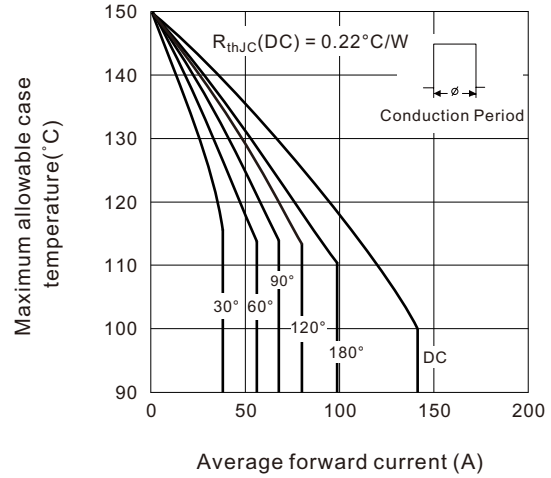

Fig.3 Forward Power Loss characteristics

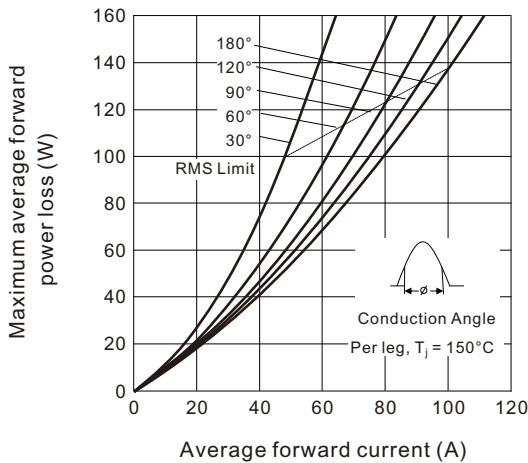

Fig.4 On-state power loss characteristics

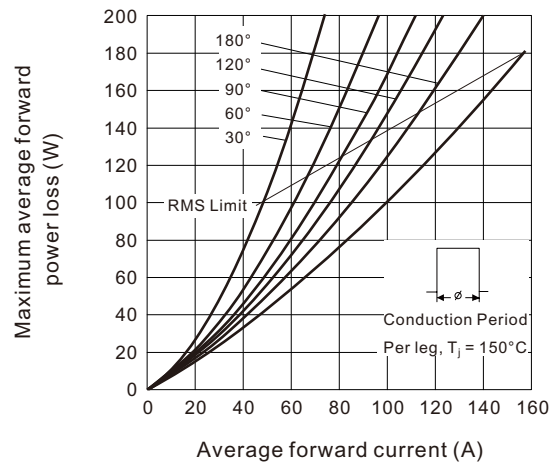

Fig.5 Maximum non-repetitive surge current

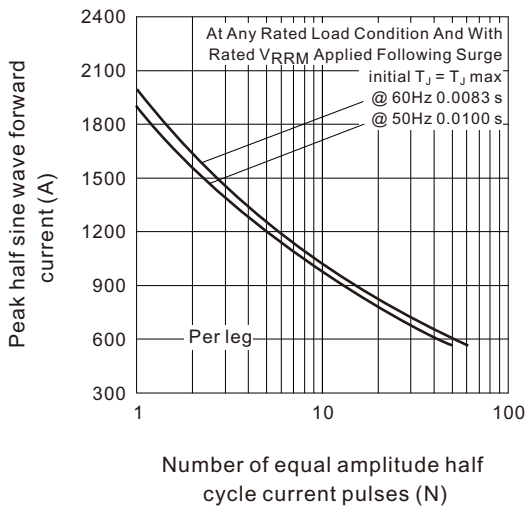

Fig.6 Maximum non-repetitive surge current

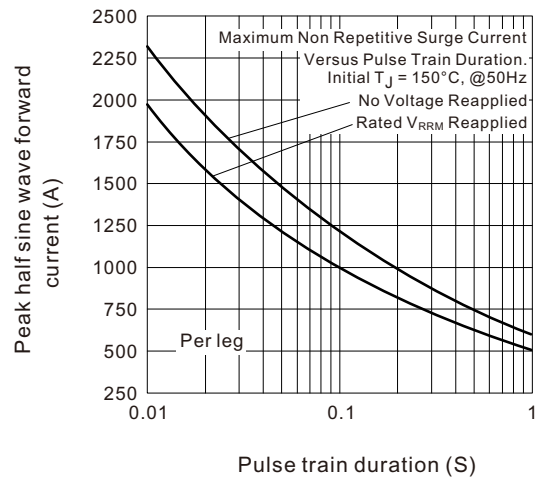

Fig.7 Forward power loss characteristics

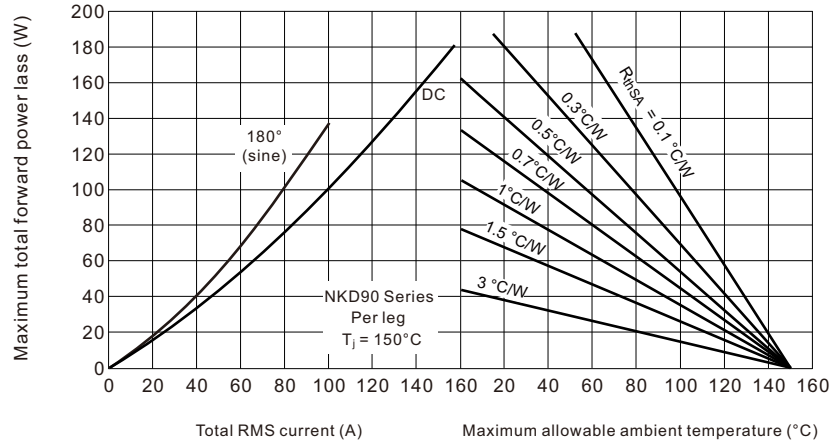

Fig.8 Forward power loss characteristics

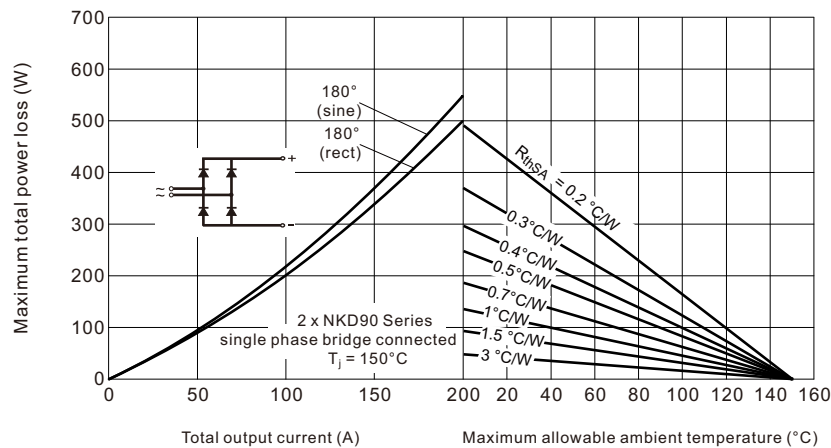

Fig.9 Forward power loss characteristics

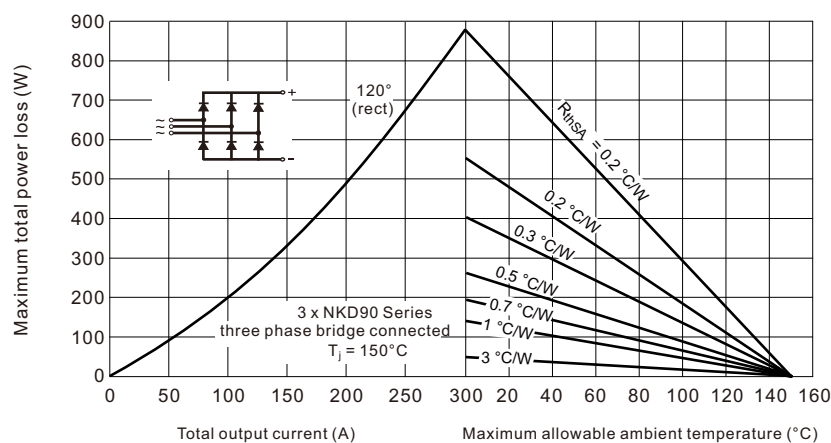

Fig.10 Forward voltage characteristics

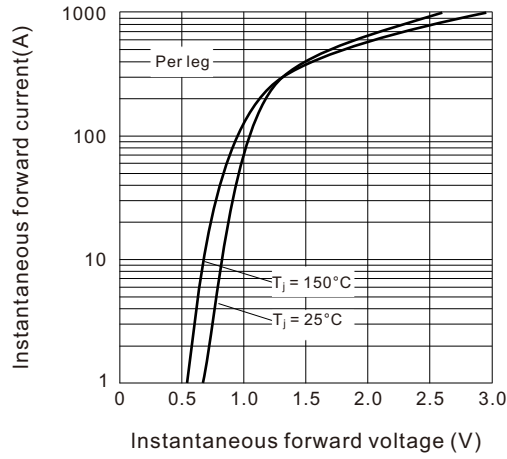

Fig.11 Thermal Impedance Z_{thJC} characteristics

