

DWG. NO. 220-510-0010G

REV	DESCRIPTION	BY DATE	APPD
B	ECN 2364	00/1/8 HMP	1/27

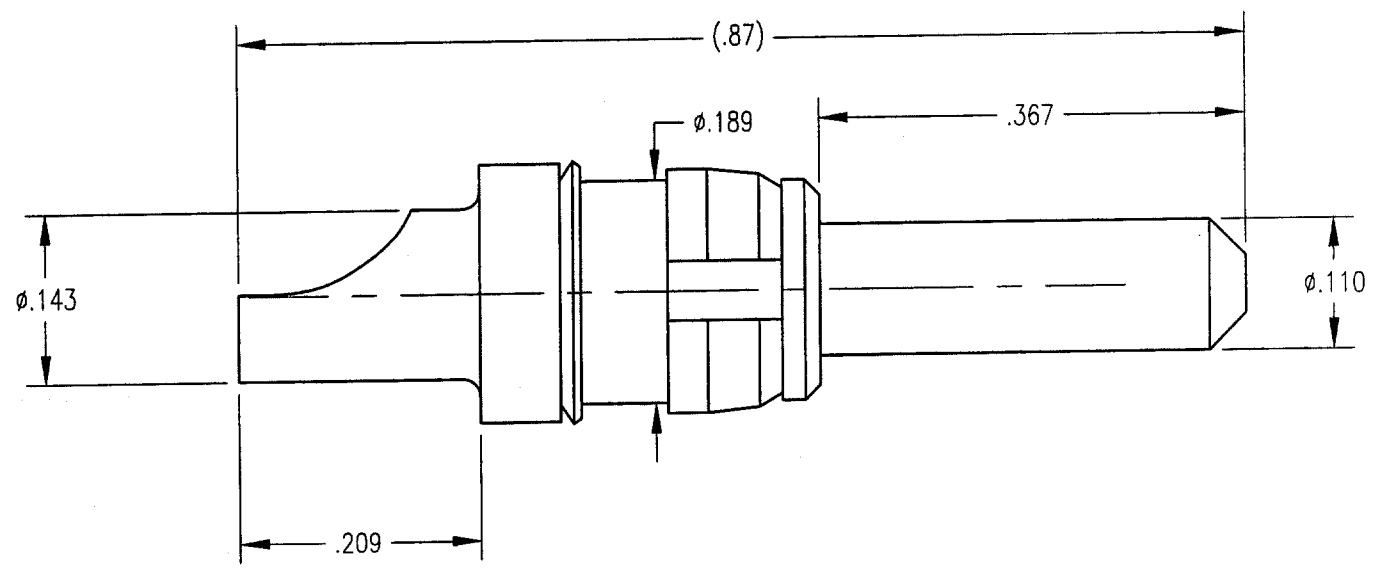

NOTES:

1. MATERIAL:
 BODY: BRASS PER ASTM B16
 SPRING WASHER: PHOSPHOR BRONZE PER ASTM B103
 CLIP RING: BERYLLIUM COPPER PER ASTM B194
2. FINISH:
 BODY: .000030 MIN. GOLD PER MIL-G-45204
 OVER .000050 MIN. NICKEL PER QQ-N-290
 WASHER: .000005 MIN. GOLD PER MIL-G-45204
 OVER .000050 MIN. NICKEL PER QQ-N-290
 CLIP RING: .000100 MIN NICKEL PER QQ-N-290
3. FOR USE WITH 12 AWG WIRE.

PER ASME Y14.5M-1994 UNLESS OTHERWISE SPECIFIED: DIMENSIONS ARE IN INCHES (MM)		Litton	
TOLERANCES: DECIMALS .xx ± .01/0.254 .xxx ± .005/0.127 ANGLES ± 2°		400 Park Road Watertown, Connecticut 06795	
CUSTOMER DRAWING		TITLE	
DRAWN EJW		RDM HIGH POWER PLUG 10/20 AMP	
DATE 1/7/98	CHECKED JMC	DATE 1/7/98	
APPROVED PRP	DATE 1/7/98	APPROVED PRP	DATE 1/7/98
A		220-510-0010G	SHT. OF REV. 1 1 A