

## FEATURES

- Complies With Universal Serial Bus Specification Rev. 2.0 (USB 2.0)
- Transmits and Receives Serial Data at Both Full-Speed (12-Mbit/s) and Low-Speed (1.5-Mbit/s) Data Rates
- Integrated Bypassable 5-V to 3.3-V Voltage Regulator for Powering Via USB VBUS
- Low-Power Operation, Ideal for Portable Equipment
- Meets the IEC-61000-4-2 Contact ( $\pm 9\text{KV}$ ) and Air-gap ( $\pm 9\text{KV}$ ) ESD Ratings
- Separate I/O Supply With Operation Down to 1.65 V
- Very-Low Power Consumption to Meet USB Suspend Current Requirements
- No Power-Supply Sequencing Requirements

## APPLICATIONS

- Cellular Phones
- Personal Digital Assistants (PDAs)
- Handheld Computers

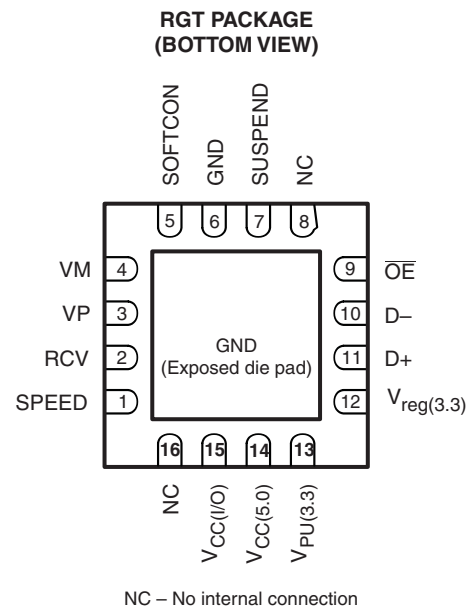
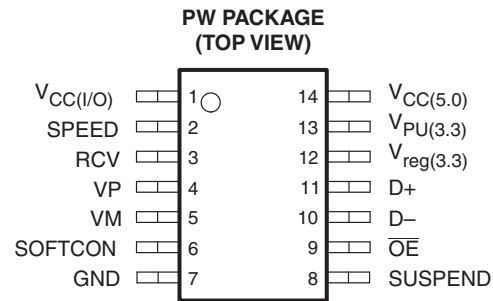

## DESCRIPTION/ORDERING INFORMATION

The TUSB2551 is a single-chip transceiver that complies with the physical-layer specifications of universal serial bus (USB) 2.0. The device supports both full-speed (12-Mbit/s) and low-speed (1.5-Mbit/s) operation. The TUSB2551 delivers superior edge rate control, producing crisper eye diagrams, which ease the task of passing USB compliance testing.

A dual supply-voltage operation allows the TUSB2551 to reference the system interface I/O signals to a supply voltage down to 1.6 V, while independently powered by the USB  $V_{CC(5.0)}$ . This allows the system interface to operate at its core voltage without the addition of buffering logic, and also reduce system operating current.

### ORDERING INFORMATION

T <sub>A</sub>	PACKAGE <sup>(1)(2)</sup>		ORDERABLE PART NUMBER	TOP-SIDE MARKING
	–40°C to 85°C	QFN – RGT		
TSSOP – PW		Reel of 3000	TUSB2551PWR	TU2551

(1) Package drawings, thermal data, and symbolization are available at [www.ti.com/packaging](http://www.ti.com/packaging).

(2) For the most current package and ordering information, see the Package Option Addendum at the end of this document, or see the TI website at [www.ti.com](http://www.ti.com).



Please be aware that an important notice concerning availability, standard warranty, and use in critical applications of Texas Instruments semiconductor products and disclaimers thereto appears at the end of this data sheet.

**BLOCK DIAGRAM**

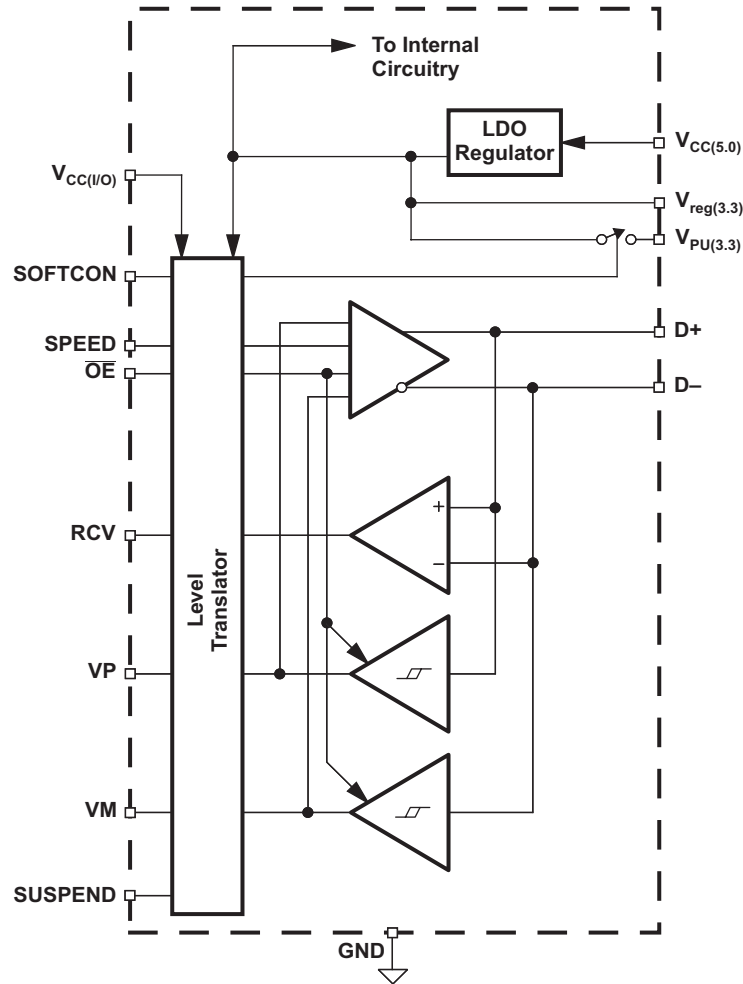

### TERMINAL FUNCTIONS

TERMINAL			I/O	DESCRIPTION
NAME	RGT NO.	PW NO.		
V <sub>CC(I/O)</sub>	15	1	I	System interface supply voltage. Used to provide reference supply voltage for system I/O interface signaling.
SPEED	1	2	I	Speed. Edge-rate control: A logic HIGH operates at edge rates for full-speed operation. A logic LOW operates at edge rates for low-speed operation.
RCV	2	3	O	Receive data. Output for USB differential data.
VP	3	4	I/O	If $\overline{OE} = 1$ , VP = Receiver output (+) If $\overline{OE} = 0$ , VP = Driver input (+)
VM	4	5	I/O	If $\overline{OE} = 1$ , VM = Receiver output (–) If $\overline{OE} = 0$ , VM = Driver input (–)
SOFTCON	5	6	I	Soft connect. Controls state of V <sub>PU(3.3)</sub> . Refer to V <sub>PU(3.3)</sub> pin description for details.
GND	6	7		Ground reference
SUSPEND	7	8	I	Suspend. Active high. Turns off internal circuits to reduce supply current.
NC	8, 16			No internal connection
$\overline{OE}$	9	9	I	Output enable. Active low. Enables the transceiver to transmit data onto the bus. When inactive, the transceiver is in the receive mode.
D–, D+	10, 11	10, 11	I/O	Differential data lines conforming to the USB standard
V <sub>reg(3.3)</sub>	12	12	O	3.3-V reference supply. Requires a minimum 0.1- $\mu$ F decoupling capacitor for stability. A 1- $\mu$ F capacitor is recommended.
V <sub>PU(3.3)</sub>	13	13	O	Pullup supply voltage. Used to connect 1.5-k $\Omega$ pullup speed detect resistor. If SOFTCON = 1, V <sub>PU(3.3)</sub> is high impedance. If SOFTCON = 0, V <sub>PU(3.3)</sub> = 3.3 V.
V <sub>CC(5.0)</sub>	14	14	I	USB bus supply voltage. Used to power USB transceiver and internal circuitry.

## FUNCTIONAL DESCRIPTION

### FUNCTION SELECTION

SUSPEND	$\overline{OE}$	D+, D–	RCV	VP, VM	FUNCTION
0	0	Driving	Active	Active	Normal transmit mode
0	1	Receiving	Active	Active	Normal receive mode
1	0	Hi-Z	0	Not active	Low power state
1	1	Hi-Z	0	Active	Receiving during suspend (low power state) <sup>(1)</sup>

(1) During suspend, VP and VM are active in order to detect out-of-band signaling conditions.

### TRUTH TABLE DURING NORMAL MODE

$\overline{OE} = 0$					
INPUT		OUTPUT			RESULT
VP	VM	D+	D–	RCV	
0	0	0	0	X <sup>(1)</sup>	SE0
0	1	0	1	0	Logic 0
1	0	1	0	1	Logic 1
1	1	1	1	X <sup>(1)</sup>	Undefined
$\overline{OE} = 1$					
Input		Output			RESULT
D+	D–	VP	VM	RCV	
0	0	0	0	X <sup>(1)</sup>	SE0
0	1	0	1	0	Logic 0
1	0	1	0	1	Logic 1
1	1	1	1	X <sup>(1)</sup>	Undefined

(1) X = Undefined

## Power-Supply Configurations

The TUSB2551 can be used with different power-supply configurations, which can be dynamically changed. An overview is given in [Table 1](#).

- Normal mode – Both  $V_{CC(I/O)}$  and  $V_{CC(5.0)}$  or  $V_{CC(5.0)}$  and  $V_{reg(3.3)}$  are connected. For 5-V operation,  $V_{CC(5.0)}$  is connected to a 5-V source (4 V to 5.5 V). The internal voltage regulator then produces 3.3 V for the USB connections. For 3.3-V operation, both  $V_{CC(5.0)}$  and  $V_{reg(3.3)}$  are connected to a 3.3-V source (3 V to 3.6 V).  $V_{CC(I/O)}$  is independently connected to a voltage source (1.65 V to 3.6 V), depending on the supply voltage of the external circuit.
- Disable mode –  $V_{CC(I/O)}$  is not connected;  $V_{CC(5.0)}$  or  $V_{CC(5.0)}$  and  $V_{reg(3.3)}$  are connected. In this mode, the internal circuits of the TUSB2551 ensure that the D+ and D– pins are in 3-state, and the power consumption drops to the low-power (suspended) state level. Some hysteresis is built into the detection of  $V_{CC(I/O)}$  lost.
- Sharing mode –  $V_{CC(I/O)}$  is connected;  $V_{CC(5.0)}$  and  $V_{reg(3.3)}$  are not connected. In this mode, the D+ and D– pins are made 3-state, and the TUSB2551 allows external signals of up to 3.6 V to share the D+ and D– lines. The internal circuits of the TUSB2551 ensure that virtually no current (maximum 10 mA) is drawn via the D+ and D– lines. The power consumption through  $V_{CC(I/O)}$  drops to the low-power (suspended) state level. Both the VP and VM pins are driven HIGH to indicate this mode. Pin RCV is made LOW. Some hysteresis is built into the detection of  $V_{reg(3.3)}$  lost.

**Table 1. Power-Supply Configuration Overview**

Configuration Mode	VBUS/VTRM	VIF	Notes
Normal	Connected	Connected	Normal supply configuration and operation.
Disconnect (D+/D– sharing)	Open	Connected	VP/VM are HIGH outputs, RCV is LOW. With OE# = 0 and SUSPEND = 1, data lines may be driven with external devices up to 3.6 V. With D+, D– floating, $I_{CC(I/O)}$ draws less than 1 $\mu$ A.
Disconnect	Ground	Connected	VP/VM are HIGH outputs, RCV is LOW. With D+, D– floating, $I_{CC(I/O)F}$ draws less than 1 $\mu$ A.
Disable Mode	Connected	Open	Logic controlled inputs pins are Hi-Z
Prohibited	Connected	Ground	Prohibited condition

**Table 2. Pin States in Disable or Sharing Mode**

PINS	DISABLE-MODE STATE	SHARING-MODE STATE
$V_{CC(5.0)}/V_{reg(3.3)}$	5-V input/3.3-V output, 3.3-V input/3.3-V input	Not present
$V_{CC(I/O)}$	Not present	1.65-V to 3.6-V input
$V_{PU(3.3)}$	High impedance (off)	High impedance (off)
D+, D–	High impedance	High impedance
VP, VM	Invalid <sup>(1)</sup>	H
RCV	Invalid <sup>(1)</sup>	L
Inputs (SPEED, SUSPEND, $\overline{OE}$ , SOFTCON)	High impedance	High impedance

(1) High impedance or driven LOW

## Power-Supply Input Options

The TUSB2551 has two power-supply input options.

- Internal regulator –  $V_{CC(5.0)}$  is connected to 4 V to 5.5 V. The internal regulator is used to supply the internal circuitry with 3.3 V (nominal).  $V_{reg(3.3)}$  becomes a 3.3-V output reference.
- Regulator bypass –  $V_{CC(5.0)}$  and  $V_{reg(3.3)}$  are connected to the same supply. The internal regulator is bypassed, and the internal circuitry is supplied directly from the  $V_{reg(3.3)}$  power supply. The voltage range is 3 V to 3.6 V to comply with the USB specification.

The supply-voltage range for each input option is specified in [Table 3](#).

**Table 3. Power-Supply Input Options**

INPUT OPTION	$V_{CC(5.0)}$	$V_{reg(3.3)}$	$V_{CC(I/O)}$
Internal regulator	Supply input for internal regulator (4 V to 5.5 V)	Voltage-reference output (3.3 V, 300 $\mu$ A)	Supply input for digital I/O pins (1.4 V to 3.6 V)
Regulator bypass	Connected to $V_{reg(3.3)}$ with maximum voltage drop of 0.3 V (2.7 V to 3.6 V)	Supply input (3 V to 3.6 V)	Supply input for digital I/O pins (1.4 V to 3.6 V)

## Electrostatic Discharge (ESD)

PIN NAME	ESD	TYP	UNIT
D+, D–, $V_{CC(5.0)}$	IEC61000-4-2, Air-Gap Discharge	$\pm 9$	kV
	IEC61000-4-2, Contact Discharge	$\pm 9$	
	Human-Body Model	$\pm 15$	
All other pins	Human-Body Model	$\pm 2$	kV

# TUSB2551

## ADVANCED UNIVERSAL SERIAL BUS TRANSCEIVER

SCES667–FEBRUARY 2008

### ABSOLUTE MAXIMUM RATINGS<sup>(1)</sup>

over operating free-air temperature range (unless otherwise noted)

		MIN	MAX	UNIT
$V_{CC(5.0)}$	Supply voltage range	-0.5	6	V
$V_{CC(I/O)}$	I/O supply voltage range	-0.5	4.6	V
$V_{reg(3.3)}$	Regulated voltage range	-0.5	4.6	V
$V_I$	DC input voltage range	-0.5	$V_{CC(I/O)} + 0.5$	mA
$I_{O(D+, D-)}$	Output Current (D+, D-)		±50	mA
$I_O$	Output Current (all others)		±15	mA
$I_I$	Input Current		±50	mA
$T_{stg}$	Storage temperature range	-65	150	°C

(1) Stresses beyond those listed under "absolute maximum ratings" may cause permanent damage to the device. These are stress ratings only, and functional operation of the device at these or any other conditions beyond those indicated under "recommended operating conditions" is not implied. Exposure to absolute-maximum-rated conditions for extended periods may affect device reliability.

### RECOMMENDED OPERATING CONDITIONS

PARAMETER	TEST CONDITIONS	MIN	TYP	MAX	UNIT	
$V_{CC(5.0)}$	Supply voltage, internal regulator option	5-V operation	4	5	5.25	V
$V_{reg(3.3)}$	Supply voltage, regulator bypass option	3.3-V operation	3	3.3	3.6	V
$V_{CC(I/O)}$	I/O supply voltage		1.65		3.6	V
$V_{IL}$	Low-level input voltage <sup>(1)</sup>		$V_{CC(I/O)} - 0.3$		$0.15 V_{CC(I/O)}$	V
$V_{IH}$	High-level input voltage <sup>(1)</sup>		$0.85 V_{CC(I/O)}$		$V_{CC(I/O)} + 0.3$	V
D+, D-	Input voltage on analog I/O pins		0		3.6	V
$T_c$	Junction temperature range		-40		85	°C

(1) Specification applies to the following pins: SUSPEND, SPEED, RCV, SOFTCON, VP, VM,  $\overline{OE}$

**DC ELECTRICAL CHARACTERISTICS SYSTEM AND USB INTERFACE<sup>(1)</sup>**

$V_{CC(I/O)} = 3.6\text{ V}$ ,  $V_{CC(5.0)} = 5\text{ V}$  (unless otherwise noted),  $T_A = 25\text{ }^{\circ}\text{C}$ . Bold indicates specifications over temperature,  $-40^{\circ}\text{C}$  to  $85^{\circ}\text{C}$

PARAMETER		TEST CONDITIONS					MIN	TYP	MAX	UNIT	
$V_{OH}$	High-level output voltage <sup>(2)</sup>	$I_{OH} = 20\text{ }\mu\text{A}$					$0.9 V_{CC(I/O)}$			V	
$V_{OL}$	Low-level output voltage <sup>(2)</sup>	$I_{OL} = 20\text{ }\mu\text{A}$								V	
$I_{IL}$	Input leakage current <sup>(2)</sup>						-5	1.5	5	$\mu\text{A}$	
$I_{CC(I/O)}$	$V_{CC(I/O)}$ supply current	<b>SPEED</b>	<b>SUSPEND</b>	<b><math>\overline{OE}</math></b>	<b>VOLTAGE</b>	<b>LOAD</b>					
		1	0	1			$V_{CC(5.0)} = 5.25\text{ V}$ , $V_{CC(I/O)} = 3.6\text{ V}$		1	5	$\mu\text{A}$
		1	0	0					1	5	
		0	0	1					1	5	
		0	0	0					1	5	
		0	1	0					1	5	
		1	0	0				f = 6 MHz, $C_L = 50\text{ pF}$	1	2	
		0	0	0			f = 750 kHz, $C_L = 600\text{ pF}$	260	280	$\mu\text{A}$	
$I_{CC(5.0)}$	$V_{CC(5.0)}$ supply current	1	0	1	$V_{CC(5.0)} = 5.25\text{ V}$ , $V_{CC(I/O)} = 3.6\text{ V}$		800	1100	$\mu\text{A}$		
		1	0	0			3000	5000			
		0	0	1			230	350			
		0	0	0			400	700			
		0	1	0			130	200			
		1	0	0		f = 6 MHz, $C_L = 50\text{ pF}$	6	10		mA	
		0	0	0		f = 750 kHz, $C_L = 600\text{ pF}$	4.3	5			
		$I_{PU(3.3)LEAK}$	$V_{PU(3.3)}$ leakage current	SOFTCON = 1, $V_{PU(3.3)} = 0\text{ V}$					-5		5
$I_{CC(I/O)LEAK}$	$V_{CC(I/O)}$ leakage current	$V_{CC(I/O)} = 3.6\text{ V}$ , $V_{CC(5.0)} = 0\text{ V}$					-5		5	$\mu\text{A}$	
$V_{PU(3.3)}$	Pullup output voltage	$I_{reg(3.3)} = 200\text{ }\mu\text{A}$ , $V_{CC(5.0)} = 4\text{ V to }5.25\text{ V}$					3	3.3	3.6	V	
$R_{SW}$	$V_{PU(3.3)}$ switch resistance	$I_{reg(3.3)} = 10\text{ mA}$ , $V_{CC(5.0)} = 4\text{ V to }5.25\text{ V}$						10		$\Omega$	
<b>ESD PROTECTION</b>											
IEC-61000-4-2 (D+, D-, $V_{CC(5.0)}$ only)	Air-Gap Discharge	10 pulses						$\pm 9$		kV	
	Contact Discharge	10 pulses						$\pm 9$			

(1) Specification for packaged product only

(2) Specification applies to the following pins: RCV, VP, VM,  $\overline{OE}$ .

# TUSB2551 ADVANCED UNIVERSAL SERIAL BUS TRANSCEIVER

SCES667–FEBRUARY 2008



## DC ELECTRICAL CHARACTERISTICS TRANSCEIVER<sup>(1)</sup>

PARAMETER		TEST CONDITIONS	MIN	TYP	MAX	UNIT
<b>LEAKAGE CURRENT</b>						
$I_{LO}$	Hi-Z state data line leakage (suspend mode)	$0\text{ V} < V_{IN} < 3.3\text{ V}$ , SUSPEND = 1	-10		10	$\mu\text{A}$
<b>INPUT LEVELS</b>						
$V_{DI}$	Differential input sensitivity	$ (D+) - (D-) $	0.2			V
$V_{CM}$	Differential common mode range	Includes $V_{DI}$ range	0.8		2.5	V
$V_{SE}$	Single-ended receiver threshold		0.8		2	V
	Receiver hysteresis			200		mV
<b>OUTPUT LEVELS</b>						
$V_{OL}$	Static output low	$R_L = 1.5\text{ k}\Omega$ to $3.6\text{ V}$			0.3	V
$V_{OH}$	Static output high	$R_L = 15\text{ k}\Omega$ to GND	2.8		3.6	V
<b>CAPACITANCE</b>						
$C_{IN}$	Transceiver capacitance	Pin to GND		10		pF
$Z_{DRV}$	Driver output resistance	Steady-state drive	1	6	11	$\Omega$

(1) Specification for packaged product only

**AC ELECTRICAL CHARACTERISTICS<sup>(1)</sup>**

PARAMETER		TEST CONDITIONS	MIN	MAX	UNIT
<b>DRIVER CHARACTERISTICS (LOW SPEED)</b>					
$T_R$	Transition rise time	$C_L = 200$ pF, See <a href="#">Figure 2</a> $C_L = 600$ pF	75	300	ns
$T_F$	Transition fall time	$C_L = 200$ pF, See <a href="#">Figure 2</a> $C_L = 600$ pF	75	300	ns
LRFM	Rise/fall time matching	$T_R, T_F$	80	125	%
$V_{CRS}$	Output signal crossover voltage		1.3	2	V
<b>DRIVER CHARACTERISTICS (FULL SPEED)</b>					
$T_R$	Transition rise time	$C_L = 50$ pF, See <a href="#">Figure 2</a>	4	20	ns
$T_F$	Transition fall time	$C_L = 50$ pF, <a href="#">Figure 2</a>	4	20	ns
FRFM	Rise/fall time matching	( $T_R, T_F$ )	90	111.1	%
$V_{CRS}$	Output signal crossover voltage		1.3	2	V
<b>TRANSCEIVER TIMING (FULL SPEED)</b>					
$t_{PVZ}$	$\overline{OE}$ to receiver 3-state delay	See <a href="#">Figure 1</a>		15	ns
$t_{PZD}$	Receiver 3-state to transmit delay	See <a href="#">Figure 1</a>	15		ns
$t_{PDZ}$	$\overline{OE}$ to driver 3-state delay	See <a href="#">Figure 1</a>		15	ns
$t_{PZV}$	Driver 3-state to receive delay	See <a href="#">Figure 1</a>	15		ns
$t_{PLH}$ $t_{PHL}$	$V_P, V_M$ to D+, D– propagation delay	See <a href="#">Figure 4</a>		17	ns
$t_{PLH}$ $t_{PHL}$	D+, D– to RCV propagation delay	See <a href="#">Figure 3</a>		17	ns
$t_{PLH}$ $t_{PHL}$	D+, D– to $V_P, V_M$ propagation delay	See <a href="#">Figure 3</a>		10	ns

(1) Specification for packaged product only

TIMING DIAGRAMS

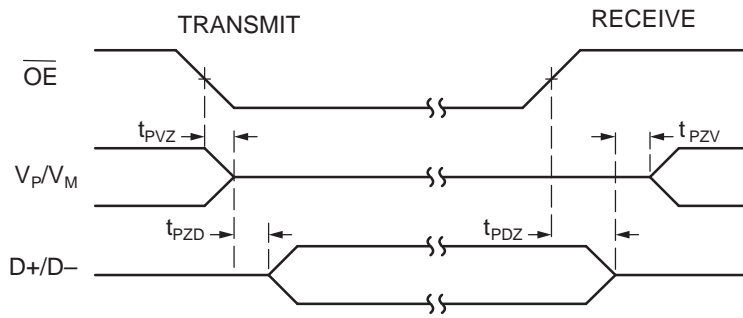

Figure 1. Enable and Disable Times

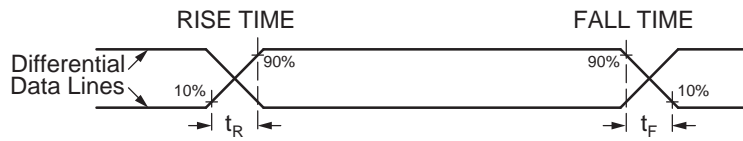

Figure 2. Rise and Fall Times

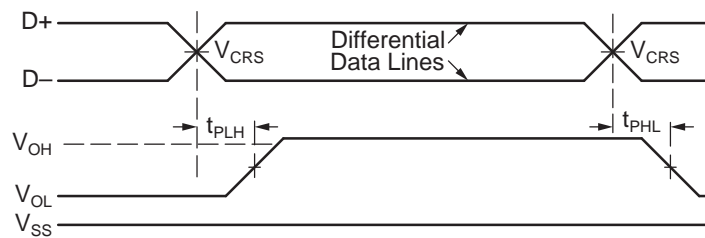

Figure 3. Receiver Propagation Delay

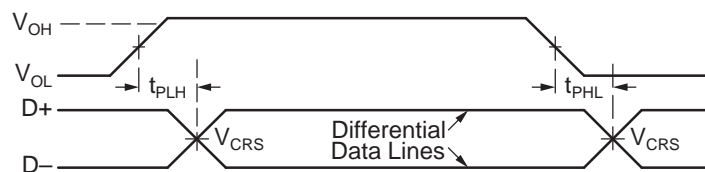

Figure 4. Driver Propagation Delay

TEST CIRCUITS

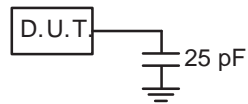

Figure 5. Load for  $V_P$ ,  $V_M$ , RCV

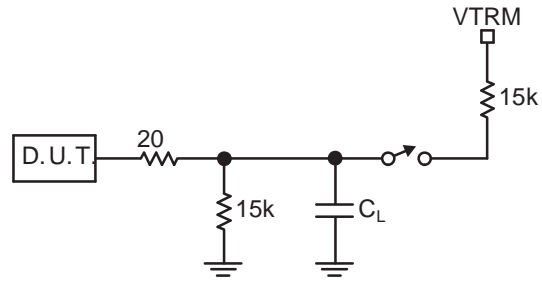

Figure 6. Load for  $D_+$ ,  $D_-$

**PACKAGING INFORMATION**

Orderable Device	Status <sup>(1)</sup>	Package Type	Package Drawing	Pins	Package Qty	Eco Plan <sup>(2)</sup>	Lead/ Ball Finish	MSL Peak Temp <sup>(3)</sup>	Samples (Requires Login)
TUSB2551PW	NRND	TSSOP	PW	14	90	Green (RoHS & no Sb/Br)	CU NIPDAU	Level-1-260C-UNLIM	Samples Not Available
TUSB2551PWG4	NRND	TSSOP	PW	14	90	Green (RoHS & no Sb/Br)	CU NIPDAU	Level-1-260C-UNLIM	Samples Not Available
TUSB2551PWR	NRND	TSSOP	PW	14	2000	Green (RoHS & no Sb/Br)	CU NIPDAU	Level-1-260C-UNLIM	Samples Not Available
TUSB2551PWRG4	NRND	TSSOP	PW	14	2000	Green (RoHS & no Sb/Br)	CU NIPDAU	Level-1-260C-UNLIM	Samples Not Available
TUSB2551RGTR	NRND	QFN	RGT	16	3000	TBD	Call TI	Call TI	Samples Not Available

<sup>(1)</sup> The marketing status values are defined as follows:

**ACTIVE:** Product device recommended for new designs.

**LIFEBUY:** TI has announced that the device will be discontinued, and a lifetime-buy period is in effect.

**NRND:** Not recommended for new designs. Device is in production to support existing customers, but TI does not recommend using this part in a new design.

**PREVIEW:** Device has been announced but is not in production. Samples may or may not be available.

**OBSELETE:** TI has discontinued the production of the device.

<sup>(2)</sup> Eco Plan - The planned eco-friendly classification: Pb-Free (RoHS), Pb-Free (RoHS Exempt), or Green (RoHS & no Sb/Br) - please check <http://www.ti.com/productcontent> for the latest availability information and additional product content details.

**TBD:** The Pb-Free/Green conversion plan has not been defined.

**Pb-Free (RoHS):** TI's terms "Lead-Free" or "Pb-Free" mean semiconductor products that are compatible with the current RoHS requirements for all 6 substances, including the requirement that lead not exceed 0.1% by weight in homogeneous materials. Where designed to be soldered at high temperatures, TI Pb-Free products are suitable for use in specified lead-free processes.

**Pb-Free (RoHS Exempt):** This component has a RoHS exemption for either 1) lead-based flip-chip solder bumps used between the die and package, or 2) lead-based die adhesive used between the die and leadframe. The component is otherwise considered Pb-Free (RoHS compatible) as defined above.

**Green (RoHS & no Sb/Br):** TI defines "Green" to mean Pb-Free (RoHS compatible), and free of Bromine (Br) and Antimony (Sb) based flame retardants (Br or Sb do not exceed 0.1% by weight in homogeneous material)

<sup>(3)</sup> MSL, Peak Temp. -- The Moisture Sensitivity Level rating according to the JEDEC industry standard classifications, and peak solder temperature.

**Important Information and Disclaimer:** The information provided on this page represents TI's knowledge and belief as of the date that it is provided. TI bases its knowledge and belief on information provided by third parties, and makes no representation or warranty as to the accuracy of such information. Efforts are underway to better integrate information from third parties. TI has taken and continues to take reasonable steps to provide representative and accurate information but may not have conducted destructive testing or chemical analysis on incoming materials and chemicals. TI and TI suppliers consider certain information to be proprietary, and thus CAS numbers and other limited information may not be available for release.

In no event shall TI's liability arising out of such information exceed the total purchase price of the TI part(s) at issue in this document sold by TI to Customer on an annual basis.

## TAPE AND REEL INFORMATION

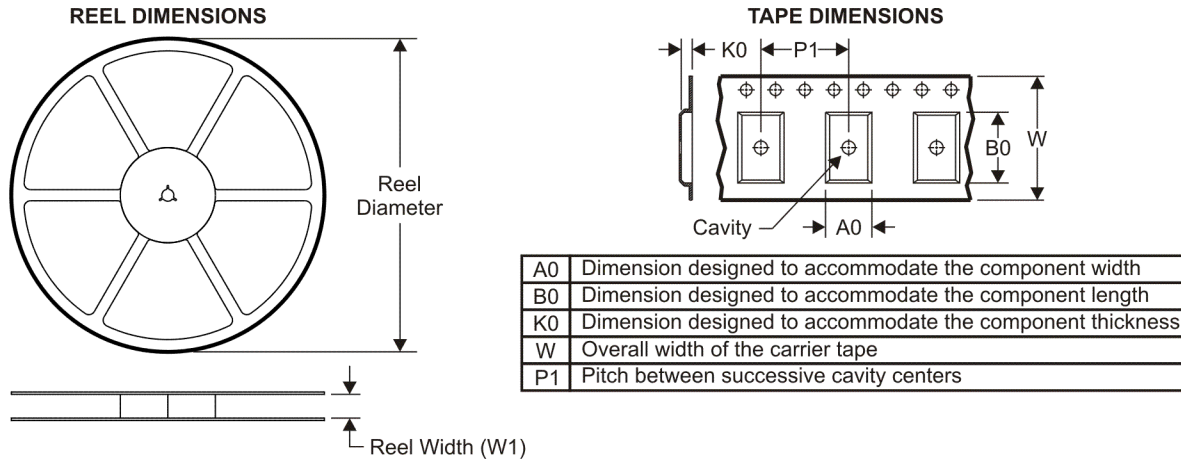

### QUADRANT ASSIGNMENTS FOR PIN 1 ORIENTATION IN TAPE



\*All dimensions are nominal

Device	Package Type	Package Drawing	Pins	SPQ	Reel Diameter (mm)	Reel Width W1 (mm)	A0 (mm)	B0 (mm)	K0 (mm)	P1 (mm)	W (mm)	Pin1 Quadrant
TUSB2551PWR	TSSOP	PW	14	2000	330.0	12.4	6.9	5.6	1.6	8.0	12.0	Q1

TAPE AND REEL BOX DIMENSIONS



\*All dimensions are nominal

Device	Package Type	Package Drawing	Pins	SPQ	Length (mm)	Width (mm)	Height (mm)
TUSB2551PWR	TSSOP	PW	14	2000	346.0	346.0	29.0

RGT (S-PVQFN-N16)

PLASTIC QUAD FLATPACK NO-LEAD

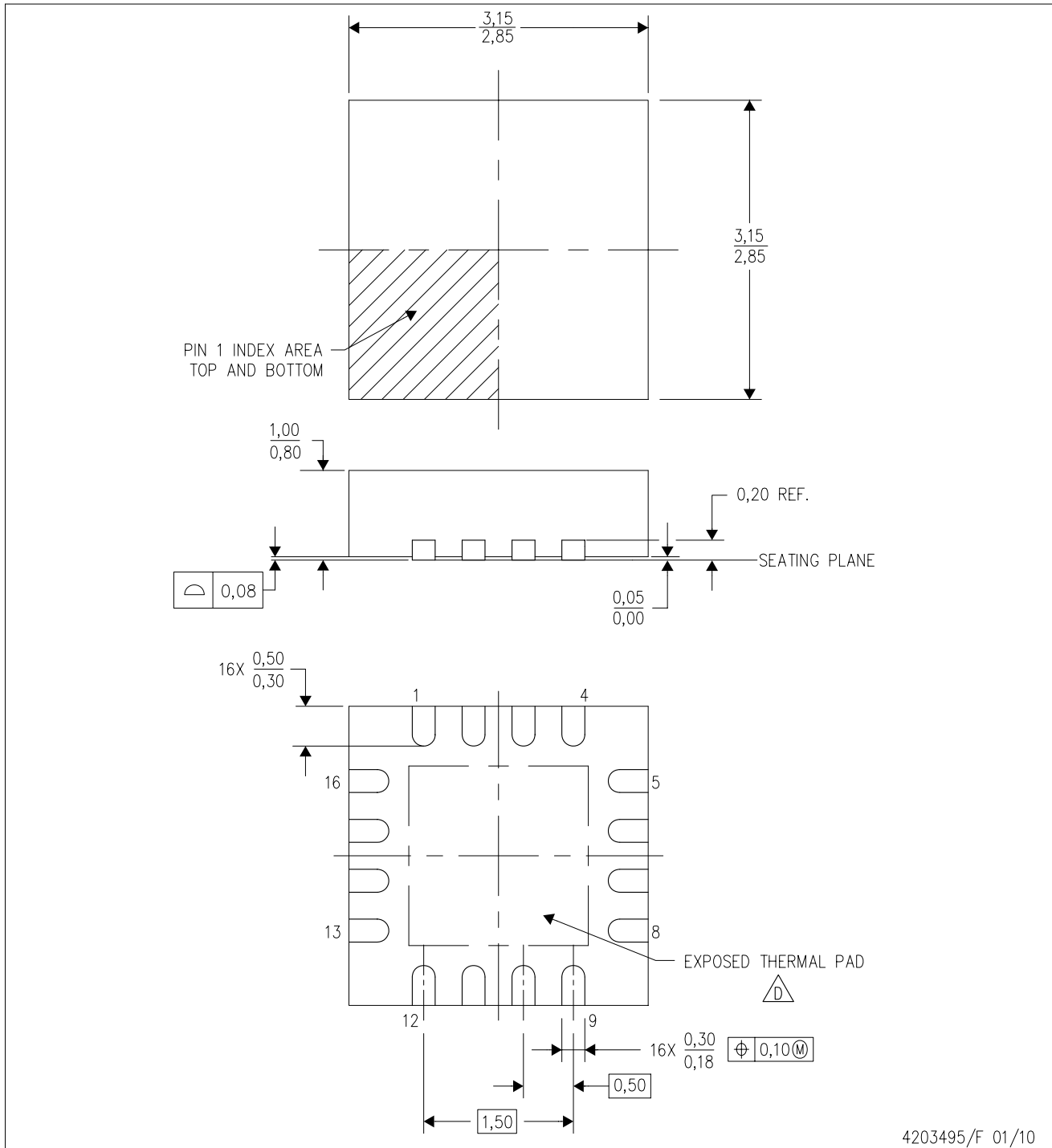

4203495/F 01/10

- NOTES:
- A. All linear dimensions are in millimeters. Dimensioning and tolerancing per ASME Y14.5M-1994.
  - B. This drawing is subject to change without notice.
  - C. Quad Flatpack, No-leads (QFN) package configuration.
  -  The package thermal pad must be soldered to the board for thermal and mechanical performance. See the Product Data Sheet for details regarding the exposed thermal pad dimensions.
  - E. Falls within JEDEC MO-220.

## THERMAL PAD MECHANICAL DATA

RGT (S-PVQFN-N16)

PLASTIC QUAD FLATPACK NO-LEAD

### THERMAL INFORMATION

This package incorporates an exposed thermal pad that is designed to be attached directly to an external heatsink. The thermal pad must be soldered directly to the printed circuit board (PCB). After soldering, the PCB can be used as a heatsink. In addition, through the use of thermal vias, the thermal pad can be attached directly to the appropriate copper plane shown in the electrical schematic for the device, or alternatively, can be attached to a special heatsink structure designed into the PCB. This design optimizes the heat transfer from the integrated circuit (IC).

For information on the Quad Flatpack No-Lead (QFN) package and its advantages, refer to Application Report, QFN/SON PCB Attachment, Texas Instruments Literature No. SLUA271. This document is available at [www.ti.com](http://www.ti.com).

The exposed thermal pad dimensions for this package are shown in the following illustration.

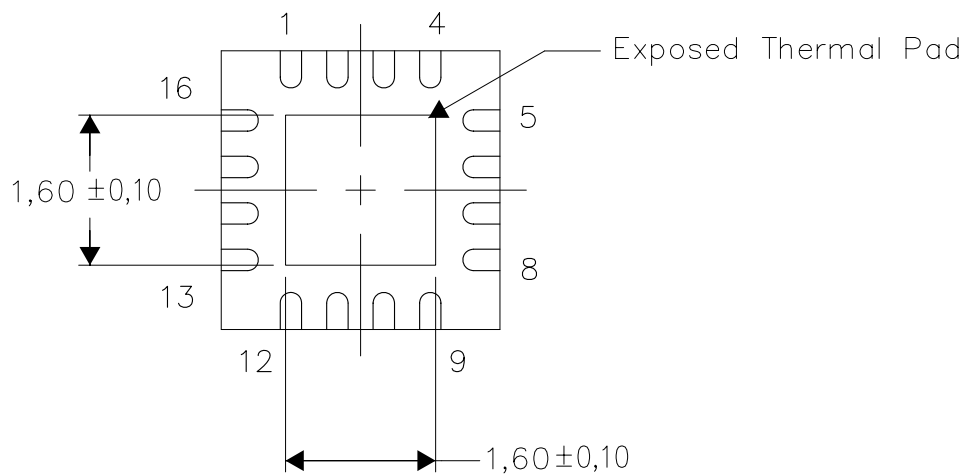

Bottom View

Exposed Thermal Pad Dimensions

4206349-3/N 08/10

NOTE: A. All linear dimensions are in millimeters

RGT (S-PVQFN-N16)

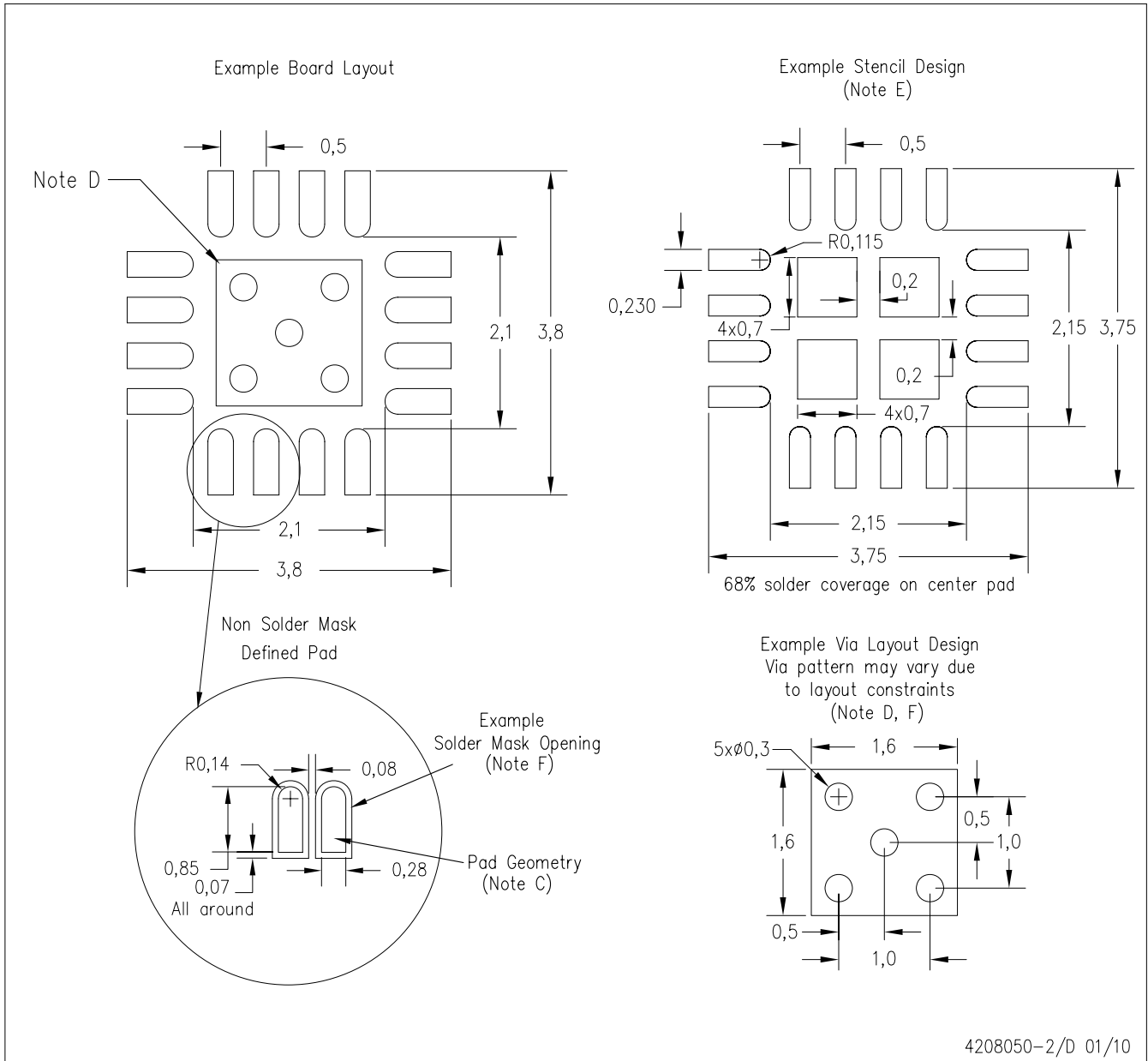

- NOTES:
- A. All linear dimensions are in millimeters.
  - B. This drawing is subject to change without notice.
  - C. Publication IPC-7351 is recommended for alternate designs.
  - D. This package is designed to be soldered to a thermal pad on the board. Refer to Application Note, QFN/SON PCB Attachment, Texas Instruments Literature No. SLUA271, and also the Product Data Sheets for specific thermal information, via requirements, and recommended board layout. These documents are available at [www.ti.com](http://www.ti.com) <<http://www.ti.com>>.
  - E. Laser cutting apertures with trapezoidal walls and also rounding corners will offer better paste release. Customers should contact their board assembly site for stencil design recommendations. Refer to IPC 7525 for stencil design considerations.
  - F. Customers should contact their board fabrication site for minimum solder mask web tolerances between signal pads.

PW (R-PDSO-G\*\*)

PLASTIC SMALL-OUTLINE PACKAGE

14 PINS SHOWN



4040064/F 01/97

- NOTES: A. All linear dimensions are in millimeters.  
 B. This drawing is subject to change without notice.  
 C. Body dimensions do not include mold flash or protrusion not to exceed 0,15.  
 D. Falls within JEDEC MO-153

PW (R-PDSO-G14)

PLASTIC SMALL OUTLINE

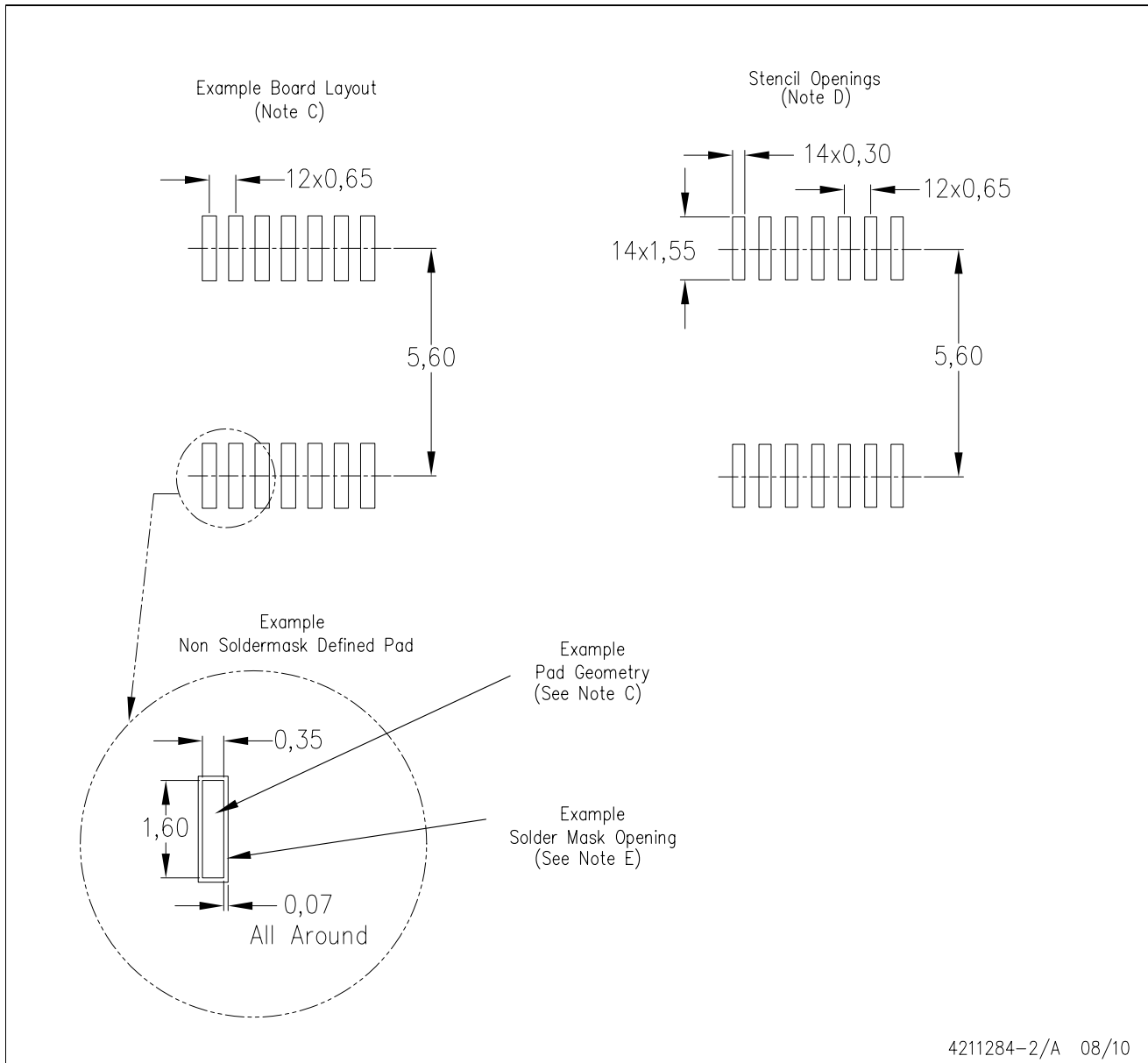

- NOTES:
- All linear dimensions are in millimeters.
  - This drawing is subject to change without notice.
  - Publication IPC-7351 is recommended for alternate designs.
  - Laser cutting apertures with trapezoidal walls and also rounding corners will offer better paste release. Customers should contact their board assembly site for stencil design recommendations. Refer to IPC-7525 for other stencil recommendations.
  - Customers should contact their board fabrication site for solder mask tolerances between and around signal pads.

## IMPORTANT NOTICE

Texas Instruments Incorporated and its subsidiaries (TI) reserve the right to make corrections, modifications, enhancements, improvements, and other changes to its products and services at any time and to discontinue any product or service without notice. Customers should obtain the latest relevant information before placing orders and should verify that such information is current and complete. All products are sold subject to TI's terms and conditions of sale supplied at the time of order acknowledgment.

TI warrants performance of its hardware products to the specifications applicable at the time of sale in accordance with TI's standard warranty. Testing and other quality control techniques are used to the extent TI deems necessary to support this warranty. Except where mandated by government requirements, testing of all parameters of each product is not necessarily performed.

TI assumes no liability for applications assistance or customer product design. Customers are responsible for their products and applications using TI components. To minimize the risks associated with customer products and applications, customers should provide adequate design and operating safeguards.

TI does not warrant or represent that any license, either express or implied, is granted under any TI patent right, copyright, mask work right, or other TI intellectual property right relating to any combination, machine, or process in which TI products or services are used. Information published by TI regarding third-party products or services does not constitute a license from TI to use such products or services or a warranty or endorsement thereof. Use of such information may require a license from a third party under the patents or other intellectual property of the third party, or a license from TI under the patents or other intellectual property of TI.

Reproduction of TI information in TI data books or data sheets is permissible only if reproduction is without alteration and is accompanied by all associated warranties, conditions, limitations, and notices. Reproduction of this information with alteration is an unfair and deceptive business practice. TI is not responsible or liable for such altered documentation. Information of third parties may be subject to additional restrictions.

Resale of TI products or services with statements different from or beyond the parameters stated by TI for that product or service voids all express and any implied warranties for the associated TI product or service and is an unfair and deceptive business practice. TI is not responsible or liable for any such statements.

TI products are not authorized for use in safety-critical applications (such as life support) where a failure of the TI product would reasonably be expected to cause severe personal injury or death, unless officers of the parties have executed an agreement specifically governing such use. Buyers represent that they have all necessary expertise in the safety and regulatory ramifications of their applications, and acknowledge and agree that they are solely responsible for all legal, regulatory and safety-related requirements concerning their products and any use of TI products in such safety-critical applications, notwithstanding any applications-related information or support that may be provided by TI. Further, Buyers must fully indemnify TI and its representatives against any damages arising out of the use of TI products in such safety-critical applications.

TI products are neither designed nor intended for use in military/aerospace applications or environments unless the TI products are specifically designated by TI as military-grade or "enhanced plastic." Only products designated by TI as military-grade meet military specifications. Buyers acknowledge and agree that any such use of TI products which TI has not designated as military-grade is solely at the Buyer's risk, and that they are solely responsible for compliance with all legal and regulatory requirements in connection with such use.

TI products are neither designed nor intended for use in automotive applications or environments unless the specific TI products are designated by TI as compliant with ISO/TS 16949 requirements. Buyers acknowledge and agree that, if they use any non-designated products in automotive applications, TI will not be responsible for any failure to meet such requirements.

Following are URLs where you can obtain information on other Texas Instruments products and application solutions:

<b>Products</b>		<b>Applications</b>	
Amplifiers	<a href="http://amplifier.ti.com">amplifier.ti.com</a>	Audio	<a href="http://www.ti.com/audio">www.ti.com/audio</a>
Data Converters	<a href="http://dataconverter.ti.com">dataconverter.ti.com</a>	Automotive	<a href="http://www.ti.com/automotive">www.ti.com/automotive</a>
DLP® Products	<a href="http://www.dlp.com">www.dlp.com</a>	Communications and Telecom	<a href="http://www.ti.com/communications">www.ti.com/communications</a>
DSP	<a href="http://dsp.ti.com">dsp.ti.com</a>	Computers and Peripherals	<a href="http://www.ti.com/computers">www.ti.com/computers</a>
Clocks and Timers	<a href="http://www.ti.com/clocks">www.ti.com/clocks</a>	Consumer Electronics	<a href="http://www.ti.com/consumer-apps">www.ti.com/consumer-apps</a>
Interface	<a href="http://interface.ti.com">interface.ti.com</a>	Energy	<a href="http://www.ti.com/energy">www.ti.com/energy</a>
Logic	<a href="http://logic.ti.com">logic.ti.com</a>	Industrial	<a href="http://www.ti.com/industrial">www.ti.com/industrial</a>
Power Mgmt	<a href="http://power.ti.com">power.ti.com</a>	Medical	<a href="http://www.ti.com/medical">www.ti.com/medical</a>
Microcontrollers	<a href="http://microcontroller.ti.com">microcontroller.ti.com</a>	Security	<a href="http://www.ti.com/security">www.ti.com/security</a>
RFID	<a href="http://www.ti-rfid.com">www.ti-rfid.com</a>	Space, Avionics & Defense	<a href="http://www.ti.com/space-avionics-defense">www.ti.com/space-avionics-defense</a>
RF/IF and ZigBee® Solutions	<a href="http://www.ti.com/lprf">www.ti.com/lprf</a>	Video and Imaging	<a href="http://www.ti.com/video">www.ti.com/video</a>
		Wireless	<a href="http://www.ti.com/wireless-apps">www.ti.com/wireless-apps</a>

Mailing Address: Texas Instruments, Post Office Box 655303, Dallas, Texas 75265  
Copyright © 2010, Texas Instruments Incorporated