

Everlight EZHV 1W LED Series

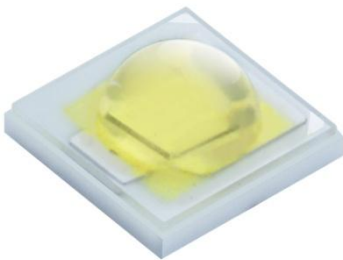

Introduction

The High Voltage (HV) LED is a surface-mount high voltage component featuring compact size, high brightness, and DC input voltage that more closely resembles the V_{rms} of AC mains voltage. This allows for simple lighting fixture designs that do not require full convertor and driver solutions – dramatically reducing the total design costs while increasing total fixture efficiency. Being one of the first of its kind, the Everlight HV LED will be a viable solution for all future lighting designs and is ready to face the challenges of today's Solid-State Lighting requirements.

Description

- ◆ Small package with high efficiency
- ◆ ESD protection up to 2KV
- ◆ Soldering method: SMT
- ◆ Moisture Sensitivity Level: 1
- ◆ RoHS compliant
- ◆ Matches ANSI binning
- ◆ Binning Parameters: Brightness, Forward Voltage, Wavelength and Chromaticity

Applications

- ◆ General Lighting
- ◆ Indoor Lighting
- ◆ Street Lighting
- ◆ Retrofits

Table of Content

Table of Content.....	2
Product Nomenclature	3
Absolute Maximum Ratings (Ts=25°C).....	4
JEDEC Moisture Sensitivity	4
Luminous Flux Characteristics for the EZHV 1W series	5
PN of the EZHV 1W series : White LEDs.....	6
Product Binning.....	7
Forward Voltage Bins	14
Mechanical Dimension	15
Pad Configuration	16
Reflow Soldering Characteristics	17
Typical Wavelength Characteristics	18
Typical Light Output Characteristic vs. Thermal Pad Temperature.....	19
Typical Relative Luminous Flux vs. Forward Current	19
Typical Electrical Characteristics.....	20
Typical CCT Shift Characteristics vs. Forward Current	20
Typical Radiation Patterns	22
Typical Difference of CIE of Cool-White vs. Angle.....	23
Typical Difference of CIE of Warm-White vs. Angle	23
Emitter Tape Packaging	24
Emitter Reel Packaging.....	25
Product Labeling	25
Storage Conditions.....	26
Revision History	27

Product Nomenclature

The product name is designated as below:

EZHV- ABCDE – FGHIJ – V1234

Designation:

AB = min. luminous flux (lm) or radiation power (mW) performance

C = radiation pattern [1]

D = color [2]

E = power consumption [3]

F = voltage group [4]

G = internal code

H = packaging type [5]

IJ = internal code

V = forward voltage bin

1234 = color bin or CCT bin

Note:

1. Table of radiation patterns

Symbol	Description
1	Lambertian
2	Others

2. Table of color offerings:

Symbol	Color	Color Temperature
C	Cool-White	4745~7050K
N	Neutral-White	3710~4745K
M	Warm-White	2580~3710K

3. Table of power consumptions:

Symbol	Description
1	1W
2	2W
4	4W

4. Voltage group.

Voltage group	Description
0	$0 < V_F < 25$
1	$25 < V_F < 75$
2	$75 < V_F < 127$
3	$127 < V_F < 175$
4	$175 < V_F < 243$

5. Table of packaging types:

Symbol	Description
P	Tape
B	Tube
T	Tray

Absolute Maximum Ratings (Ts=25°C)

Parameter	Symbol	Ratings	Unit
Max. DC Forward Current (mA)	I _F	30 _[1]	mA
Max. ESD Resistance	V _B	2000	V
Reverse Voltage	V _R	Note _[2]	V
Thermal Resistance	R _{th}	10~12	°C/W
Max. Junction Temperature	T _J	125	°C
Operating Temperature	T _{Op}	-40 ~ +100 _[3]	°C
Storage Temperature	T _{Stg}	-40 ~ +100	°C
Max. Soldering Temperature	T _{Sol}	260	°C
Allowable Reflow Cycles	n/a	2 _[4]	cycles

Notes:

1. Maximum forward current for 1W is 30mA (Thermal Pad=25°C).
2. The HV series LEDs are not designed for reverse bias operation.
3. Avoid operating HV LEDs at maximum operating temperature exceeding 1 hour.
4. It is not recommended to subject LED to two cycles of reflow.

JEDEC Moisture Sensitivity

Level	Floor Life		Soak Requirements Standard	
	Time (hours)	Conditions	Time (hours)	Conditions
1	unlimited	≤ 30°C / 85% RH	168 (+5/-0)	85°C / 85% RH

Luminous Flux Characteristics for the EZHV 1W series

Color	Part Number	1W		
		Minimum Luminous Flux(lm)	Drive Current (mA)	View Angle Type (°)
Warm White 3000	EZHV – F61M1	60	20	110
Cool White 5700	EZHV – F81C1	80		
Cool White 6500	EZHV – F81C1	80		

Notes:

1. Luminous flux measurement tolerance: $\pm 10\%$.
2. The data of luminous flux measured at thermal pad=25°C
3. Typical luminous flux or light output performance is operated within the condition guided by this datasheet

PN of the EZHV 1W series : White LEDs

The table below is a list of part numbers for the Everlight EZHV 1W series HV LED. All parts listed match ANSI binning standards. Bin offerings of 3000K ,5700K and 6500K are listed and currently available. Typical view angle is 110°. These clearly listed binning options allow for proper design and implementation into lighting applications. The Order Codes below are currently available EZHV 1W LEDs.

For Example: If you order product using P/N **EZHV-F61M1-1LPHS-F3000**, you will be specifying:

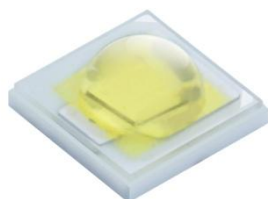

Color Variant	Radiation Pattern	CRI	CCT	Forward Voltage (V)	Minimum Luminous Flux (lm)
Warm White	Lambertian	80	30K-1 ~ 30K-2 ~ 30K-3 ~ 30K-4	47-49(A3) 49-51(A4) 51-53(A5) 53-55(A6)	60

EZHV 1W series LEDs at 20mA are listed below :

Color	Order Code of EZHV	Minimum Luminous Flux (lm)		CCT (K) Wavelength (nm)	CRI (min)	Forward Voltage (V)
		F6	60			
Warm White 3000	EZHV-F61M1-1LPHS-F3000	F6	60	30K-1~30K-4	80	
		F7	70			
		F8	80			
Cool White 5700	EZHV-F81C1-1LPGS-F5700	F8	80	57K-1~57K-4	70	47~55
		F9	90			
		J1	100			
Cool White 6500	EZHV-F81C1-1LPGS-F6500	F8	80	65K-1~65K-4	70	
		F9	90			
		J1	100			

Notes:

1. CRI measurement tolerance: ± 2 .
2. Luminous flux measurement tolerance: $\pm 10\%$.
3. The data of luminous flux is measured at thermal pad=25°C

Product Binning

Luminous Flux Bins

Group	Bin	Minimum Photometric Flux (lm)	Maximum Photometric Flux (lm)
E	1	4	5
	2	5	6
	3	6	8
	4	8	10
	5	10	13
	6	13	17
	7	17	20
	8	20	23
	9	23	27
F	1	27	33
	2	33	39
	3	39	45
	4	45	52
	5	52	60
	6	60	70
	7	70	80
	8	80	90
	9	90	100
J	1	100	110
	2	110	120
	3	120	130
	4	130	140
	5	140	150
	6	150	160
	7	160	180
	8	180	200
	9	200	225

Group	Bin	Minimum Photometric Flux (lm)	Maximum Photometric Flux (lm)
K	1	225	250
	2	250	275
	3	275	300
	4	300	325
	5	325	350
	6	350	375
	7	375	400
	8	400	425
	9	425	450
N	1	450	475
	2	475	500
	3	500	525
	4	525	550
	5	550	575
	6	575	600
	7	600	625
	8	625	650
	9	650	675
P	1	675	700
	2	700	725
	3	725	750
	4	750	775
	5	775	800
	6	800	850
	7	850	900
	8	900	950
	9	950	1000

Notes:

1. Currently available brightness bins available for White LEDs are highlighted and bolded.

White Bin Coordinates

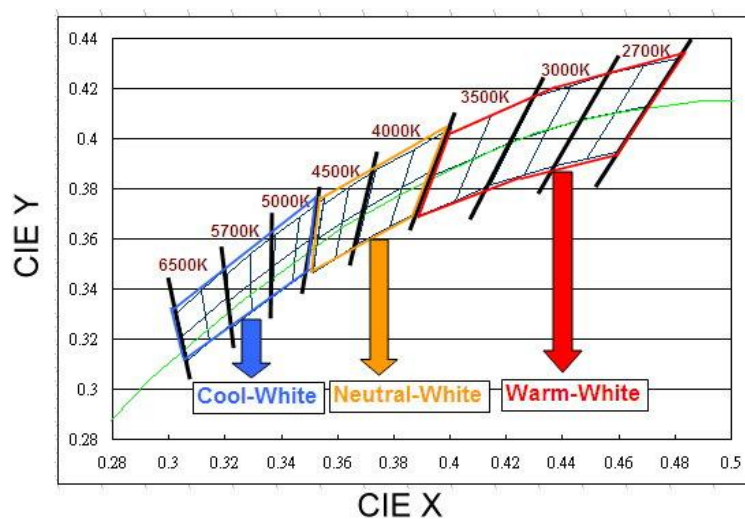

Chromaticity specification defined by ANSI

Notes:

1. The CCT range of Cool-White varies from 4745K to 7050K.
2. The CCT range of Neutral-White varies from 3710K to 4745K.
3. The CCT range of Warm-White varies from 2580K to 3710K.
4. Color coordinates measurement allowance: ± 0.01 .
5. Color bins are defined as $I_f=20\text{mA}$ operation within EZHV 1W series.

Cool-White Bin Structure

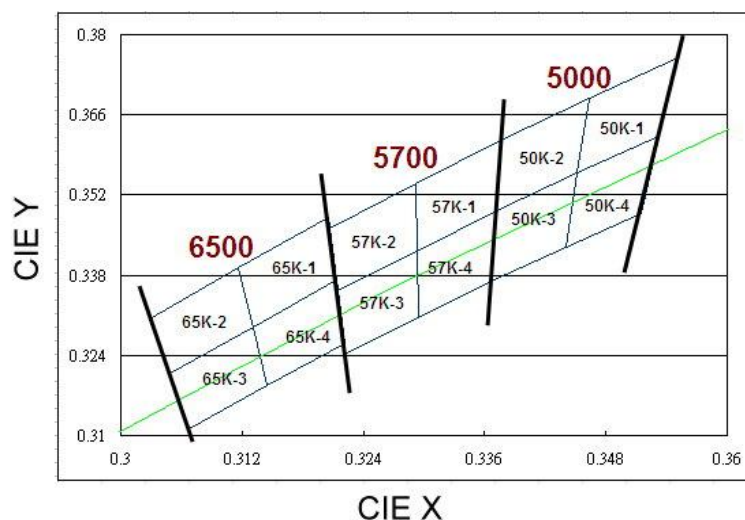

Cool-White Bin Coordinates

6500K

Bin	CIE X	CIE Y
65K-1	0.312	0.339
	0.313	0.329
	0.321	0.337
	0.321	0.348
Reference Range: 6020~6500K		

Bin	CIE X	CIE Y
65K-4	0.313	0.329
	0.315	0.319
	0.322	0.326
	0.321	0.337
Reference Range: 6020~6500K		

5700K

Bin	CIE X	CIE Y
57K-1	0.329	0.354
	0.329	0.342
	0.337	0.349
	0.338	0.362
Reference Range: 5310~5700K		

Bin	CIE X	CIE Y
57K-4	0.329	0.342
	0.329	0.331
	0.337	0.337
	0.337	0.349
Reference Range: 5310~5700K		

Bin	CIE X	CIE Y
65K-2	0.303	0.330
	0.305	0.321
	0.313	0.329
	0.312	0.339
Reference Range: 6500~7050K		

Bin	CIE X	CIE Y
65K-3	0.305	0.321
	0.307	0.311
	0.315	0.319
	0.313	0.329
Reference Range: 6500~7050K		

Bin	CIE X	CIE Y
57K-2	0.321	0.346
	0.321	0.335
	0.329	0.342
	0.329	0.354
Reference Range: 5700~6020K		

Bin	CIE X	CIE Y
57K-3	0.321	0.335
	0.322	0.324
	0.329	0.331
	0.329	0.342
Reference Range: 5700~6020K		

5000K

Bin	CIE X	CIE Y
50K-1	0.346	0.369
	0.345	0.356
	0.353	0.362
	0.355	0.376
Reference Range: 4745~5000K		

Bin	CIE X	CIE Y
50K-4	0.345	0.356
	0.344	0.343
	0.352	0.349
	0.353	0.362
Reference Range: 4745~5000K		

Bin	CIE X	CIE Y
50K-2	0.338	0.362
	0.337	0.349
	0.345	0.356
	0.346	0.369
Reference Range: 5700~6020K		

Bin	CIE X	CIE Y
50K-3	0.337	0.349
	0.337	0.337
	0.344	0.343
	0.345	0.356
Reference Range: 5700~6020K		

Neutral-White Bin Structure

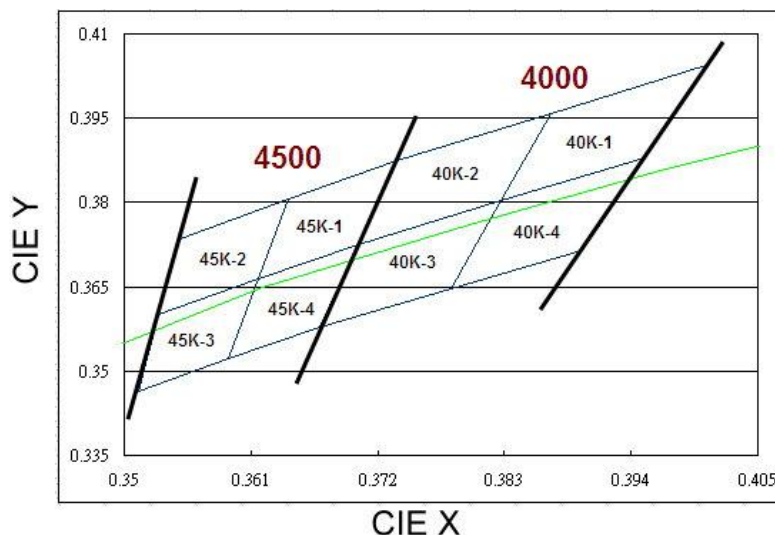

Neutral-White Bin Coordinates

4500K

Bin	CIE X	CIE Y
45K-1	0.364	0.381
	0.362	0.366
	0.370	0.373
	0.374	0.387
Reference Range: 4260~4500K		

Bin	CIE X	CIE Y
45K-2	0.355	0.374
	0.353	0.360
	0.362	0.366
	0.364	0.381
Reference Range: 4500~4745K		

Bin	CIE X	CIE Y
45K-4	0.362	0.366
	0.359	0.352
	0.367	0.358
	0.370	0.373
Reference Range: 4260~4500K		

Bin	CIE X	CIE Y
45K-3	0.353	0.360
	0.351	0.347
	0.359	0.352
	0.362	0.366
Reference Range: 4500~4745K		

4000K

Bin	CIE X	CIE Y
40K-1	0.387	0.396
	0.383	0.380
	0.395	0.388
	0.401	0.404
Reference Range: 3710~4000K		

Bin	CIE X	CIE Y
40K-2	0.374	0.387
	0.370	0.373
	0.383	0.380
	0.387	0.396
Reference Range: 4000~4260K		

Bin	CIE X	CIE Y
40K-4	0.383	0.380
	0.378	0.365
	0.390	0.372
	0.395	0.388
Reference Range: 3710~4000K		

Bin	CIE X	CIE Y
40K-3	0.370	0.373
	0.367	0.358
	0.378	0.365
	0.383	0.380
Reference Range: 4000~4260K		

Warm-White Bin Structure

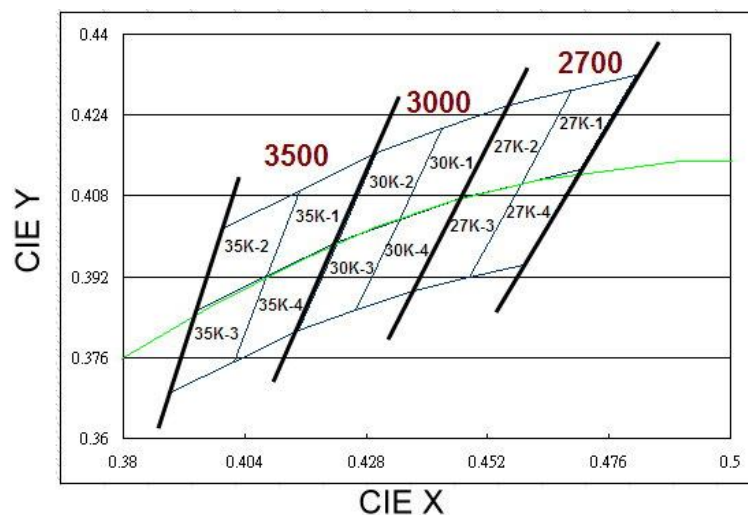

Warm-White Bin Coordinates

3500K

Bin	CIE X	CIE Y
35K-1	0.415	0.409
	0.408	0.392
	0.422	0.399
	0.430	0.417
Reference Range: 3220~3500K		

Bin	CIE X	CIE Y
35K-2	0.400	0.402
	0.394	0.385
	0.408	0.392
	0.415	0.409
Reference Range: 3500~3710K		

Bin	CIE X	CIE Y
35K-4	0.408	0.392
	0.402	0.375
	0.415	0.381
	0.422	0.399
Reference Range: 3220~3500K		

Bin	CIE X	CIE Y
35K-3	0.394	0.385
	0.389	0.369
	0.402	0.375
	0.408	0.392
Reference Range: 3500~3710K		

3000K

Bin	CIE X	CIE Y
30K-1	0.443	0.421
	0.435	0.403
	0.447	0.408
	0.456	0.426
Reference Range: 2870~3000K		

Bin	CIE X	CIE Y
30K-2	0.430	0.417
	0.422	0.399
	0.435	0.403
	0.443	0.421
Reference Range: 3000~3220K		

Bin	CIE X	CIE Y
30K-4	0.435	0.403
	0.426	0.385
	0.437	0.389
	0.447	0.408
Reference Range: 2870~3000K		

Bin	CIE X	CIE Y
30K-3	0.422	0.399
	0.415	0.381
	0.426	0.385
	0.435	0.403
Reference Range: 3000~3220K		

2700K

Bin	CIE X	CIE Y
27K-1	0.469	0.429
	0.459	0.410
	0.470	0.413
	0.481	0.432
Reference Range: 2580~2700K		

Bin	CIE X	CIE Y
27K-4	0.459	0.410
	0.448	0.392
	0.459	0.394
	0.470	0.413
Reference Range: 2580~2700K		

Bin	CIE X	CIE Y
27K-2	0.456	0.426
	0.447	0.408
	0.459	0.410
	0.469	0.429
Reference Range: 2700~2870K		

Bin	CIE X	CIE Y
27K-3	0.447	0.408
	0.437	0.389
	0.448	0.392
	0.459	0.410
Reference Range: 2700~2870K		

Forward Voltage Bins

Group Name	Bins
A	A3+A4
B	A4+A5
C	A5+A6
D	A3+A4+A5
E	A4+A5+A6
F	A3+A4+A5+A6

Bins	Production Line	
	Minimum voltage (V)	Maximum voltage (V)
A1	43	45
A2	45	47
A3	47	49
A4	49	51
A5	51	53
A6	53	55
A7	55	57
A8	57	59
A9	59	61

Notes:

1. Forward voltage measurement tolerance: $\pm 1V$.
2. Forward voltage bins are defined at $I_f=20mA$ operation.
3. Other Forward Voltage bins for White LEDs available upon request. Please contact your local Everlight sales office.

Mechanical Dimension

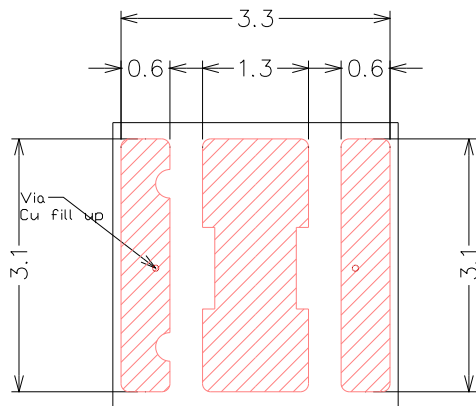
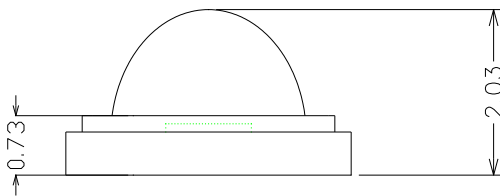
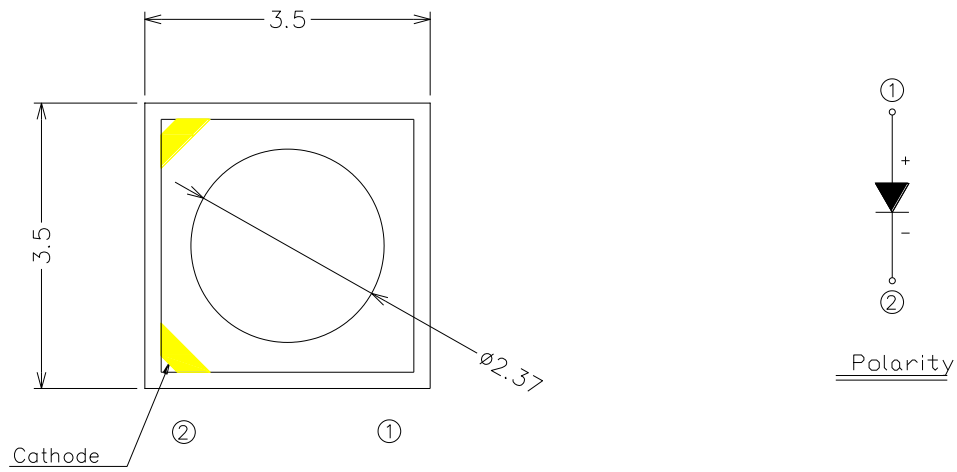

Solder pad design

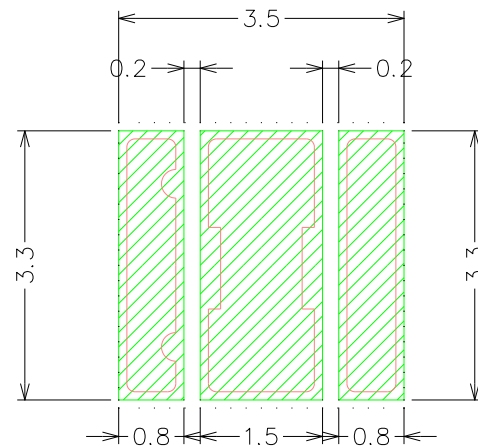

Soldering patterns

Notes:

1. Dimensions are in millimeters.
2. Tolerances unless mentioned are $\pm 0.15\text{mm}$.
3. Do not handle the device by the lens. Incorrect force applied to the lens may lead to the failure of devices.
4. The thermal pad is electrically isolated from the Anode and Cathode contact pads.

Pad Configuration

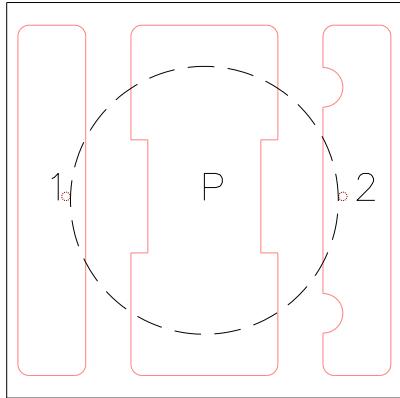

BOTTOM VIEW

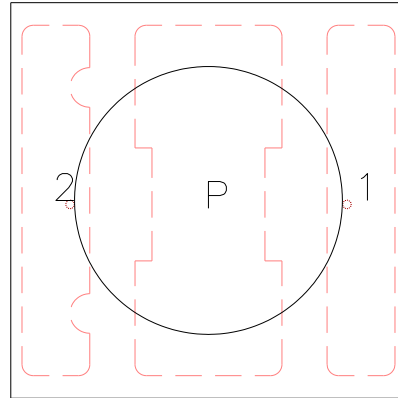

TOP VIEW

PAD	FUNCTION
1	ANODE
2	CATHODE
P	THERMAL PAD

Reflow Soldering Characteristics

For Reflow Process

- A. Suitable for SMT processes.
- B. Curing of glue in oven must be according to standard operation flow processes.

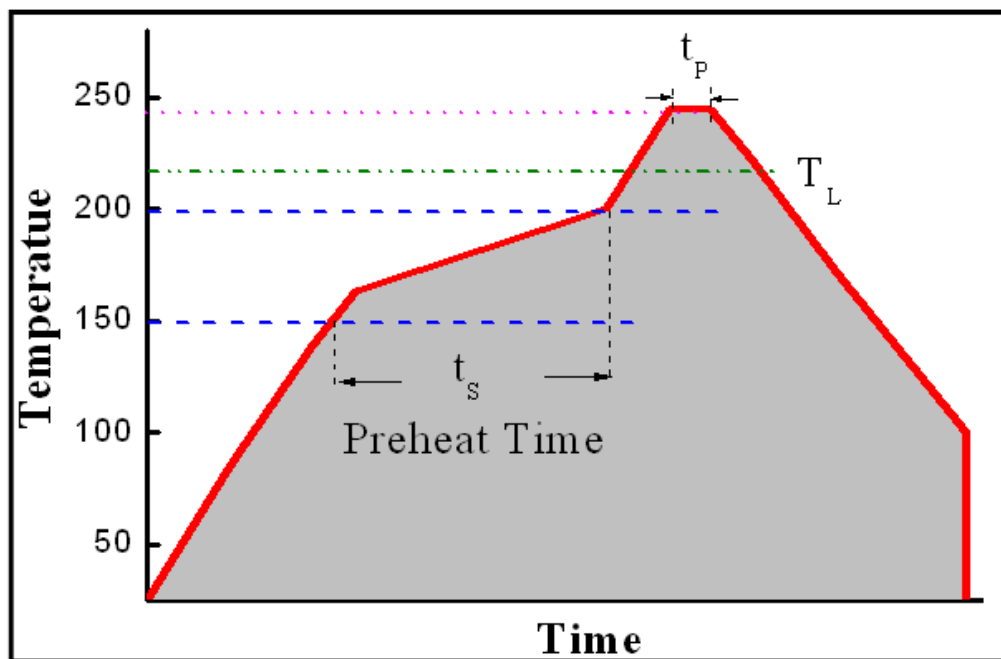

Profile Feature	Lead Free Assembly
Ramp-Up Rate	2-3 °C/S
Preheat Temperature	150-200 °C
Preheat Time (t_s)	60-120 S
Liquid Temperature (T_L)	217 °C
Time maintained above T_L	60-90 S
Peak Temperature (T_P)	240±5 °C
Peak Time (t_p)	Max 20 S
Ramp-Down Rate	3-5 °C/S

- C. Reflow soldering should not be done more than twice.
- D. In soldering process, stress on the LEDs during heating should be avoided.
- E. After soldering, do not bend the circuit board.

Typical Wavelength Characteristics

For Cool-White (Thermal Pad Temperature = 25°C)

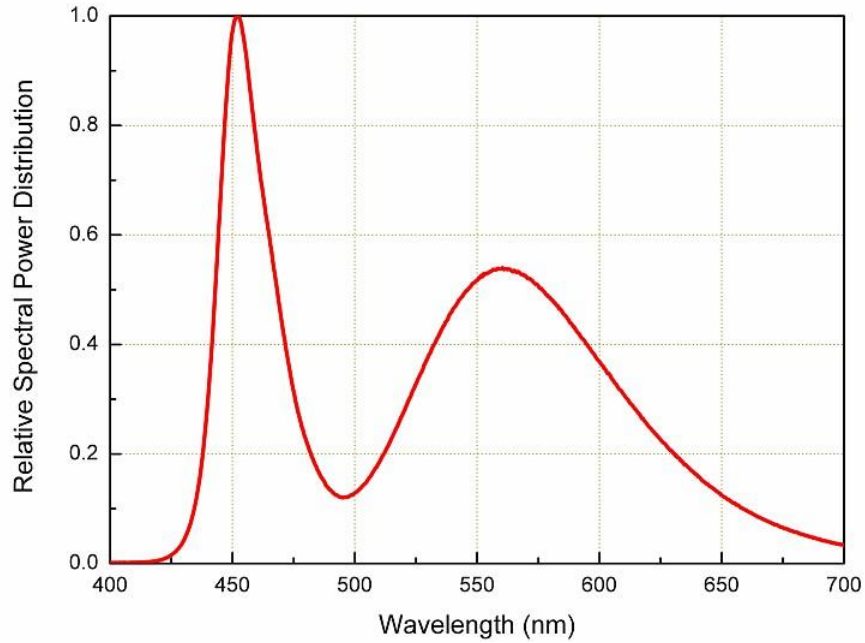

For Warm-White (Thermal Pad Temperature = 25°C)

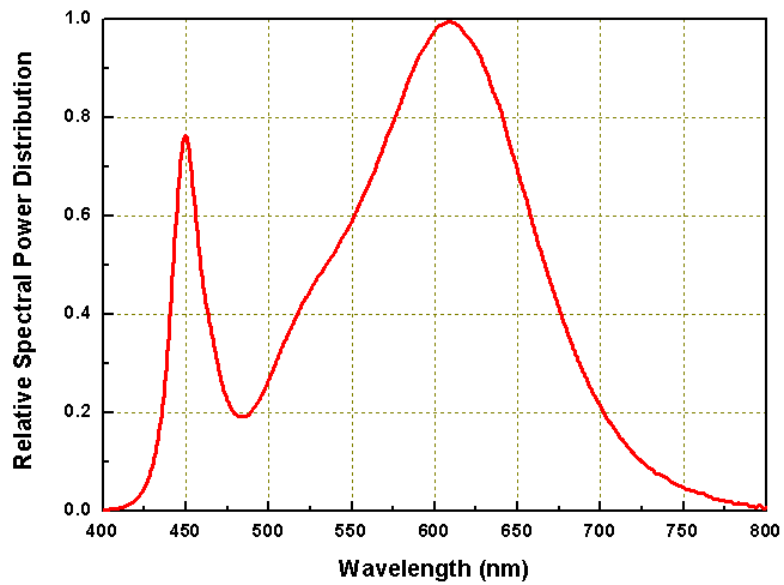

Typical Light Output Characteristic vs. Thermal Pad Temperature

Cool-White and Warm-White for 20mA Drive Current

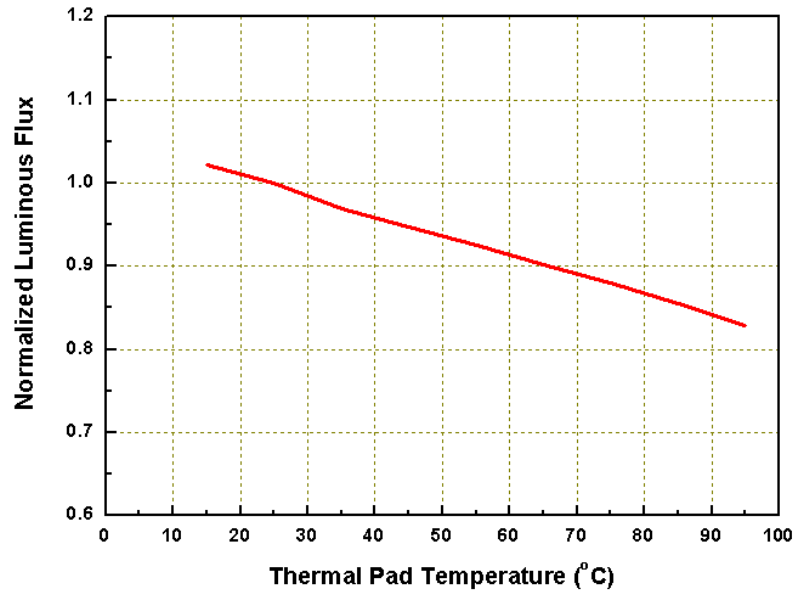

Typical Relative Luminous Flux vs. Forward Current

Cool-White and Warm-White for 20mA Drive Current
@ Thermal Pad Temperature = 25°C

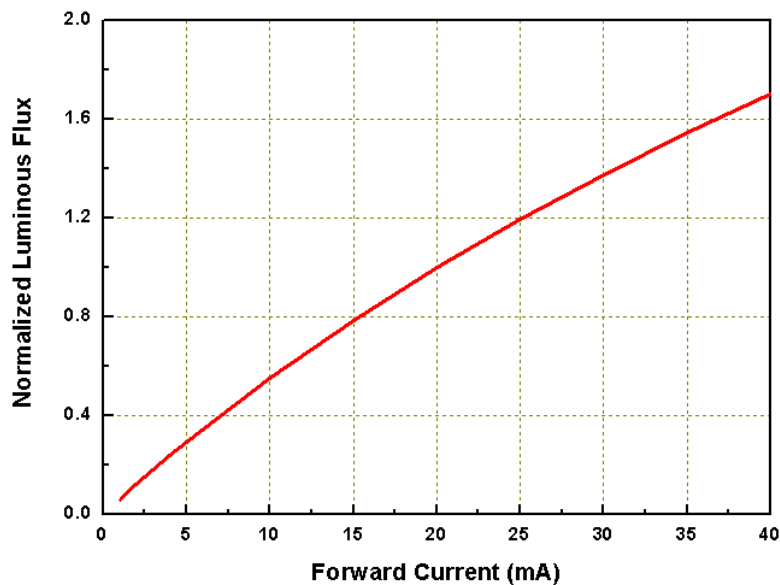

Typical Electrical Characteristics

Cool-White and Warm-White for 20mA Drive Current
@ Thermal Pad Temperature = 25°C

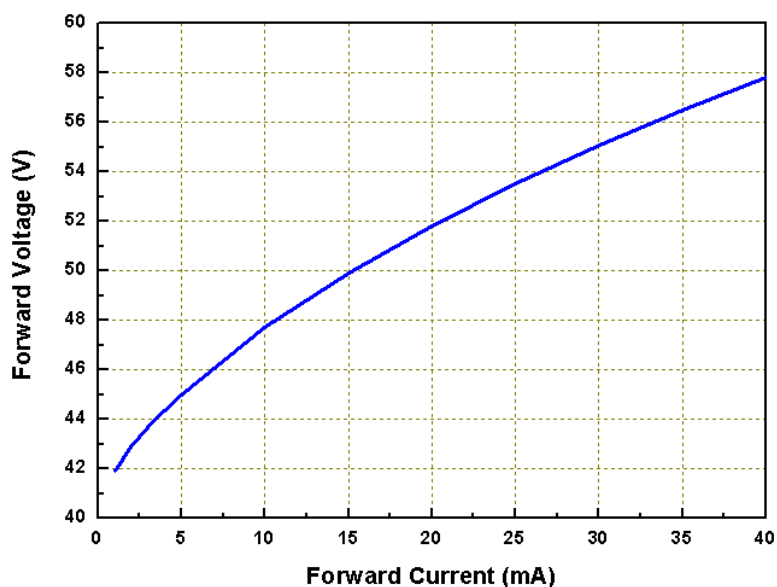

Typical CCT Shift Characteristics vs. Forward Current

For Cool-White @ Thermal Pad Temperature = 25°C

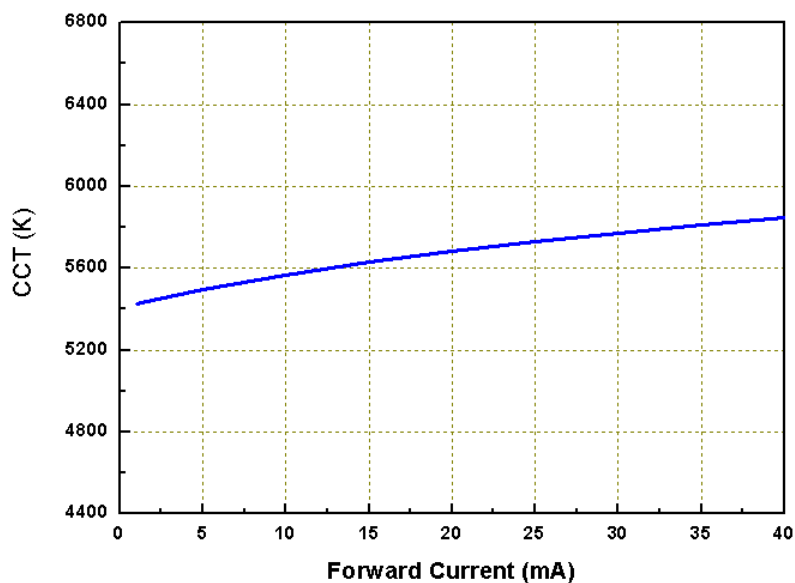

For Warm-White @ Thermal Pad Temperature = 25°C

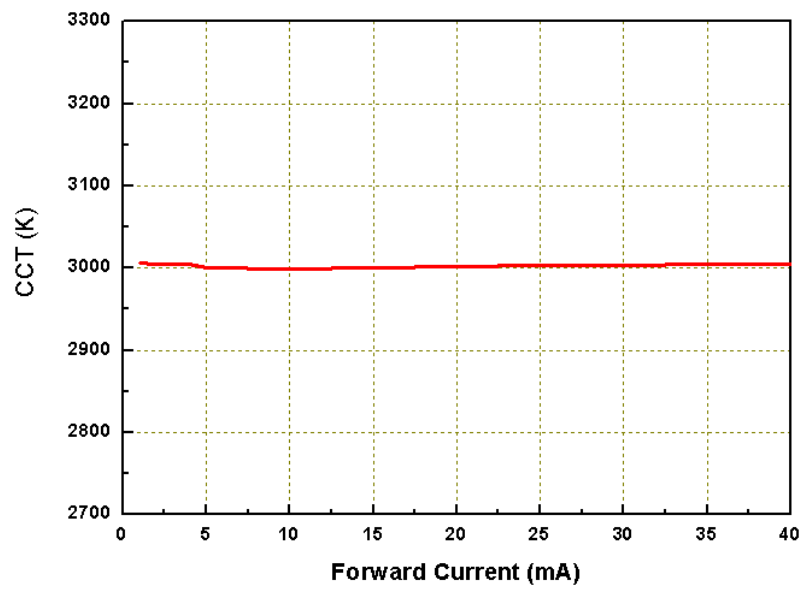

Typical Radiation Patterns

Typical Spatial Radiation Pattern for Cool-White and Warm-White

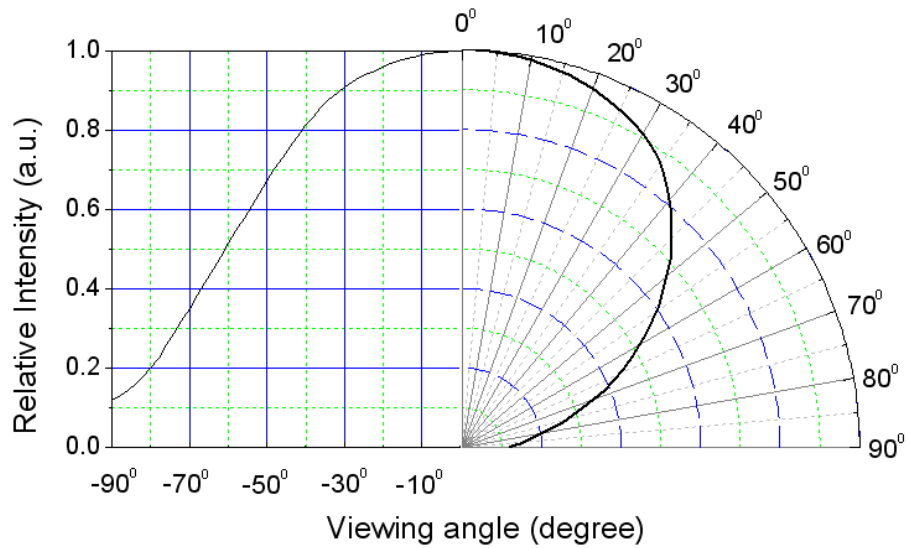

Notes:

1. $2\theta_{1/2}$ is the off axis angle from lamp centerline where the luminous intensity is 1/2 of the peak value.
2. Viewing angle tolerance is $\pm 10^\circ$.

Typical Difference of CIE of Cool-White vs. Angle

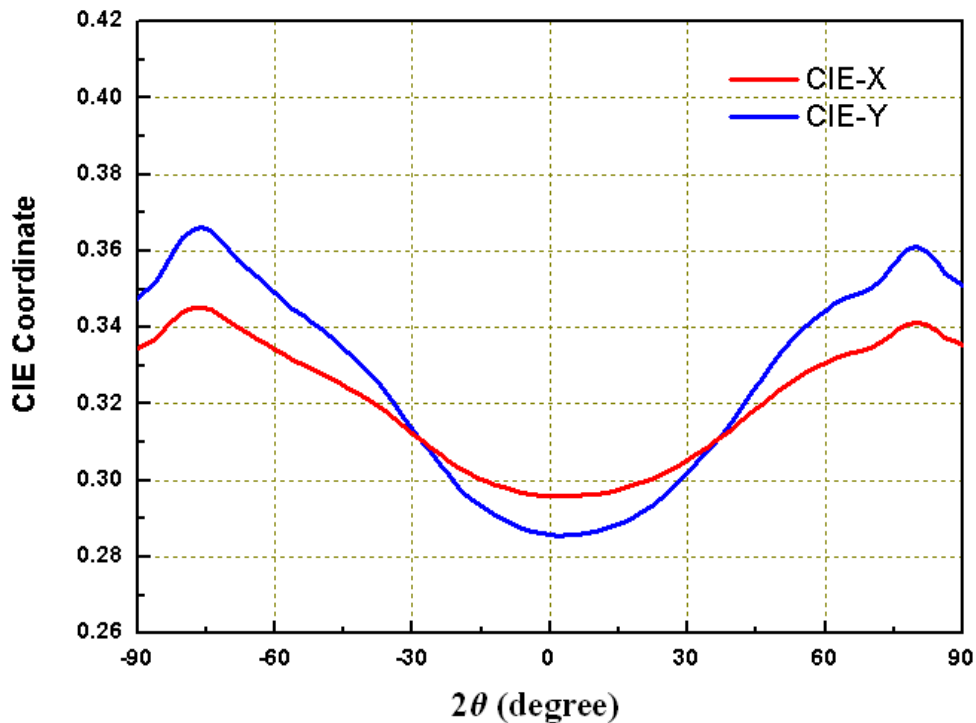

Typical Difference of CIE of Warm-White vs. Angle

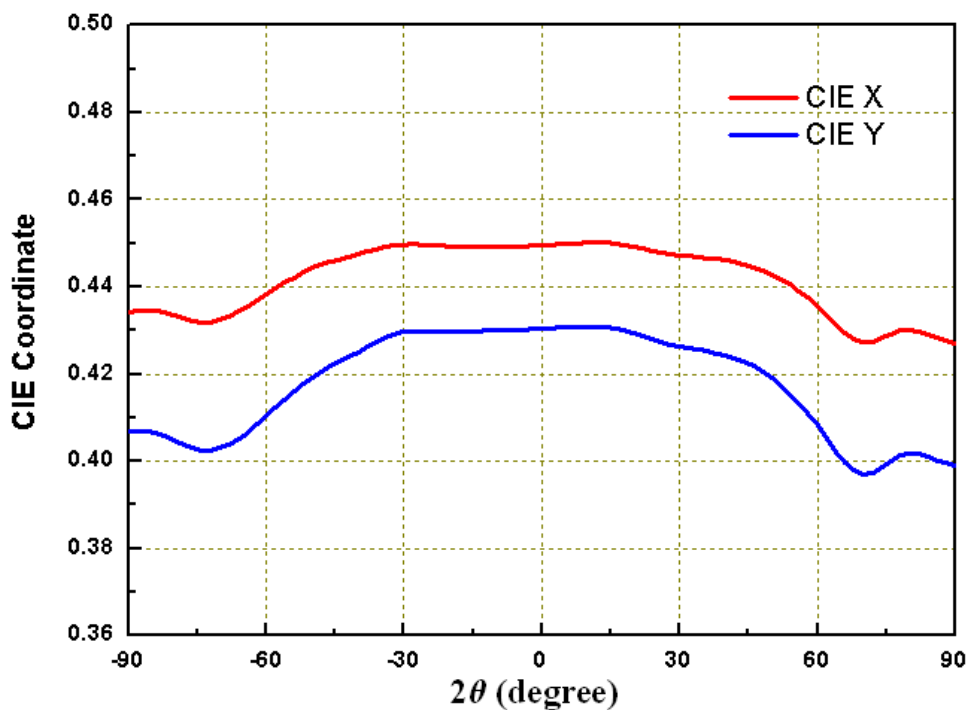

Storage Conditions

- Before the package is opened. The LEDs should be stored at 30°C or less and 85%RH or less after being shipped from Everlight and the storage life limits are 1 year. If the LEDs are stored for 1 year or more, they can be stored for 3 years in a sealed container with a nitrogen atmosphere and moisture absorbent material.
- After opening the package: The LED's floor life is 1 year under 30°C or less and 60%RH or less. The LED should be soldered with 168hrs (7days) after opening the package. If unused LEDs remain, it should be stored in moisture proof packages.
- If the moisture absorbent material (silica gel) has faded away or the LEDs have exceeded the storage time, baking treatment should be performed using the following conditions. Baking treatment: 60±5°C for 24 hours.

Revision History

Current version: 10/19/2011

Previous version: 05/10/2011

Device No.

Rev.3

Page	Subjects (major change in previous version)	Date of change
	New Spec.	05/10/2011
5 , 6 , 9	Increased Bin offerings of 2700K,3500K,4000K,4500K,5000K, 5700K,6500K	09/22/2011
21	modified Emitter Tape Packaging	09/22/2011
9	Modified 65K-4 & 65K-3 CIE-X is 0314 changed of 0.315	10/19/2011
15	Modified Mechanical Dimension of the tolerances unless mentioned are $\pm 0.15\text{mm}$	10/19/2011
24	Modified of Emitter Tape Packaging	10/19/2011