

Digital Output Board with Relay-Isolation
for PCI Express

RRY-32-PE



* Specifications, color and design of the products are subject to change without notice.

Features

32 read relay contact outputs (with a single make contact)

This product has 32 reed relay outputs with a single make contact. 1 common terminal provided per 8 channels. High-capacity output ratings are designed for a maximum of 0.5A 100VDC per channel, a maximum of 1A in total 8 channels (per 1 common). Relay contactor rating is 10W maximum.

Functions and connectors are compatible with PCI compatible board RRY-32(PCI)H.

The functions same with PCI compatible board RRY-32(PCI)H are provided. In addition, there is compatibility in terms of connector shape and pin assignments. For the spec. of relay contact, DC (Direct current) is same with the RRY-32(PCI)H.

Windows/Linux compatible driver libraries are attached

Using the attached driver library API-PAC(W32) makes it possible to create applications of Window/Linux. In addition, a diagnostic program by which the operations of hardware can be checked is provided.

LabVIEW is supported by a plug-in of dedicated library VI-DAQ.

Using the dedicated library VI-DAQ makes it possible to make a LabVIEW application.

This product is PCI Express bus-compliant interface board that output signals to lead relay contacts.

The RRY-32-PE provides up to 32 lead relay contact outputs. 1 common terminal provided per 8 channels. High-capacity output ratings are designed for a maximum of 0.5A 100VDC per channel, a maximum of 1A in total 8 channels (per 1 common). Relay contactor rating is 10W maximum. Windows/Linux driver is bundled with this product. Possible to be used as a data recording device for LabVIEW, with dedicated libraries.

Specification

Items	Specifications	
No. of Output Channels	32 channels (1 common in total eight channels *1)	
Output Format	Reed Relay (1a, make) Output	
Relay Contact Spec.	Max. permitted power	10W(DC)
	Max. permitted voltage	100V(DC)
	Max. Carry Current	0.5A(Max.)
	Contact resistance	150mΩ or less
	Response Time	Within 1ms
	Mechanical Life Expectancy	200,000,000 operations min or more
	Relay Type	RG1003W6
I/O Address	8 bits x 32 ports boundary	
Max. board count in One System	16 boards including this board	
Power Consumption	3.3VDC 900mA (Max.)	
Operating Condition	0 - 50°C, 10 - 90%RH (No condensation)	
Bus Specification	PCI Express Base Specification Rev. 1.0a x1	
Dimension(mm)	169.33(L) x 110.18(H)	
Connector used	37-pin D-SUB, female connector DCLC-J37SAF-20L9E(mfd. by JAE) or equivalent to it	
Weight	120g	
Certification	RoHS,CE,VCCI	

*1 In total of 8 channels (per common), do not exceed the maximum of 1A. Doing so may cause malfunction.

Board Dimensions

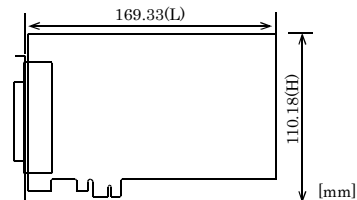

The standard outside dimension (L) is the distance from the end of the board to the outer surface of the slot cover.

Support Software

Windows version of digital I/O driver API-DIO(WDM) / API-DIO(98/PC)

[Stored on the bundled Disk driver library API-PAC(W32)]

The API-DIO(WDM) / API-DIO(98/PC) is the Windows version driver library software that provides products in the form of Win32 API functions (DLL). Various sample programs such as Visual Basic and Visual C++, etc and diagnostic program useful for checking operation is provided.

You can download the updated version from the CONTEC's Web site (<http://www.contec.com/apipac/>). For more details on the supported OS, applicable language and new information, please visit the CONTEC's Web site.

Linux version of digital I/O driver API-DIO(LNX)

[Stored on the bundled Disk driver library API-PAC(W32)]

The API-DIO(LNX) is the Linux version driver software which provides device drivers (modules) by shared library and kernel version. Various sample programs of gcc are provided.

You can download the updated version from the CONTEC's Web site (<http://www.contec.com/apipac/>). For more details on the supported OS, applicable language and new information, please visit the CONTEC's Web site.

Data acquisition VI library for LabVIEW VI-DAQ (Available for downloading (free of charge) from the CONTEC web site.)

This is a VI library to use in National Instruments LabVIEW. VI-DAQ is created with a function form similar to that of LabVIEW's Data Acquisition VI, allowing you to use various devices without complicated settings.

See <http://www.contec.com/vidaq/> for details and download of VI-DAQ.

Cable & Connector

Cable (Option)

Flat cable with both-ends 37-pin D-SUB connector
 : PCB37P-1.5 (1.5m)
 : PCB37P-3 (3m)
 : PCB37P-5 (5m)

Shield cable with both-ends 37-pin D-SUB connector
 : PCB37PS-0.5P (0.5m)
 : PCB37PS-1.5P (1.5m)
 : PCB37PS-3P (3m)
 : PCB37PS-5P (5m)

Flat cable with one-end 37-Pin D-SUB connector
 : PCA37P-1.5 (1.5m)
 : PCA37P-3 (3m)
 : PCA37P-5 (5m)

Shield cable with one-end 37-pin D-SUB connector
 : PCA37PS-0.5P (0.5m)
 : PCA37PS-1.5P (1.5m)
 : PCA37PS-3P (3m)
 : PCA37PS-5P (5m)

Connector (Option)

37pin D-SUB (male) connector Five-piece set
 : CN5-D37M

⚠ CAUTION

The maximum current rate of each flat cable line (PCB37P-* and PCA37P-*) is 1 A; and the maximum current rate of each shield cable line (PCB37PS-*P and PCA37PS-*P) is 1 A. Should the boards be connected to devices that require larger current value than the above rates, you should prepare connecting cables yourself, instead of ordering our option cables.

Accessories

Accessories (Option)

Screw Terminal (M3 x 37P) : EPD-37A *1*2
 Screw Terminal (M3.5 x 37P) : EPD-37 *1
 General Purpose Terminal(M3 x 37P) : DTP-3A *1
 Screw Terminal (M2.6 x 37P) : DTP-4A *1

*1 A PCB37P or PCB37PS optional cable is required separately.
 *2 "Spring-up" type terminal is used to prevent terminal screws from falling off.
 * Check the CONTEC's Web site for more information on these options.

Packing List

Board [RRY-32-PE] ... 1
 First step guide ... 1
 Disk *1 [API-PAC(W32)] ... 1
 Serial number label... 1
 Product Registration Card & Warranty Certificate... 1

*1 The Disk contains the driver software and User's Guide.

How to connect the connectors

Connector shape

The on-board interface connector (CN1) is used when connecting this product and the external devices.

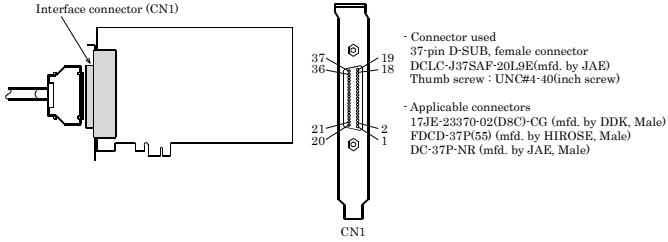

- Connector used
37-pin D-SUB, female connector
DCLC-37S/SAF-20L9E(mfd. by JAE)
Thumb screw : UNC#4-40(inch screw)

- Applicable connectors
17JE-23370-02(D8C)-CG (mfd. by DDK, Male)
FDCD-37P(55) (mfd. by HIROSE, Male)
DC-37P-NR (mfd. by JAE, Male)

* Please refer to page 2 for more information on the supported cable and accessories.

- Connector Pin Assignment

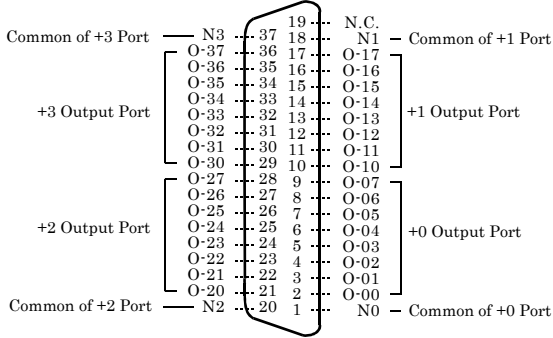

O-00 - O-37	32 output signal pins. Connect these pins to the input signal pins of the external device.
N0 - N3	Common pin corresponding to each output port.
N.C.	No connection to this pin.

Output Signal Connection

Figure below shows the output circuit at the interface section of the board. The signal output section uses a relay contact method to send signals to the external device.

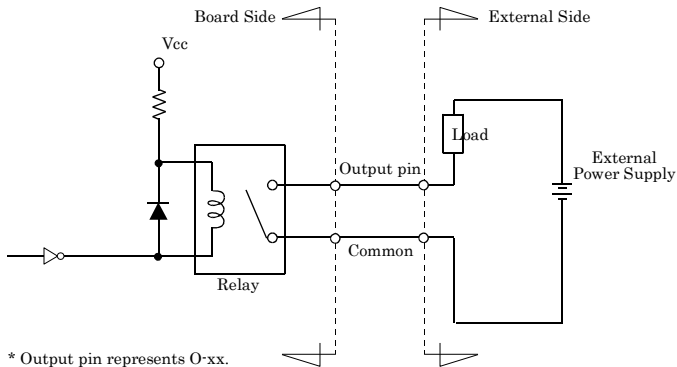

* Output pin represents O-xx.

⚠ CAUTION

When the PC is turned on, all outputs are reset to OFF.

Difference from RRY-32(PCI)H

The spec. of relay contact different from the conventional product of RRY-32(PCI)H is provided with the RRY-32-PE. In addition, there is compatibility in terms of connector shape and pin assignments. There are some differences in specifications as shown below.

	RRY-32(PCI)H	RRY-32-PE
Relay Contact resistance	100Ω or less	150Ω or less
Max. permitted power	10VA(AC), 10W(DC)	10W(DC)
Max. permitted voltage	100V(AC), 100V(DC)	100V(DC)
Relay type	MSG-105AK1	RG1003W6
Power consumption	5VDC 1050mA (Max.)	3.3VDC 900mA (Max.)
Bus specification	32bit, 33MHz, Universal key shapes supported (Supply 5V to the 5V pin)	PCI Express Base Specification Rev. 1.0a x1
Dimension (mm)	176.41(L) x 105.68(H)	169.33(L) x 110.18(H)

⚠ CAUTION

RRY-32-PE is only for DC.

Block Diagram

