

ATLANTIC VERSION TERMINATOR INTERFACE ADAPTER	PART NUMBER	REVISION	DESCRIPTION	FEED TYPE	CONVERT TO	PART NUMBERS REQUIRED					
	2266199-1	A	FINE CRIMP HEIGHT ADJUST	MECHANICAL	PNEUMATIC FEED	2119950-1	1338685-1	5-18022-5	2119641-1	2119799-1	2063440-1
	2266199-2	A	FINE CRIMP HEIGHT ADJUST	PNEUMATIC	SERVO LATCH PLATE	2119951-1	-	8-2266199-5	1901094-3	-	2168400-6 (QUANTITY 2)
					SMART APPLICATOR	2161326-1	-	8-2266199-4	-	-	
					MECHANICAL FEED	2119949-1	1338685-1	5-18022-5	2119653-1	-	-
	2266199-5	A	FINE CRIMP HEIGHT ADJUST	SERVO LATCH PLATE	SERVO LATCH PLATE	2119951-1	-	8-2266199-5	1901094-3	-	2168400-6 (QUANTITY 2)
					SMART APPLICATOR	2161326-1	-	8-2266199-4	-	-	
	2266199-6	A	NON-CRIMP HEIGHT ADJUST	SERVO LATCH PLATE	MECHANICAL FEED	2119949-1	1338685-1	5-18022-5	2119653-1	-	-
PNEUMATIC FEED					2119950-1	1338685-1	5-18022-5	2119641-1	2119799-1	2063440-1	
2266199-7	A	FINE CRIMP HEIGHT ADJUST	NONE	-	-	-	-	-	-	-	
7-2266199-7	A	CRIMP TOOLING KIT	-	-	-	-	-	-	-	-	

APPLICATOR DATA		
CRIMP	SIZE	TYPE
WIRE	2.59 mm [.102]	F
INSUL	3.60 mm [.142]	OV

APPLICATOR INSTRUCTIONS 408-10389

TERMINAL DATA: G&H TERMINAL	G&H CRIMP SPECIFICATION
TERMINAL NAME: AFK FEMALE TERMINAL 2.8 X 0.8	
WIRE STRIP LENGTH 4.70-5.30 mm [.185-.209 IN]	INSULATION DIAMETER RANGE Ø1.90-2.90 mm [.075-.114 IN]
TERMINAL APPLICATION SPECIFICATION G&H Spec Rev 10	
TERMINALS APPLIED	
TE TERMINAL	G&H TERMINAL
1949035-1	26705.201.185
1949035-2	26705.201.702
	1949034-3
	26657.330.185
	26657.201.142
	26657.201.702

WIRE SIZE	CRIMP HEIGHT mm [INCH]	CRIMP HEIGHT REFERENCE SETTING
2.50mm2	1.70+/-0.05 [.067+/-0.002]	5.6
2.25mm2	1.60+/-0.05 [.063+/-0.002]	6.6
1.50mm2	1.45+/-0.05 [.057+/-0.002]	8.1

- 1 RECOMMENDED SPARE PARTS
- 2 GREASE BEARING SURFACES LIGHTLY
- 3 LUBRICATE DAILY PER THE APPLICATOR INSTRUCTION SHEET SUPPLIED WITH THE APPLICATOR.
- 4 APPLICATOR SPECIFIC DATA TO BE ENTERED INTO BLANK MEMORY CHIP AT ASSEMBLY. SEE BELOW FOR PART NUMBER:  
 MECHANICAL FEED WITH "SMART APPLICATOR" CONVERSION: 8-2266199-4  
 PNEUMATIC FEED WITH "SMART APPLICATOR" CONVERSION: 8-2266199-4  
 SERVO FEED WITH "FINE CRIMP HEIGHT ADJUST": 8-2266199-5  
 SERVO FEED WITH "NON-CRIMP HEIGHT ADJUST": 8-2266199-6
- 5 ADJUSTMENT OF THE STRIPPER MAY BE REQUIRED WHEN MOVING THE APPLICATOR BETWEEN BENCH AND LEADMAKER APPLICATIONS.
- 6 APPLY PART NUMBER 1-23419-5 LOCTITE TO THREADS OF ITEMS 62 & 242. FOR -6 ONLY APPLY PART NUMBER 1-23419-5 LOCTITE TO THREADS OF ITEMS 37 & 242.
- 7 GREASE THREADS, GROOVE AND O-RING ON ITEMS 35 & 252.
- 8 MAGNET, ITEM 166 MUST BE ORIENTED CORRECTLY IN ORDER TO PROPERLY ACTUATE THE COUNTER.
- 9 CRIMP HEIGHT REFERENCE SETTING WAS THE SETTING USED WHEN THE APPLICATOR WAS QUALIFIED AT THE FACTORY. ADJUSTMENT MAY BE NECESSARY WHEN RUNNING APPLICATOR IN THE FIELD.
- 10 SPARE FEED CAM STORAGE LOCATION REFER TO INSTRUCTION SHEET FOR ADDITIONAL INFORMATION.
- 11 TO CONVERT THE APPLICATOR TO A NON-CARRIER CUTTING STYLE, REMOVE ITEM 13 AND ATTACH TO THE LOCATION ON THE BACK SIDE OF THE HOUSING. REFER TO INSTRUCTION SHEET FOR ADDITIONAL INFORMATION.
- 12 WHEN ASSEMBLING A NON CRIMP HEIGHT ADJUST APPLICATOR (-6) USE SHIMS FROM ITEM 260 TO ACHIEVE A NOMINAL SHIM HEIGHT OF 4.10.
- 13 THIS APPLICATOR IS SPECIFIC FOR USE IN A STRIPPER SEAL TERMINATING UNIT.
- 14 FOR SINGLE OR DOUBLE WIRE COMBINATIONS.
- 15 FOR MULTIPLE WIRE COMBINATIONS ONLY.

**\*WARNING**  
 ON INSTALLATION, SET WIRE DISC, ITEM 40 TO LARGEST WIRE SIZE SETTING. USE OF SETTINGS BELOW MINIMUM REQUIRED CRIMP HEIGHT SETTING WILL CAUSE DAMAGE TO CRIMP TOOLING.

-77	-7	-6	-5	-2	-1	PART NO	DESCRIPTION	ITEM NO
-	-	1	-	-	-	2119957-2	APPLICATOR SHIM PACK	260
-	1	-	1	1	1	8-21084-0	O-RING, .676 ID, .070 DIA. MAT.	252
-	-	-	-	1	-	2119640-1	PUSH ROD, AIR FEED	250

**ATLANTIC VERSION**  
 Shown on sheets 1 of 4 & 2 of 4  
 (Pacific version shown on sheets 3 of 4 & 4 of 4)

SET UP GAUGE	LOC	DIST	REVISIONS			
2119599-1	A	66	REV	DATE	BY	APPV
			1	DEVELOPMENT	21JAN2014	YY UG
			A	RELEASED	13FEB2014	YY UG

REV	DATE	BY	APPV	DESCRIPTION	ITEM NO	
-	-	-	-	1	2079988-1 BUSHING, LCH5-12, MISUMI	249
-	-	-	-	1	2119641-1 FEED CAM, AIR FEED	248
-	1	-	1	1	2119798-1 DETENT PIN	247
-	1	-	1	1	1-22279-3 SPRING, COMPRESSION	246
-	-	1	-	-	2119758-1 RAM, AMP STYLE, SIDE FEED, NON-ADJ.	245
-	1	1	1	1	2119082-4 CAM, SNAIL, INSULATION ADJUSTMENT	244
-	1	1	1	1	2079764-1 WASHER, WAVE SPRING, CREST-TO-CREST	243
-	1	1	1	1	2119083-1 RETAINER, INSULATION DIAL	242
-	1	1	1	1	7-18023-7 SCR, SKT HD CAP M3 X 4.0	241
-	-	2	2	-	2168400-6 SHCS, LOW HEAD, RoHS, M5 X 16	240
-	-	-	-	1	2119580-1 MECHANICAL FEED ASSEMBLY	239
-	-	-	-	1	2063440-1 AIR FEED MODULE	238
-	-	1	1	-	2119740-2 TAG, IDENTIFICATION	213
-	-	1	1	-	1901094-3 SPACER, FEEDER	198
-	-	-	-	2	21045-3 RING, RETAIN, EXTERN, 3/16 CRESCENT	172
-	1	1	1	1	994969-1 MAGNET, RARE EARTH HIGH ENERGY	166
-	REF	REF	REF	REF	994970-2 COUNTER, MAGNETIC	164
-	-	-	-	1	240638-1 SPRING, FEED FINGER	163
-	-	-	-	1	3-23627-7 PIN, RETAIN, GRVD, 3/16 X .854	137
-	-	-	-	1	2119799-1 HOLDER, FEED FINGER, AF	136
-	-	REF	REF	-	SEE NOTE 4 MEMORY CHIP, PROGRAMMED	135
-	-	1	1	-	1633743-1 SERVO FEED LATCH ASM	133
-	1	1	1	1	1-18028-2 WASHER, FLAT, REG M4	119
-	-	REF	REF	-	2119944-1 FEED FINGER ASSEMBLY, SF	117
-	1	1	1	1	455888-6 SPACER, CRIMPER	82
-	1	1	1	1	2119956-1 DOCUMENTATION PACKAGE	71
-	1	-	-	1	2119740-1 TAG, IDENTIFICATION	67
-	2	2	2	2	2168078-1 SCREW, DRIVE, RH, RoHS, 2 x .188	66
-	1	-	1	1	2119793-1 LIMITER, ADJUSTMENT BOLT	63
-	3	-	3	3	992763-5 SCR, SET, SOC, CONE POINT, M3 X 4.0	62
-	1	1	1	1	2079383-4 SCR, BHSC, RoHS (M4 X 8)	60
-	-	-	-	1	5-18022-5 SCR, HEX HD CAP, M4 X 6.0	59
-	-	-	-	1	1338685-1 PAWL, FEED	56
-	4	4	4	4	2168400-1 SHCS, LOW HEAD, RoHS, M4 X 12	54
-	2	2	2	2	1-2168083-0 SCR, SKT HD CAP, RoHS, M4 X 10	53
-	1	1	1	1	5018030-1 NUT, HEX, REG, RoHS, M3	52
-	1	1	1	1	811242-5 BUMPER, HOLD DOWN	51
-	1	1	1	1	690753-2 SPACER, TONKER	50
-	-	-	-	1	18023-9 SCR, SKT HD CAP M4 X 6.0	49
-	-	-	-	1	2119652-1 FEED CAM, PRE FEED	48
-	-	-	-	1	2119653-1 FEED CAM, POST FEED	47
-	1	1	1	1	2-2119656-1 APPLICATOR BASIC ASSEMBLY, SF	46
-	1	-	1	1	2119370-1 RAM, AMP STYLE, SIDE FEED	44
-	1	1	1	1	2079383-7 SCR, BHSC, RoHS (M8 X 25)	41
-	1	-	1	1	2119645-1 DISC, NUMBERED FA WIRE ADJUSTMENT	40
-	1	-	1	1	2119957-1 APPLICATOR SHIM PACK	39
-	1	1	1	1	1-2119644-2 RAM WASHER, PRECISION	38
-	1	1	1	1	2119085-1 FA HEAD, ATLANTIC STYLE	37
-	1	-	1	1	2119092-1 BOLT, ADJUSTMENT	35
-	1	1	1	1	1-1752356-7 SUPPORT, TERMINAL	34
-	2	2	2	2	2079383-5 SCR, BHSC, RoHS (M4 X 20)	33
-	1	1	1	1	2161328-1 HEX HEAD, FLANGED, M5 X 8mm LONG	32
-	1	1	1	1	1320908-7 SPACER, STRIP GUIDE	30
-	1	1	1	1	2119959-4 ASSEMBLY, STRIP GUIDE	29
-	1	1	1	1	455888-3 SPACER, CRIMPER	28
-	1	1	1	1	240792-1 DRAG, TERMINAL	25
-	1	1	1	1	1320928-2 STRIP GUIDE	24
-	1	1	1	1	2168083-2 SCR, SKT HD CAP, RoHS, M4 X 8.0	21
-	1	1	1	1	1-18028-2 WASHER, FLAT, REG M4	20
-	1	1	1	1	2119533-1 STRIPPER, SIDE FEED	19
-	1	1	1	1	2119806-1 INSERT, SHEAR	13
-	1	1	1	1	3-22280-3 SPRING, COMPRESSION	12
-	1	1	1	1	1-356885-4 STOP, SHEAR	11
-	1	1	1	1	2119805-1 SHEAR HOLDER, FRONT	10
-	1	1	1	1	318707-1 FLOATING SHEAR, FRONT	9
-	1	1	1	1	7-1633927-3 ANVIL, COMBINATION	8
-	-	-	-	-	-	7
-	-	-	-	-	-	6
-	1	1	1	1	2119757-8 DEPRESSOR, SHEAR	5
-	1	1	1	1	2-238011-2 BLOCK, CRIMPER SPACER	4
-	1	1	1	1	1-1633963-6 CRIMPER, INSULATION OVERLAP PREMIUM	3
-	1	1	1	1	455888-1 SPACER, CRIMPER	2
-	1	1	1	1	3-1633305-3 CRIMPER, WIRE PREMIUM	1

DIMENSIONS:		TOLERANCES UNLESS OTHERWISE SPECIFIED:		DATE	REV	DESCRIPTION
mm	0 PLC ±.5	1 PLC ±.5	2 PLC ±.5	21JAN2014	1	INITIALS
	3 PLC ±.5	4 PLC ±.5	5 PLC ±.5	21JAN2014	2	INITIALS
	ANGLES ±.0001					
MATERIAL	FINISH	WEIGHT				

**STE** TE Connectivity  
 Harrisburg, PA 17105-3608

**Ocean Side Feed Applicator**

SIZE: A1 CAGE CODE: 00779 DRAWING NO: 2266199

Customer Accessible Production Drawing SCALE: 1:2 SHEET 1 OF 4 REV: A

LOC		DIST		REVISIONS			
A	66	P	LTM	DESCRIPTION	DATE	DWN	APVD
		-	-	SEE SHEET 1	-	-	-

### FEED TYPE MECHANICAL

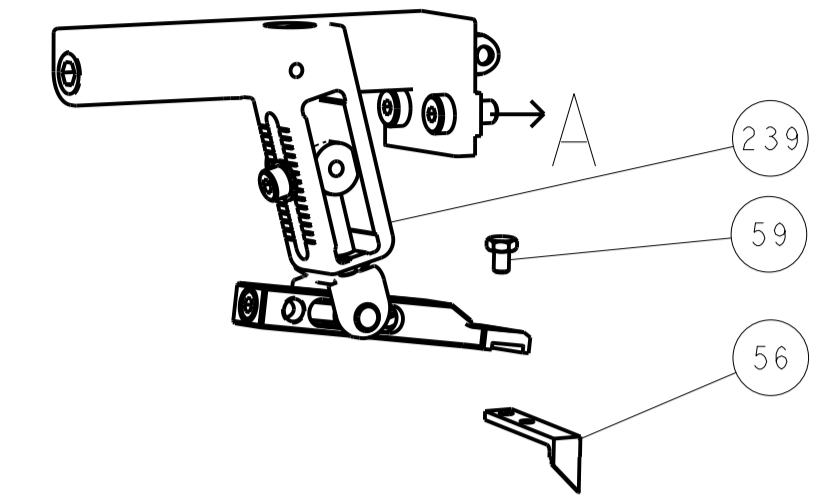

### PNEUMATIC

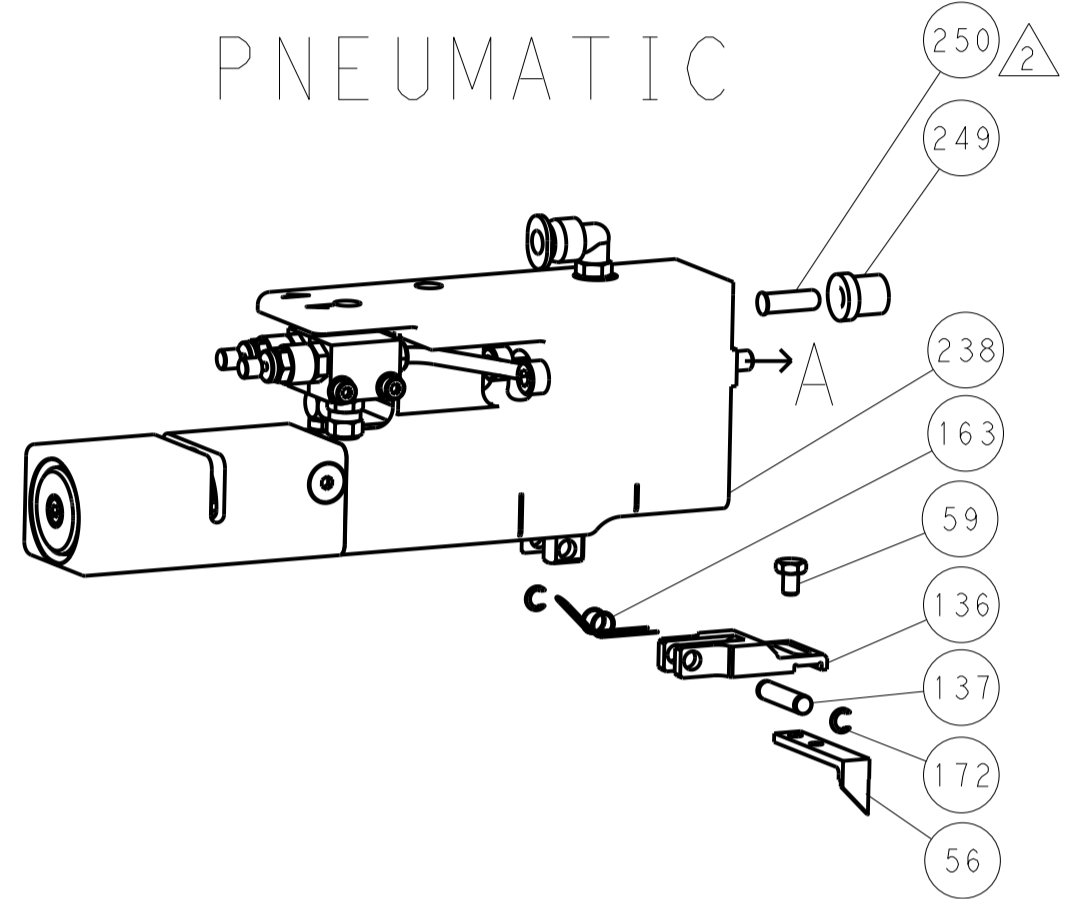

### SERVO LATCH PLATE

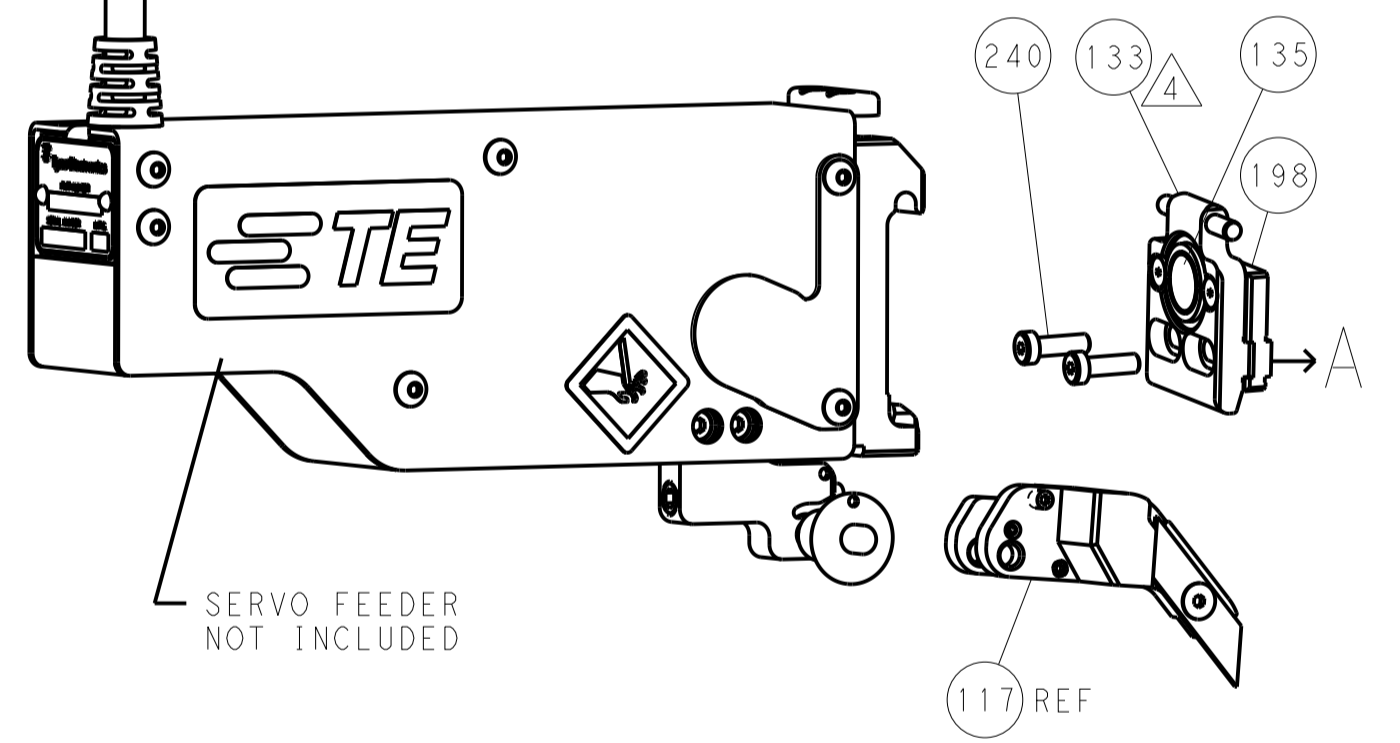

### CAM POSITIONS

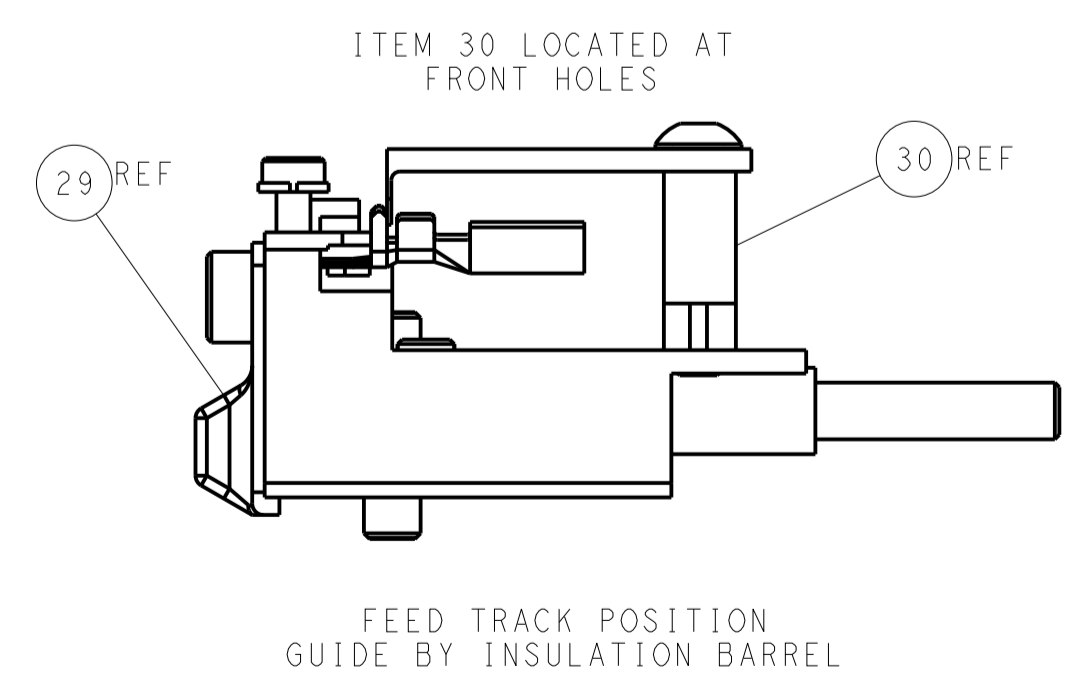
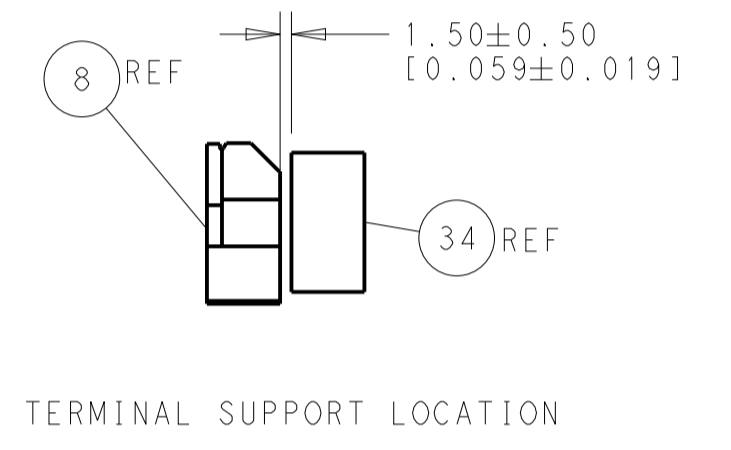
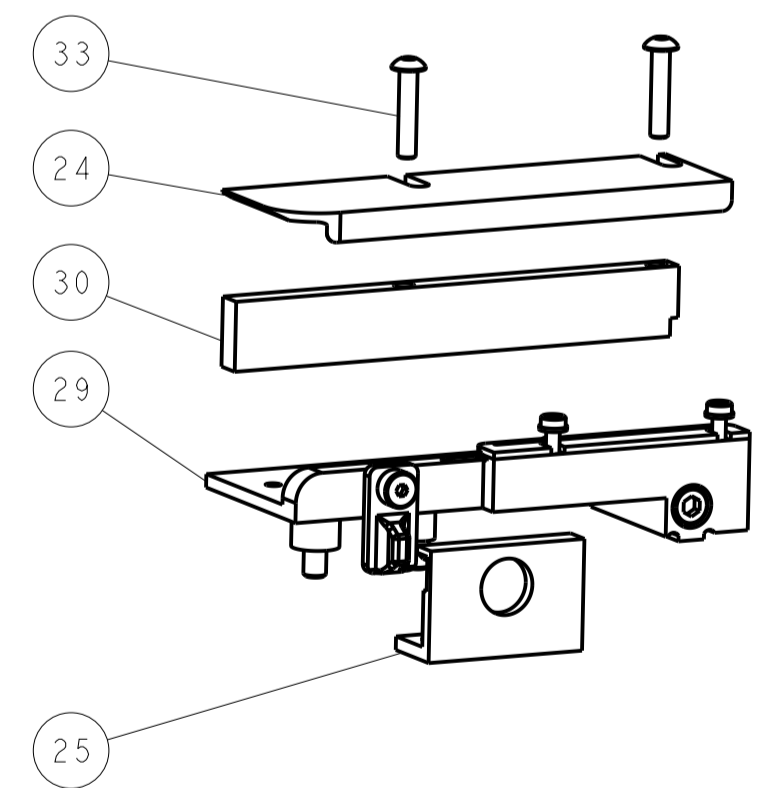
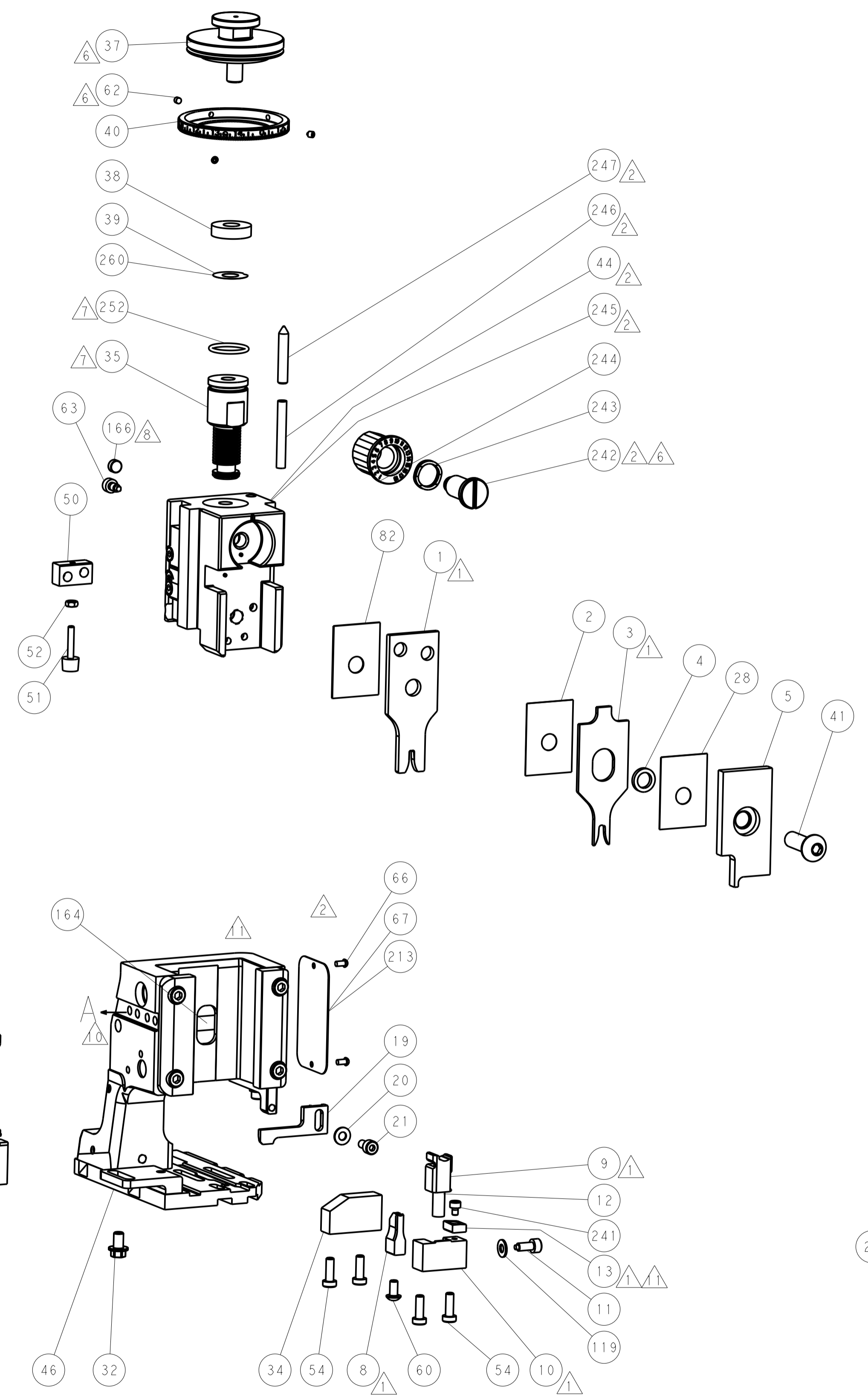
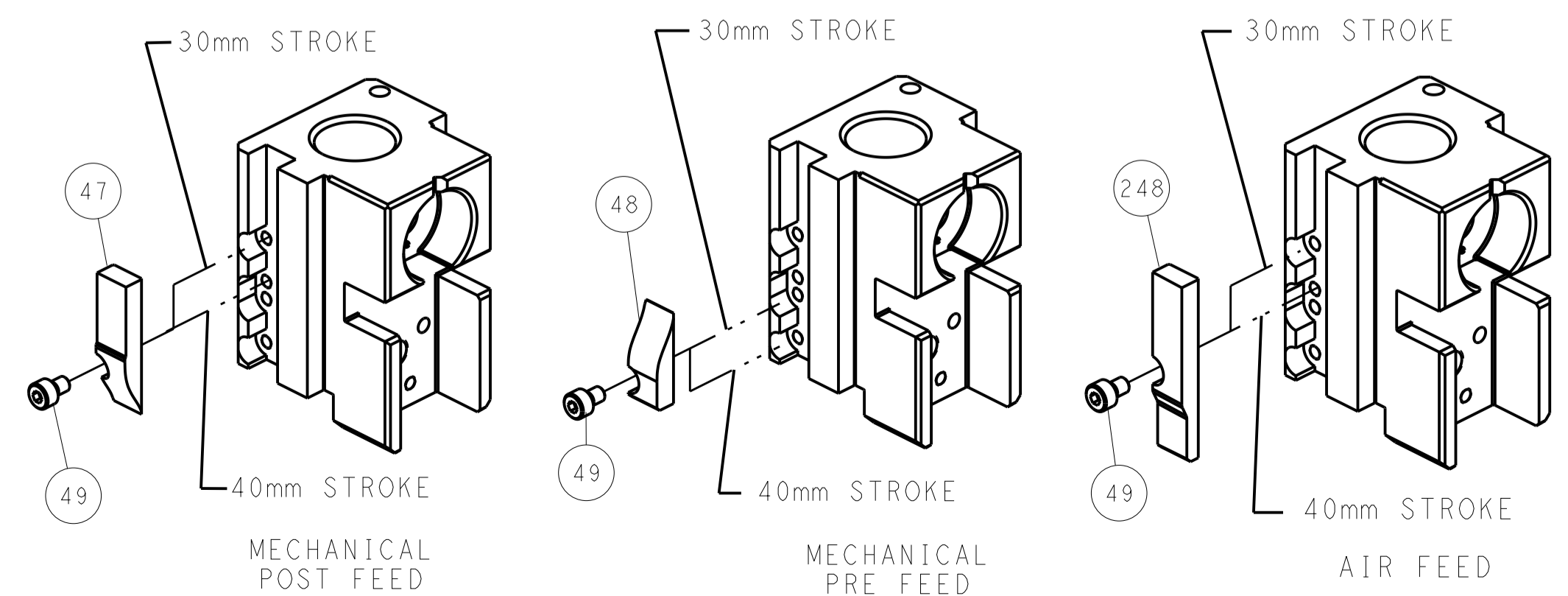

**ATLANTIC VERSION**  
 Shown on sheets 1 of 4 & 2 of 4  
 (Pacific version shown on sheets 3 of 4 & 4 of 4)

DIMENSIONS:		TOLERANCES UNLESS OTHERWISE SPECIFIED:		DWN: Y. YIN 21JAN2014		TE Connectivity	
mm	0 PLC ±0.5	1 PLC ±0.5	2 PLC ±0.13	3 PLC ±0.013	4 PLC ±0.0013	APVD: G. BAILEY 21JAN2014	Harrisburg, PA 17105-3608
MATERIAL:		FINISH:		NAME: Ocean Side Feed Applicator		RESTRICTED TO:	
				SIZE: A11		CAGE CODE: 00779	
				DRAWING NO: 2266199		SCALE: 1:2	
				SHEET: 2 of 4		REV: A	

PACIFIC VERSION TERMINATOR INTERFACE ADAPTER	PART NUMBER	REVISION	DESCRIPTION	FEED TYPE	APPLICATOR STYLE CONVERSION CHART						
					CONVERT TO	PART NUMBERS REQUIRED					
	2-2266199-1	A	FINE CRIMP HEIGHT ADJUST	MECHANICAL	PNEUMATIC FEED	2119950-1	1338685-1	5-18022-5	2119641-2	2119799-1	2063440-1
					SERVO LATCH PLATE	2119951-1	-	8-2266199-5	1901094-3	-	2168400-6 (QUANTITY 2)
					SMART APPLICATOR	2161326-1	-	8-2266199-4	-	-	-
	2-2266199-2	A	FINE CRIMP HEIGHT ADJUST	PNEUMATIC	MECHANICAL FEED	2119949-1	1338685-1	5-18022-5	2119653-2	-	-
					SERVO LATCH PLATE	2119951-1	-	8-2266199-5	1901094-3	-	2168400-6 (QUANTITY 2)
					SMART APPLICATOR	2161326-1	-	8-2266199-4	-	-	-
	2-2266199-5	A	FINE CRIMP HEIGHT ADJUST	SERVO LATCH PLATE <sup>4</sup>	MECHANICAL FEED	2119949-1	1338685-1	5-18022-5	2119653-2	-	-
					PNEUMATIC FEED	2119950-1	1338685-1	5-18022-5	2119641-2	2119799-1	2063440-1
	2-2266199-7	A	FINE CRIMP HEIGHT ADJUST	NONE	-	-	-	-	-	-	-
	7-2266199-7	A	CRIMP TOOLING KIT	-	-	-	-	-	-	-	-

APPLICATOR DATA		
CRIMP	SIZE	TYPE
WIRE	2.59 mm [1.02]	F
INSUL	3.60 mm [1.42]	OV
APPLICATOR INSTRUCTIONS 408-10389		

TERMINAL DATA: G&H TERMINAL		G&H CRIMP SPECIFICATION	
TERMINAL NAME: AFK FEMALE TERMINAL 2.8 X 0.8			
WIRE STRIP LENGTH		INSULATION DIAMETER RANGE	
4.70-5.30 mm [1.85-.209 IN]		Ø1.90-2.90 mm [0.075-.114 IN]	
TERMINAL APPLICATION SPECIFICATION	G&H Spec Rev 10	-	-
TERMINALS APPLIED			
TE TERMINAL	G&H TERMINAL	TE TERMINAL	G&H TERMINAL
1949035-1	26705.201.185	1949034-1	26657.330.185
1949035-2	26705.201.702	1949034-2	26657.201.142
		1949034-3	26657.201.702

WIRE SIZE	CRIMP HEIGHT mm [INCH]	CRIMP HEIGHT REFERENCE SETTING
2.50mm <sup>2</sup>	1.70+/-0.05 [1.067+/-0.002]	5.6
2.25mm <sup>2</sup>	1.60+/-0.05 [1.063+/-0.002]	6.6
1.50mm <sup>2</sup>	1.45+/-0.05 [1.057+/-0.002]	8.1

- RECOMMENDED SPARE PARTS
- GREASE BEARING SURFACES LIGHTLY
- 3. LUBRICATE DAILY PER THE APPLICATOR INSTRUCTION SHEET SUPPLIED WITH THE APPLICATOR.
- APPLICATOR SPECIFIC DATA TO BE ENTERED INTO BLANK MEMORY CHIP AT ASSEMBLY. SEE BELOW FOR PART NUMBER:  
 MECHANICAL FEED WITH "SMART APPLICATOR" CONVERSION: 8-2266199-4  
 PNEUMATIC FEED WITH "SMART APPLICATOR" CONVERSION: 8-2266199-4  
 SERVO FEED WITH "FINE CRIMP HEIGHT ADJUST": 8-2266199-5
- 5. ADJUSTMENT OF THE STRIPPER MAY BE REQUIRED WHEN MOVING THE APPLICATOR BETWEEN BENCH AND LEADMAKER APPLICATIONS.
- APPLY PART NUMBER 1-23419-5 LOCTITE TO THREADS OF ITEMS 62 & 242.
- GREASE THREADS, GROOVE AND O-RING ON ITEMS 139 & 152.
- MAGNET MUST BE ORIENTED CORRECTLY IN ORDER TO PROPERLY ACTUATE THE COUNTER.
- CRIMP HEIGHT REFERENCE SETTING WAS THE SETTING USED WHEN THE APPLICATOR WAS QUALIFIED AT THE FACTORY. ADJUSTMENT MAY BE NECESSARY WHEN RUNNING APPLICATOR IN THE FIELD.
- SPARE FEED CAM STORAGE LOCATION REFER TO INSTRUCTION SHEET FOR ADDITIONAL INFORMATION.
- TO CONVERT THE APPLICATOR TO A NON-CARRIER CUTTING STYLE, REMOVE ITEM 13 AND ATTACH TO THE LOCATION ON BACK SIDE OF THE HOUSING. REFER TO INSTRUCTION SHEET FOR ADDITIONAL INFORMATION.
- THIS APPLICATOR IS SPECIFIC FOR USE IN A STRIPPER SEAL TERMINATING UNIT.
- FOR SINGLE OR DOUBLE WIRE COMBINATIONS.
- FOR MULTIPLE WIRE COMBINATIONS ONLY.

**\*WARNING**  
 ON INSTALLATION, SET WIRE DISC, ITEM 40 TO LARGEST WIRE SIZE SETTING. USE OF SETTINGS BELOW MINIMUM REQUIRED CRIMP HEIGHT SETTING WILL CAUSE DAMAGE TO CRIMP TOOLING.

-	1	1	1	1	2119782-1	FINE ADJUST HEAD ASM, PACIFIC STYLE	251
-77	-27	-25	-22	-21	PART NO	DESCRIPTION	ITEM NO

**PACIFIC VERSION**  
 Shown on sheets 3 of 4 & 4 of 4  
 (Atlantic version shown on sheets 1 of 4 & 2 of 4)

SET UP GAUGE	LOC	DIST	REVISIONS			
2119599-1	A	66	REV	DATE	BY	APPV
			-	SEE SHEET 1	-	-

-	-	-	1	-	2119640-1	PUSH ROD, AIR FEED	250
-	-	-	1	-	2079988-1	BUSHING, LCH5-12, MISUMI	249
-	1	1	1	1	1-22279-3	SPRING, COMPRESSION	246
-	1	1	1	1	2119082-4	CAM, SNAIL, INSULATION ADJUSTMENT	244
-	1	1	1	1	2079764-1	WASHER, WAVE SPRING, CREST-TO-CREST	243
-	1	1	1	1	2119083-1	RETAINER, INSULATION DIAL	242
-	1	1	1	1	7-18023-7	SCR, SKT HD CAP M3 X 4.0	241
-	-	2	-	-	2168400-6	SHCS, LOW HEAD, RoHS, M5 X 16	240
-	-	-	-	1	2119580-1	MECHANICAL FEED ASSEMBLY	239
-	-	-	-	1	2063440-1	AIR FEED MODULE	238
-	-	1	-	-	2119740-2	TAG, IDENTIFICATION	213
-	-	1	-	-	1901094-3	SPACER, FEEDER	198
-	-	-	2	-	21045-3	RING, RETAIN, EXTERN, 3/16 CRESCENT	172
-	1	1	1	1	994969-1	MAGNET, RARE EARTH HIGH ENERGY	166
-	REF	REF	REF	REF	994970-2	COUNTER, MAGNETIC	164
-	-	-	1	-	240638-1	SPRING, FEED FINGER	163
-	1	1	1	1	8-21084-1	O-RING, .801 ID, .070 DIA. MAT.	152
-	-	-	-	1	2119641-2	FEED CAM, AIR FEED	151
-	1	1	1	1	2119798-2	DETENT PIN	145
-	1	1	1	1	2079383-8	SCR, BHSC, RoHS (M4 X 16)	144
-	4	4	4	4	2168400-5	SHCS, LOW HEAD, RoHS, M4 X 20	143
-	-	-	-	1	2119653-2	FEED CAM, POST FEED	142
-	1	1	1	1	2-2119656-2	APPLICATOR BASIC ASSEMBLY, SF	141
-	1	1	1	1	2119650-1	RAM, ASIAN STYLE, SIDE FEED	140
-	1	1	1	1	2119092-2	BOLT, ADJUSTMENT	139
-	-	-	-	1	3-23627-7	PIN, RETAIN, GRVD, 3/16 X .854	137
-	-	-	-	1	2119799-1	HOLDER, FEED FINGER, AF	136
-	-	REF	-	-	-	SEE NOTE 4	135
-	-	1	-	-	1633743-1	SERVO FEED LATCH ASM	133
-	1	1	1	1	1-18028-2	WASHER, FLAT, REG M4	119
-	-	REF	-	-	2119944-1	FEED FINGER ASSEMBLY, SF	117
-	1	1	1	1	455888-6	SPACER, CRIMPER	82
-	1	1	1	1	2119956-1	DOCUMENTATION PACKAGE	71
-	1	-	-	1	2119740-1	TAG, IDENTIFICATION	67
-	2	2	2	2	2168078-1	SCREW, DRIVE, RH, RoHS, 2 x .188	66
-	1	1	1	1	2119793-1	LIMITER, ADJUSTMENT BOLT	63
-	3	3	3	3	992763-5	SCR, SET, SOC, CONE POINT, M3 x 4.0	62
-	-	-	-	1	5-18022-5	SCR, HEX HD CAP, M4 X 6.0	59
-	-	-	-	1	1338685-1	PAWL, FEED	56
-	2	2	2	2	1-2168083-0	SCR, SKT HD CAP, RoHS, M4 X 10	53
-	1	1	1	1	5018030-1	NUT, HEX, REG, RoHS, M3	52
-	1	1	1	1	811242-5	BUMPER, HOLD DOWN	51
-	1	1	1	1	690753-2	SPACER, TONKER	50
-	-	-	-	1	18023-9	SCR, SKT HD CAP M4 X 6.0	49
-	-	-	-	1	2119652-1	FEED CAM, PRE FEED	48
-	1	1	1	1	2079383-7	SCR, BHSC, RoHS (M8 X 25)	41
-	1	1	1	1	2119645-1	DISC, NUMBERED FA WIRE ADJUSTMENT	40
-	1	1	1	1	2119957-1	APPLICATOR SHIM PACK	39
-	1	1	1	1	1-2119644-2	RAM WASHER, PRECISION	38
-	1	1	1	1	1-1752356-7	SUPPORT, TERMINAL	34
-	2	2	2	2	2079383-5	SCR, BHSC, RoHS (M4 X 20)	33
-	1	1	1	1	2161328-1	HEX HEAD, FLANGED, M5 x 8mm LONG	32
-	1	1	1	1	1320908-7	SPACER, STRIP GUIDE	30
-	1	1	1	1	2119959-4	ASSEMBLY, STRIP GUIDE	29
-	1	1	1	1	455888-3	SPACER, CRIMPER	28
-	1	1	1	1	240792-1	DRAG, TERMINAL	25
-	1	1	1	1	1320928-2	STRIP GUIDE	24
-	1	1	1	1	2168083-2	SCR, SKT HD CAP, RoHS, M4 X 8.0	21
-	1	1	1	1	1-18028-2	WASHER, FLAT, REG M4	20
-	1	1	1	1	2119533-1	STRIPPER, SIDE FEED	19
-	1	1	1	1	2119806-1	INSERT, SHEAR	13
-	1	1	1	1	3-22280-3	SPRING, COMPRESSION	12
-	1	1	1	1	1-356885-4	STOP, SHEAR	11
-	1	1	1	1	2119805-1	SHEAR HOLDER, FRONT	10
-	1	1	1	1	318707-1	FLOATING SHEAR, FRONT	9
-	1	1	1	1	7-1633927-3	ANVIL, COMBINATION	8
-	-	-	-	-	-	-	7
-	-	-	-	-	-	-	6
-	1	1	1	1	2119757-8	DEPRESSOR, SHEAR	5
-	1	1	1	1	2-238011-2	BLOCK, CRIMPER SPACER	4
-	1	1	1	1	1-1633963-6	CRIMPER, INSULATION OVERLAP PREMIUM	3
-	1	1	1	1	455888-1	SPACER, CRIMPER	2
-	1	1	1	1	3-1633305-3	CRIMPER, WIRE PREMIUM	1

DIMENSIONS:		TOLERANCES UNLESS OTHERWISE SPECIFIED:		DATE	BY	APPV	NAME
mm	0 PLC ±0.5	1 PLC ±0.5	2 PLC ±0.13	21JAN2014	Y. YIN	21JAN2014	TE Connectivity
	3 PLC ±0.013	4 PLC ±0.001	ANGLES ±0.001	21JAN2014	G. BAILEY	21JAN2014	Harrisburg, PA 17105-3608
MATERIAL:	FINISH:	WEIGHT:	SCALE:	Customer Accessible Production Drawing		SHEET 3 OF 4	REV A

LOC		DIST		REVISIONS			
A	66	P	LTM	DESCRIPTION	DATE	DWN	APVD
		-	-	SEE SHEET 1	-	-	-

# FEED TYPE MECHANICAL

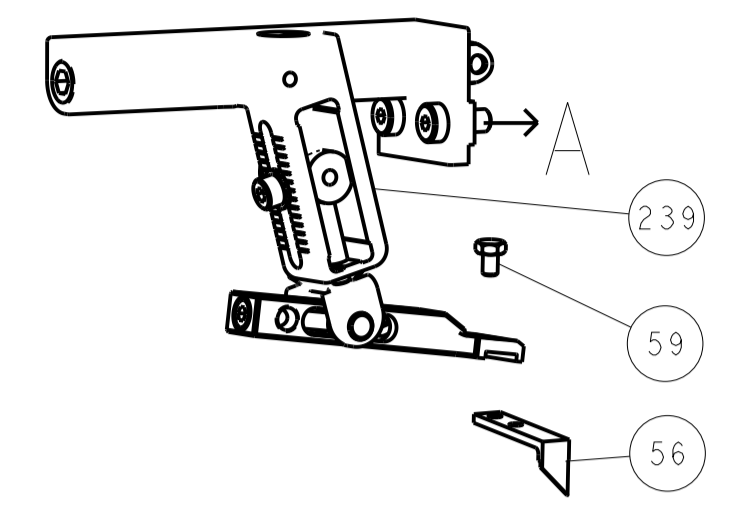

# PNEUMATIC

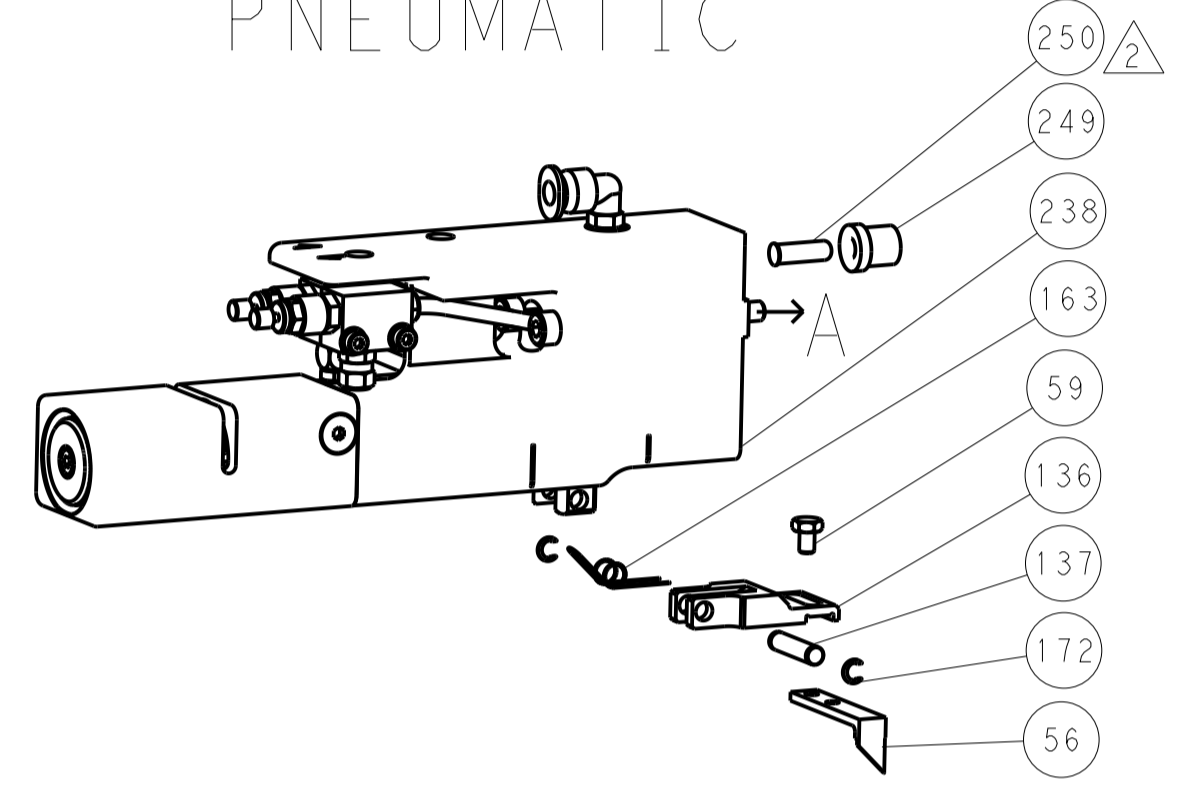

# SERVO LATCH PLATE

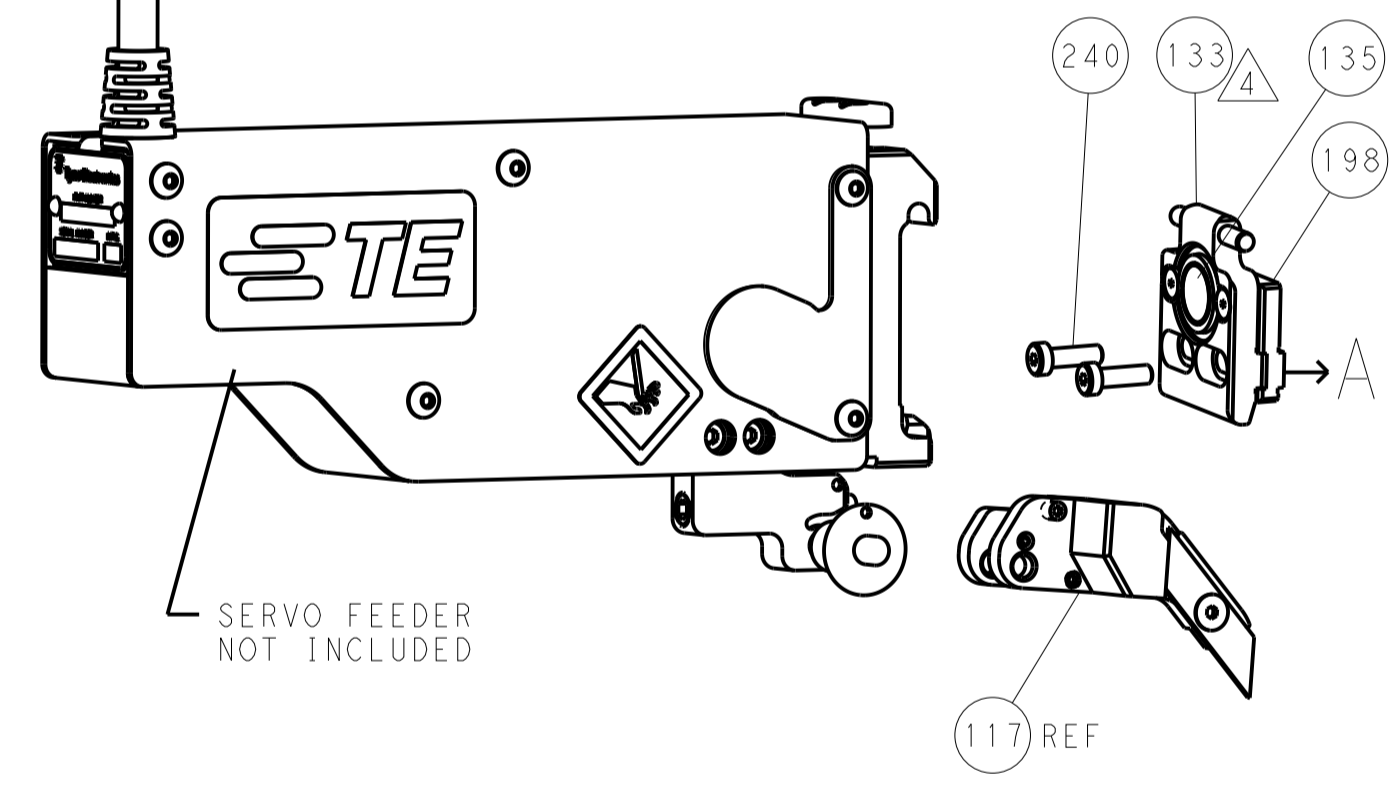

# CAM POSITIONS

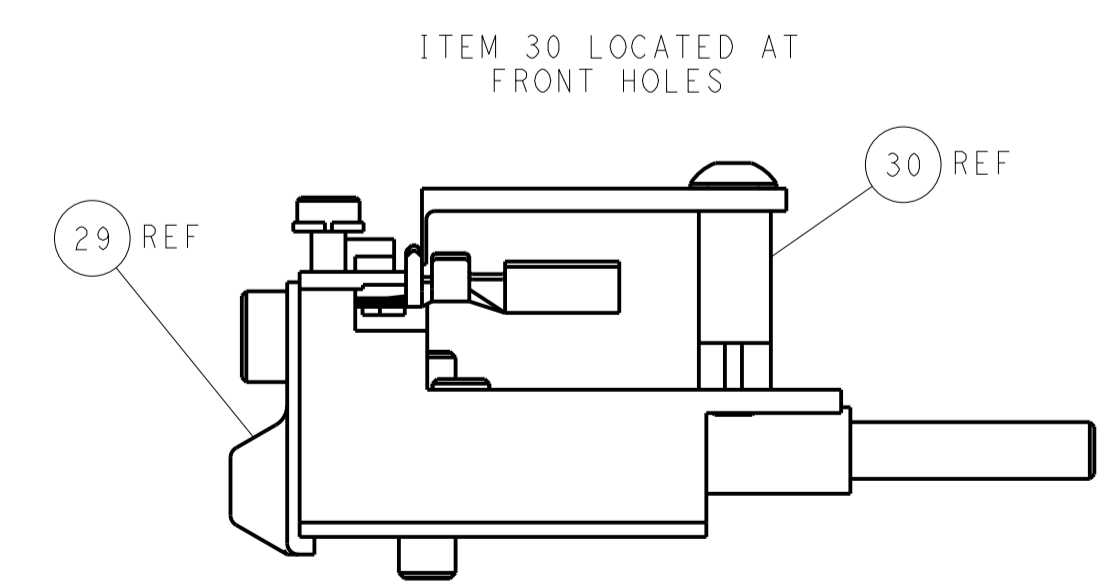
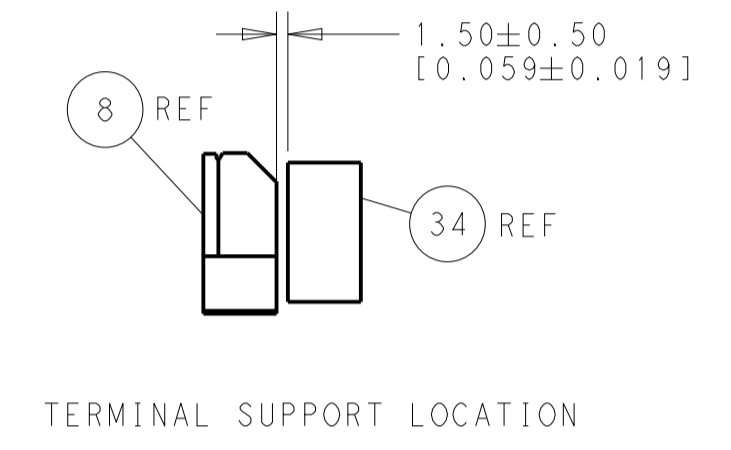
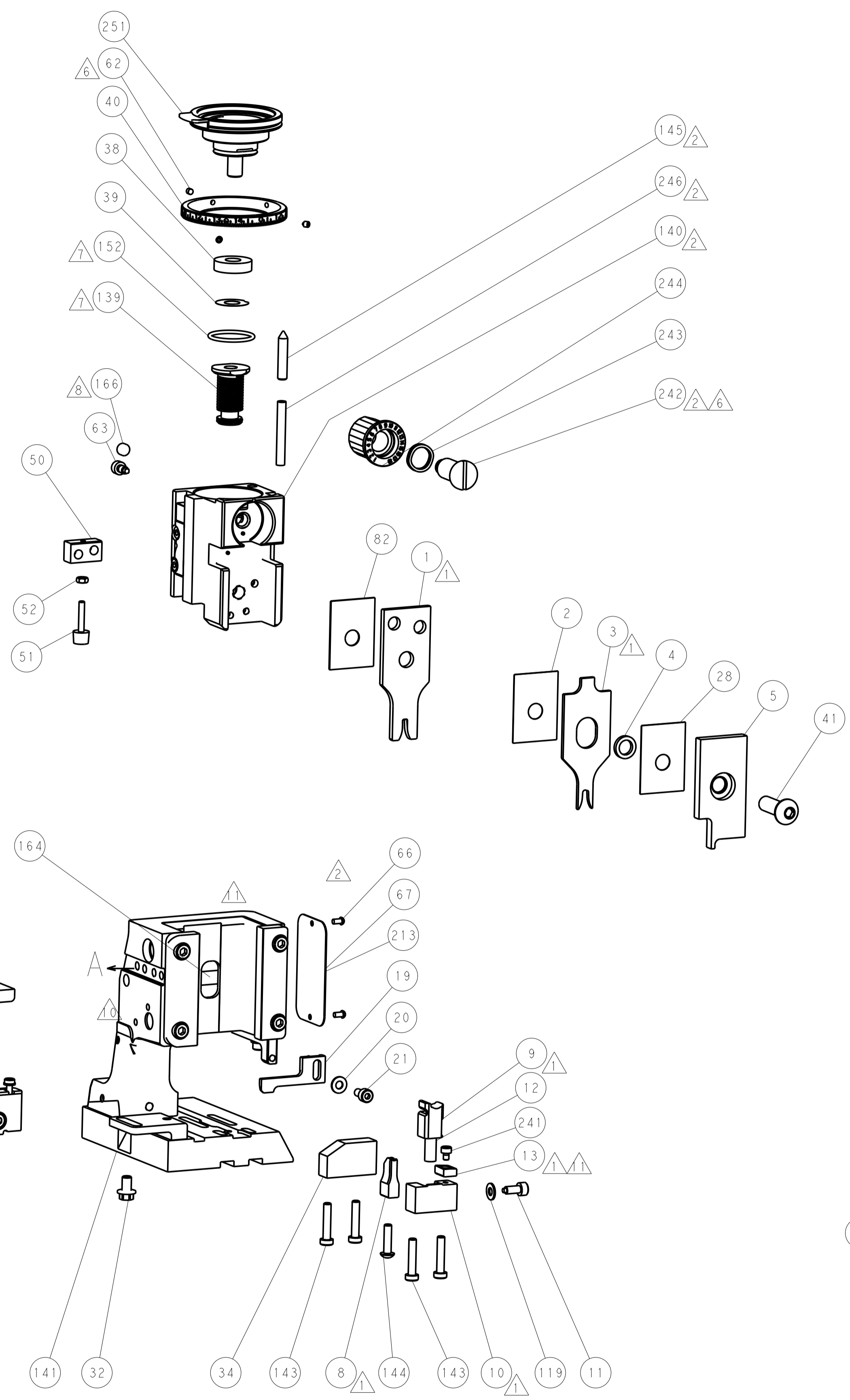
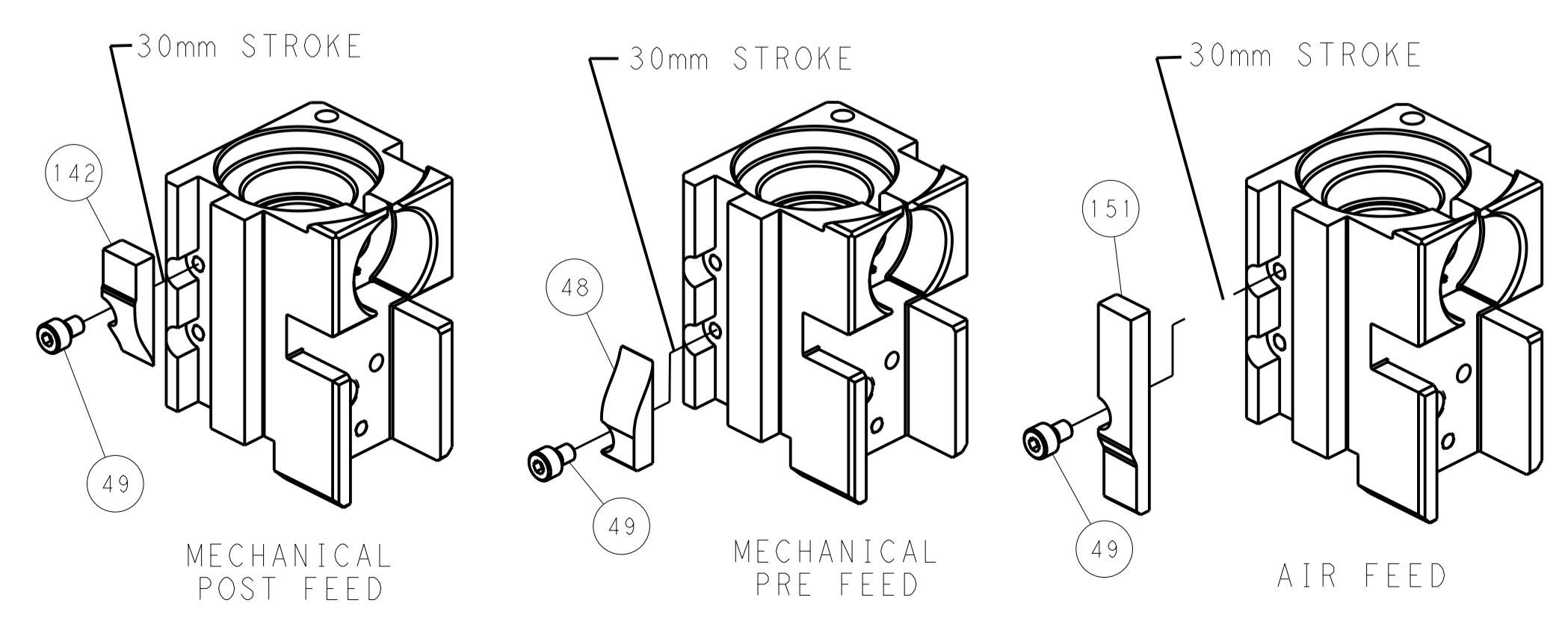

**PACIFIC VERSION**  
 Shown on sheets 3 of 4 & 4 of 4  
 (Atlantic version shown on sheets 1 of 4 & 2 of 4)

DIMENSIONS:		TOLERANCES UNLESS OTHERWISE SPECIFIED:		DWN Y. YIN 21JAN2014		TE Connectivity Harrisburg, PA 17105-3608	
mm	0 PLC ±0.5	1 PLC ±0.5	2 PLC ±0.13	3 PLC ±0.013	4 PLC ±0.001	NAME Ocean Side Feed Applicator	RESTRICTED TO
MATERIAL	FINISH	WEIGHT	APVD G. BAILEY 21JAN2014	PRODUCT SPEC	APPLICATION SPEC	SIZE A	Customer Accessible Production Drawing
SCALE 1:2		SHEET 4 OF 4		REV A		CAGE CODE DRAWING NO 00779 ©=2266199	