



## UD05021

CMOS IC

### 2.0A 1.5MHZ SYNCHRONOUS BUCK CONVERTER

#### DESCRIPTION

The UTC **UD05021** is a monolithic synchronous buck regulator with a built in internal power MOSFET. It achieves 2A continuous output current fix switching frequency with excellent load and line regulation.

Current mode operation provides fast transient response and eases of loop stabilization.

Fault condition protection includes cycle-by-cycle current limiting, output short circuit protection and thermal shutdown. In shutdown mode the regulator draws less than 1µA of supply current. Internal soft-start minimizes the inrush supply current at initial startup.

#### FEATURES

- \* 2.5V~5.5V input voltage range
- \* Up to 2A Output Current
- \* 150/120mΩ Internal Power MOSFET Switch
- \* Stable with Low ESR Output Ceramic Capacitors
- \* Up to 95% Efficiency
- \* Less than 1µA Shutdown Current
- \* 1.5Mhz Switching Frequency
- \* Thermal Shutdown Protection
- \* Current limit and short circuit protections.
- \* Output Adjustable from 1V to  $V_{IN}$
- \* Build-in soft start function

#### ORDERING INFORMATION

Ordering Number	Package	Packing
UD05021G-AF5-R	SOT-25	Tape Reel

	<p>(1) Packing Type</p> <p>(2) Package Type</p> <p>(3) Green Package</p>	<p>(1) R: Tape Reel</p> <p>(2) AF5: SOT-25</p> <p>(3) G: Halogen Free and Lead Free</p>
--	--	---

#### MARKING

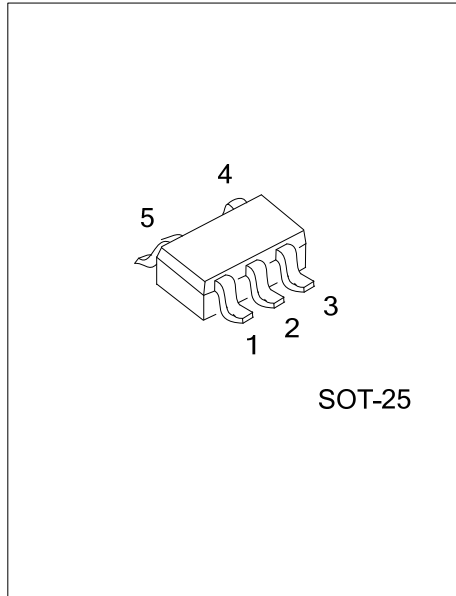
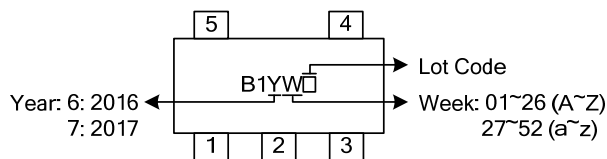

## PIN CONFIGURATION

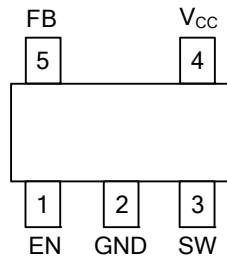

## PIN DESCRIPTION

PIN NO.	PIN NAME	DESCRIPTION
1	EN	Chip enable pin. Active high.
2	GND	Ground pin
3	SW	Switching pin
4	V <sub>CC</sub>	V <sub>CC</sub> input pin
5	FB	Feedback pin

## BLOCK DIAGRAM

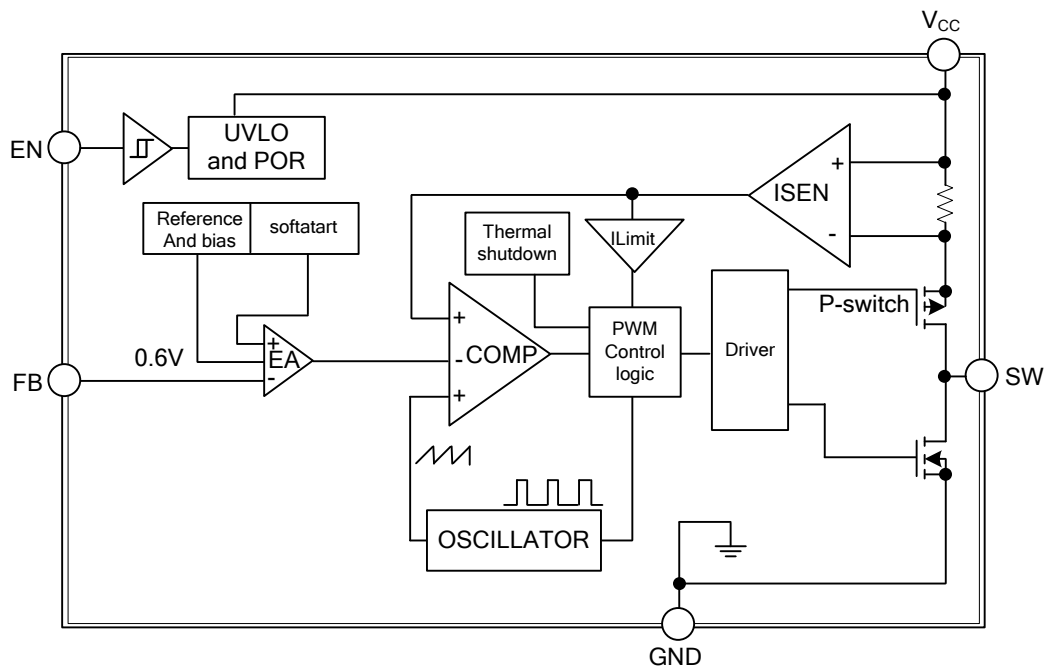

■ ABSOLUTE MAXIMUM RATING ( $T_A=25^\circ\text{C}$ , unless otherwise specified)

PARAMETER	SYMBOL	RATINGS	UNIT
$V_{CC}$ Pin Voltage	$V_{IN}$	-0.3~7	V
SW Pin Voltage	$V_{SW}$	-0.7 ~ $V_{IN}+0.3$	V
EN, FB Pins Voltage		-0.3 ~ $V_{IN}+0.3$	V
Continuous Power Dissipation	$P_D$	$(T_J-T_A)/\theta_{JA}$	mW
Junction Temperature	$T_J$	-40 ~ +125	$^\circ\text{C}$
Storage Temperature	$T_{STG}$	-65 ~ +150	$^\circ\text{C}$

Notes: 1. Absolute maximum ratings are those values beyond which the device could be permanently damaged. Absolute maximum ratings are stress ratings only and functional device operation is not implied.

2. Stresses exceed those ratings may damage the device.

■ THERMAL CHARACTERISTICS

PARAMETER	SYMBOL	RATINGS	UNIT
Junction to Ambient	$\theta_{JA}$	250	$^\circ\text{C}/\text{W}$
Junction to Case	$\theta_{JC}$	110	$^\circ\text{C}/\text{W}$

Note:  $\theta_{JA}$  is measured with the PCB copper are (need connect to GND of the UTC UD05021) of approximately  $1\text{ in}^2$  (Multi-layer).

■ ELECTRICAL CHARACTERISTICS ( $V_{IN}=5\text{V}$ ,  $V_{EN}=5\text{V}$ ,  $V_{OUT}=3.3\text{V}$ ,  $T_A=25^\circ\text{C}$ )

PARAMETER	SYMBOL	TEST CONDITIONS	MIN	TYP	MAX	UNIT
Input Voltage Range	$V_{IN}$		2.5		5.5	V
Input UVLO	UVLO	$I_{OUT}=0\text{A}$	1.8	2.2	2.5	V
Input OVLO	OVLO	$I_{OUT}=0\text{A}$		6.0		V
Quiescent Current	$I_{CCQ}$	$V_{EN}=1\text{V}$		250	350	$\mu\text{A}$
Shutdown Current	$I_{SD}$	$V_{EN}=0\text{V}$		0.1	1	$\mu\text{A}$
FB Pin Voltage	$V_{FB}$		0.588	0.6	0.612	V
FB Pin Current (Note)	$I_{FB}$				$\pm 50$	nA
Load Regulation		$0\text{A}<I_{OUT}<1.5\text{A}$		0.6		%
Load Regulation		$2.5\text{V}<V_{IN}<5.5\text{V}$		0.3		%/V
EN Pin Voltage High	$V_{ENH}$		1.5			V
EN Pin Voltage Low	$V_{ENL}$				0.4	V
EN Pin Leakage Current		$V_{EN}=3\text{V}$		0.1	1	$\mu\text{A}$
Switching Frequency	$F_{OSC}$		1.1	1.5	1.9	MHz
Current Limit	$C_L$	$V_{IN}=3\text{V}$ , $V_{FB}=0.5\text{V}$ or $V_{OUT}=90\%$ , Duty Cycle<35%	2.2	2.5		A
Switching Maximum Duty	Dmax				100	%
Minimum Duty	Dmin		0			%
P-Switch $R_{DS(ON)}$	$R_{DS(ON)-P}$			150		m $\Omega$
N-Switch $R_{DS(ON)}$ (Note)	$R_{DS(ON)-N}$			120		m $\Omega$
Low Side Discharger				60		$\Omega$
Thermal Shutdown	$T_{SD}$			155		$^\circ\text{C}$
Thermal Shutdown Protection hysteresis	$T_{SH}$			30		$^\circ\text{C}$

Note: Guaranteed by design.

## ■ TYPICAL APPLICATION CIRCUIT

$1.8V \leq V_{OUT} \leq 4.4V$

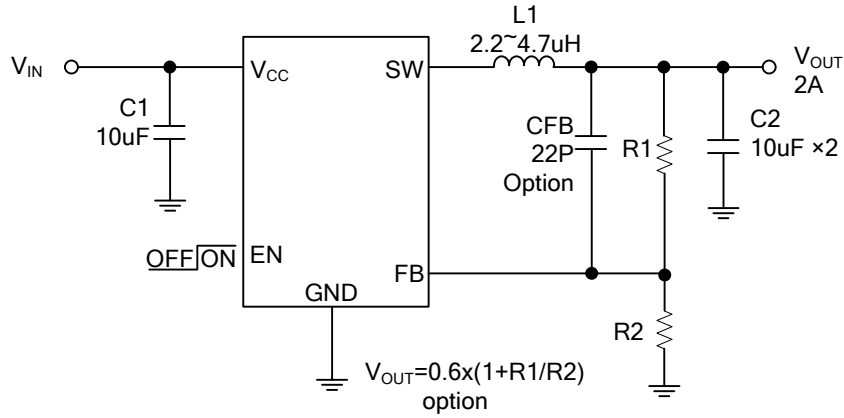

$V_{OUT} = V_{FB} \times (1 + R1/R2)$ ,  $V_{FB} = 0.6V$ ,  $R2$  suggest  $60k \sim 300k\Omega$

$1.0V \leq V_{OUT} \leq 1.6V$

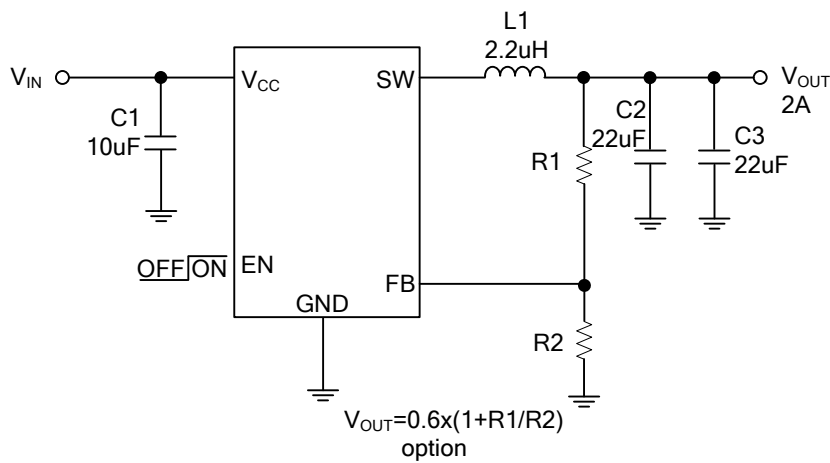

## ■ FUNCTION DESCRIPTION

### Normal Operation

The **UD05021** uses a user adjustable frequency, current mode, synchronous step-down architecture with internal power switch. During normal operation, the internal power switch is turned on each cycle when the oscillator sets the SR latch, and turned off when the comparator resets the SR latch. The peak inductor current at which comparator resets the SR latch is controlled by the output of error amplifier EA. While the high-side switch is off, the external schottky diode turns on until either the inductor current starts to reverse or the beginning of the next switching cycle.

### Dropout Operation

As the input supply voltage decreases to a value approaching the output voltage, the duty cycle increases toward the maximum on-time. Further reduction of the supply voltage forces the high-side switch to remain on for more than one cycle until it reaches 100% duty cycle.

The output voltage is dropped from the input supply for the voltage which across the high-side switch.

### Setting the Output Voltage

Application circuit item shows the basic application circuit with adjustable output version. The external resistor sets the output voltage according to the following equation:

$$V_{OUT} = V_{FB} \times (1 + R1 / R2), \quad V_{FB} = 0.6V, \quad R2 \text{ suggest } 60k\Omega \sim 300k\Omega$$

Table 1 Resistor select for output voltage setting

V <sub>OUT</sub>	R1	R2
1.0V	100K	150K
1.2V	100K	100K
1.5V	150K	100K
1.8V	200K	100K
2.5V	470K	150K
3.3V	450K	100K

### Over Temperature Protection

In most applications the **UD05021** does not dissipate much heat due to high efficiency. But, in applications where the **UD05021** is running at high ambient temperature with low supply voltage and high duty cycles, such as in dropout, the heat dissipated may exceed the maximum junction temperature of the part. If the junction temperature reaches approximately 155°C, the internal high-side power switch will be turned off and the LX node will become high impedance.

### Over Current Protection

The **UD05021** cycle-by-cycle limits the peak inductor current to protect embedded switch from damage. Hence the maximum output current (the average of inductor current) is also limited. In case the load increases, the inductor current is also increase. Whenever the current limit level is reached, the output voltage cannot be regulated and starting to drop.

### Soft-Start

The **UD05021** employs internal soft-start circuitry to reduce supply inrush current during startup conditions. When the device exits under-voltage lockout or shut-down mode, the soft-start circuitry will slowly ramp up the output voltage.

### Short-circuit Protection

Short-circuit protection will activate once the feedback voltage falls below, and the operating frequency will be reducing normal switching frequency to reduce power delivered from input to output.

■ TYPICAL CHARACTERISTICS

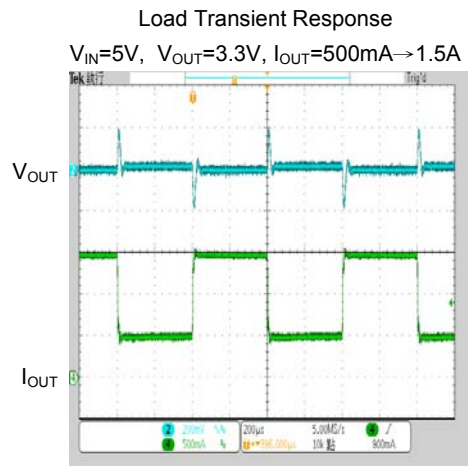
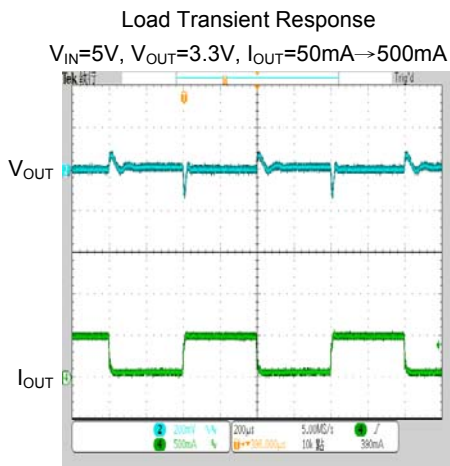
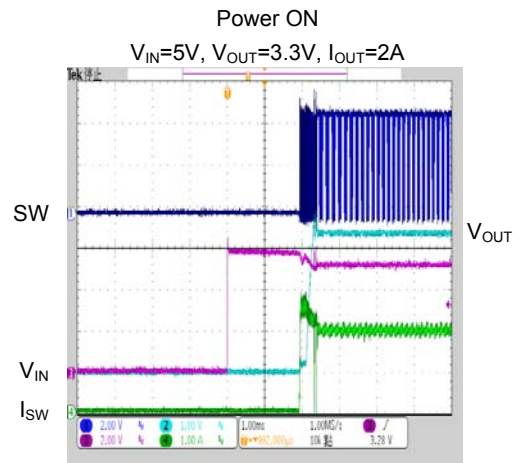
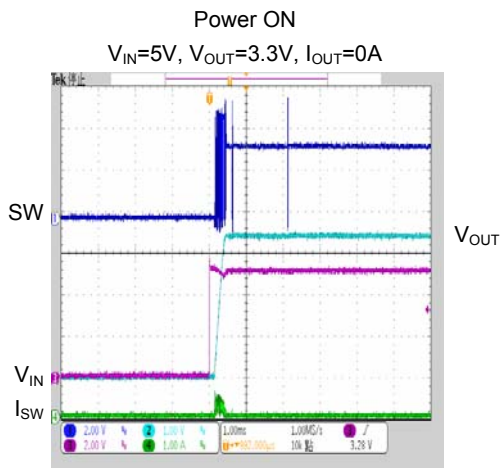
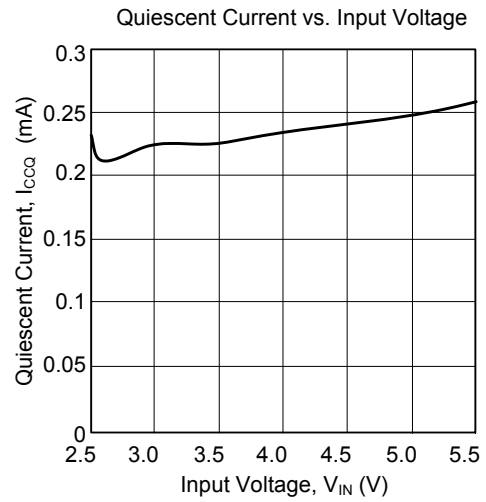
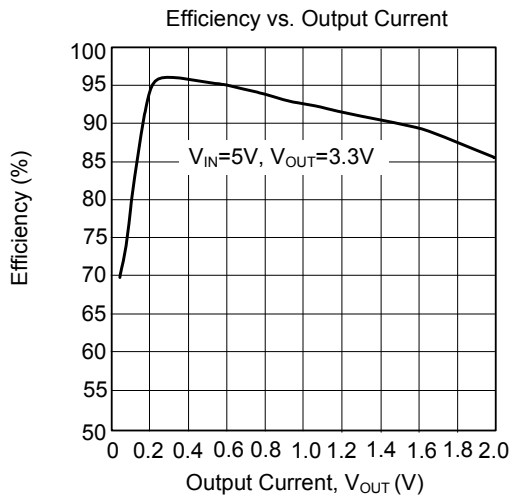

■ TYPICAL CHARACTERISTICS (Cont.)

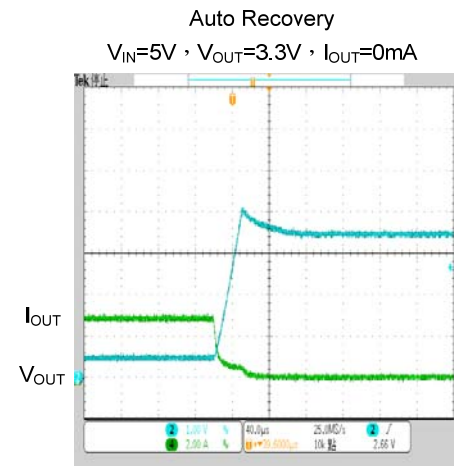
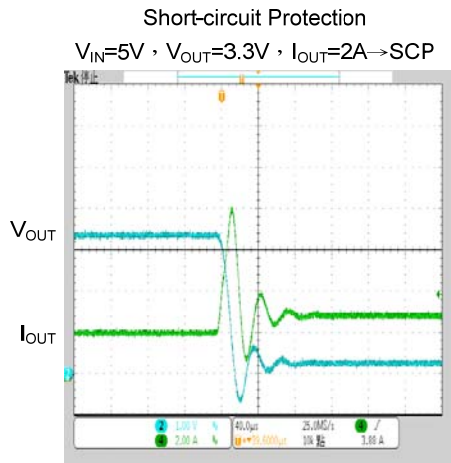
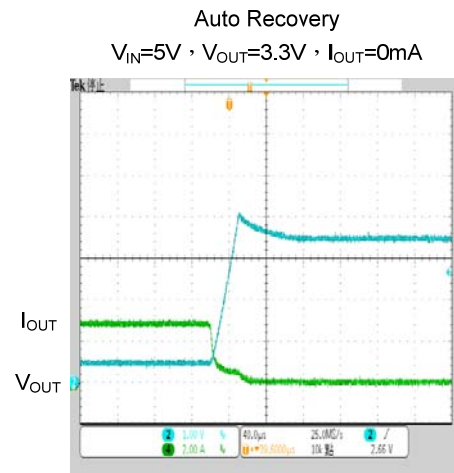
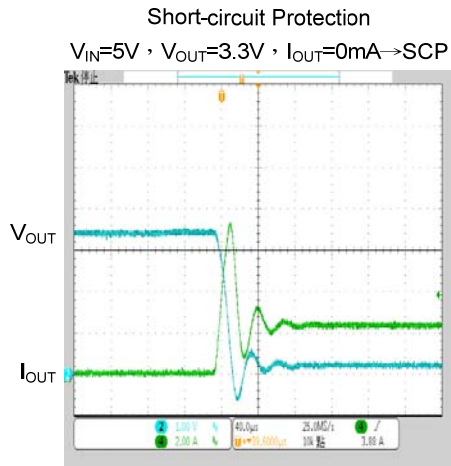

UTC assumes no responsibility for equipment failures that result from using products at values that exceed, even momentarily, rated values (such as maximum ratings, operating condition ranges, or other parameters) listed in products specifications of any and all UTC products described or contained herein. UTC products are not designed for use in life support appliances, devices or systems where malfunction of these products can be reasonably expected to result in personal injury. Reproduction in whole or in part is prohibited without the prior written consent of the copyright owner. The information presented in this document does not form part of any quotation or contract, is believed to be accurate and reliable and may be changed without notice.