

SPECIFICATION FOR APPROVAL

REF: 20090406-B

PAGE: 1

PROD. NAME	SMD LINE FILTER	ABC'S DWG NO. ABC'S ITEM NO.	SF3216□□□□L□-□□□
---------------	------------------------	---------------------------------	------------------

I . MECHANICAL DIMENSIONS :

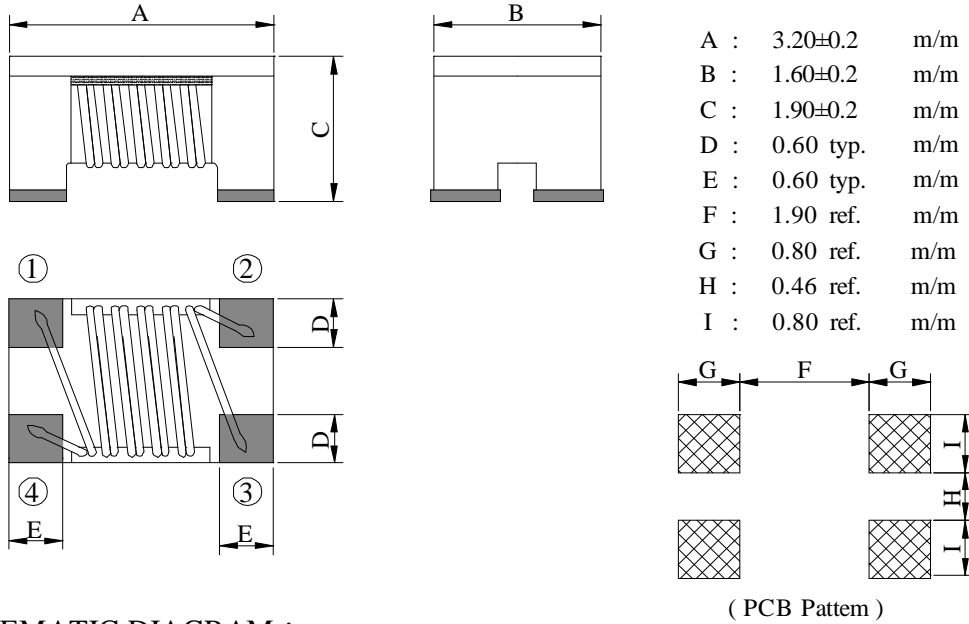

II . SCHEMATIC DIAGRAM :

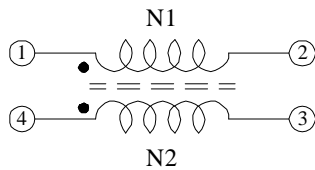

III . MATERIALS LIST :

- a . Core : Ferrite
- b . Wire : Enamelled copper wire (class F)
- c . Terminal : Ag / Ni / Sn
- d . Remark : Products comply with RoHS' requirements

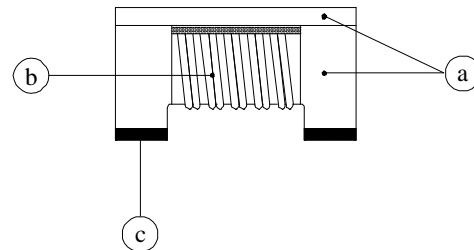

Peak Temp : 260°C max.
 Max time above 230°C : 50sec max.
 Max time above 200°C : 70sec max.

IV . GENERAL SPECIFICATION :

- a . Temp rise : 20°C max
- b . Rated current : Base on temp. rise
& ΔL/L0A=20% max.
- c . Storage temp. : -40°C ----+125°C
- d . Operating temp. : -40°C ----+125°C
(Temp. rise included)

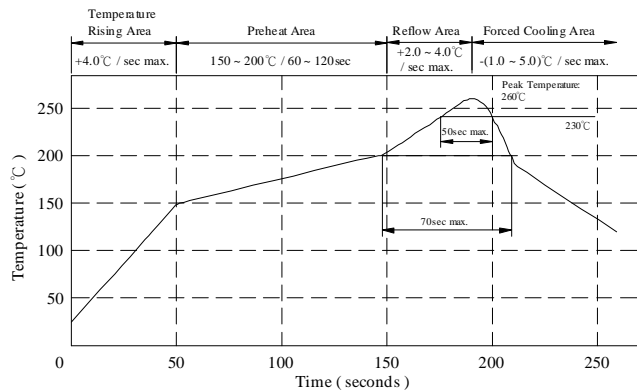

AR-001A

SPECIFICATION FOR APPROVAL

REF: 20090406-B

PAGE: 2

PROD. NAME	SMD LINE FILTER	ABC'S DWG NO.	SF3216□□□□L□-□□□
		ABC'S ITEM NO.	

V . ELECTRICAL CHARACTERISTICS :

Dwg. No.	Impedance (Ω) @ 100 MHz	Rated (DC) V	Withstanding (DC) V	Insulation Resistance ($M\Omega$) min.	RDC (Ω) max.	IDC (mA) max.
SF3216900YL□-□□□	90±25%	50	125	10	0.300	370
SF3216121YL□-□□□	120±25%	50	125	10	0.300	370
SF3216161YL□-□□□	160±25%	50	125	10	0.400	340
SF3216221YL□-□□□	220±25%	50	125	10	0.400	320
SF3216261YL□-□□□	260±25%	50	125	10	0.500	310
SF3216601YL□-□□□	600±25%	50	125	10	0.800	260
SF3216102YL□-□□□	1000±25%	50	125	10	1.000	230
SF3216222YL□-□□□	2200±25%	50	125	10	1.200	200

- 1). □ : Packaging information... A: Bulk B: Taping Reel
- 2). "-□□□": Reference code
- 3). Impedance Test Instrument : HP4291A.
- 4). RDC Test Instrument : CH-502AC.
- 5). IDC Test Instrument : CH1062+CH301A.

AR-001A



SPECIFICATION FOR APPROVAL

PROD. NAME	SMD LINE FILTER	ABC'S DWG NO.	SF3216□□□□L□-□□□
		ABC'S ITEM NO.	

VI . INSERTION LOSS Vs. FREQUENCY & IMPEDANCE Vs. FREQUENCY :

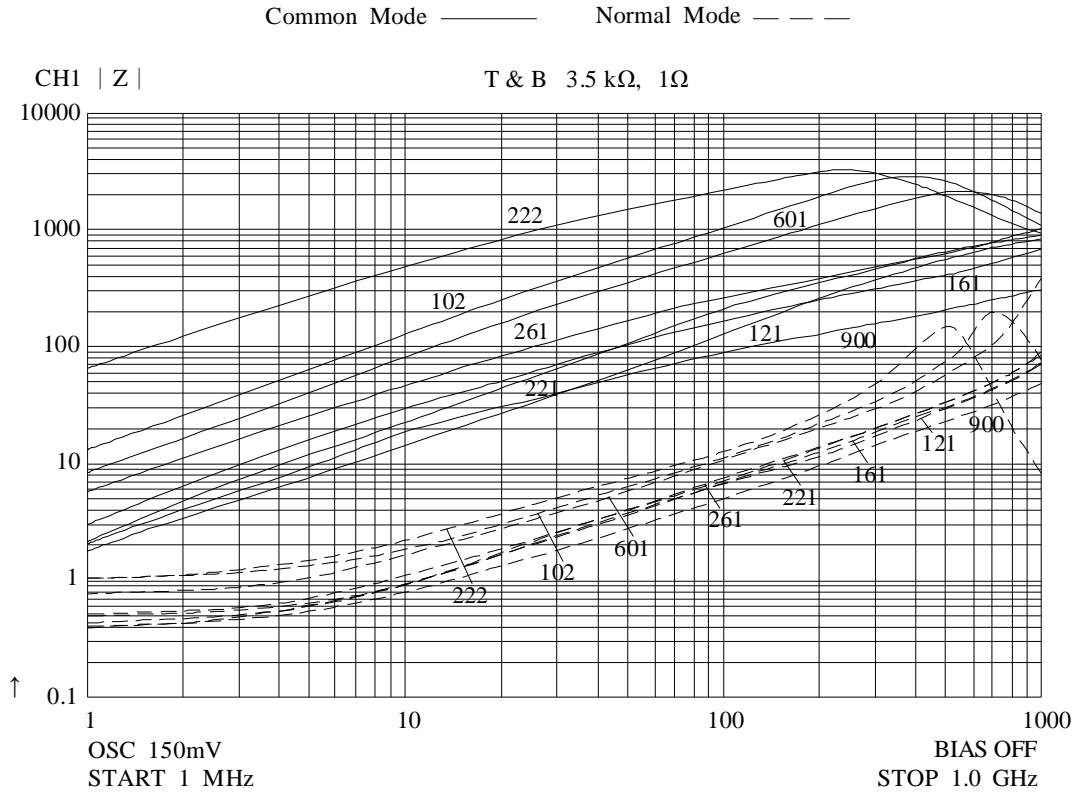

Z (f)	Common Mode							Normal Mode						
	1 MHz	3 MHz	10 MHz	30 MHz	100 MHz	300 MHz	1 GHz	1 MHz	3 MHz	10 MHz	30 MHz	100 MHz	300 MHz	1 GHz
900	2.04	4.35	10.43	40.1	89.7	165.1	317.2	0.398	0.465	0.792	1.824	4.984	15.925	49.432
121	1.82	4.92	10.52	30.9	142.3	371.5	834.6	0.438	0.509	0.917	2.458	6.845	18.852	69.935
161	3.08	9.45	28.52	69.3	176.5	312.4	685.2	0.421	0.394	0.953	2.453	6.756	19.521	72.415
221	2.35	6.91	23.85	68.3	225.6	462.8	894.5	0.495	0.586	1.052	2.569	7.358	20.364	86.589
261	5.91	18.26	51.23	125.3	285.6	498.5	1005.8	0.524	0.602	1.156	2.684	7.184	19.874	85.487
601	8.15	25.98	79.54	237.5	618.9	1687.5	1516.2	0.789	0.891	1.624	3.756	10.85	30.056	386.123
102	15.21	40.08	148.95	394.8	1005.2	2942.5	1124.6	1.054	1.268	1.925	1.482	13.542	37.254	75.648
222	68.54	185.23	501.23	1186.2	2203.6	3085.9	912.5	1.342	1.589	2.106	4.861	15.648	48.561	8.421

SPECIFICATION FOR APPROVAL

REF: 20090406-B

PAGE: 4

PROD. NAME	SMD LINE FILTER	ABC'S DWG NO.	SF3216□□□□L□-□□□
		ABC'S ITEM NO.	

VII . PACKAGING INFORMATION :

(1) Configuration

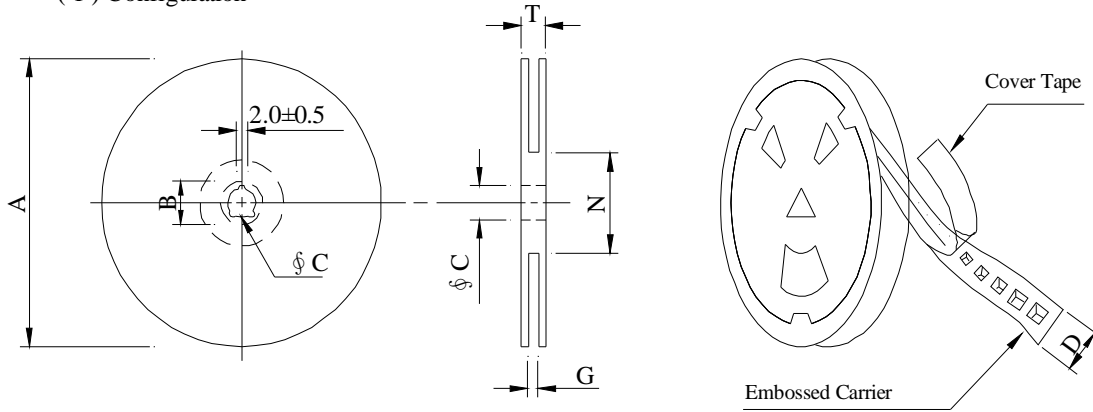

※Carrier Tape Width : D

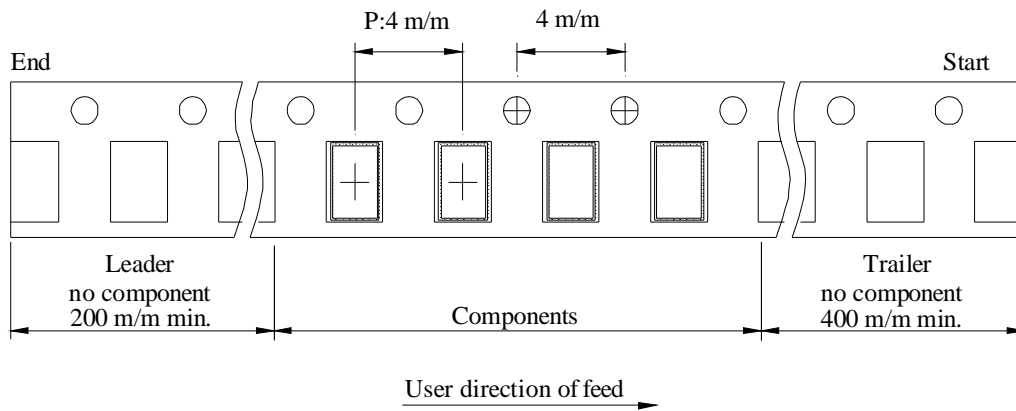

(2) Dimensions

Unit:m/m

Style	A	B	C	D	G	N	T
07 - 08	178	21±0.8	13	8	14 ⁺⁰	50 ⁻⁰	16.5

(3) Q'TY & G.W. Per package

Series	Inner : Reel			Outer : Carton		
	Q'TY (pcs)	G.W. (gw)	Style	Q'TY (pcs)	G.W. (Kg)	SIZE (cm)
SF3216	2,000	95	07 - 08	100,000	6.50	41 x 39 x 22

AR-001A

SPECIFICATION FOR APPROVAL

REF: 20090406-B

PAGE: 5

PROD. NAME	SMD LINE FILTER	ABC'S DWG NO.	SF3216□□□□L□-□□□
		ABC'S ITEM NO.	

VIII . DWGING NUMBER EXPRESSION :

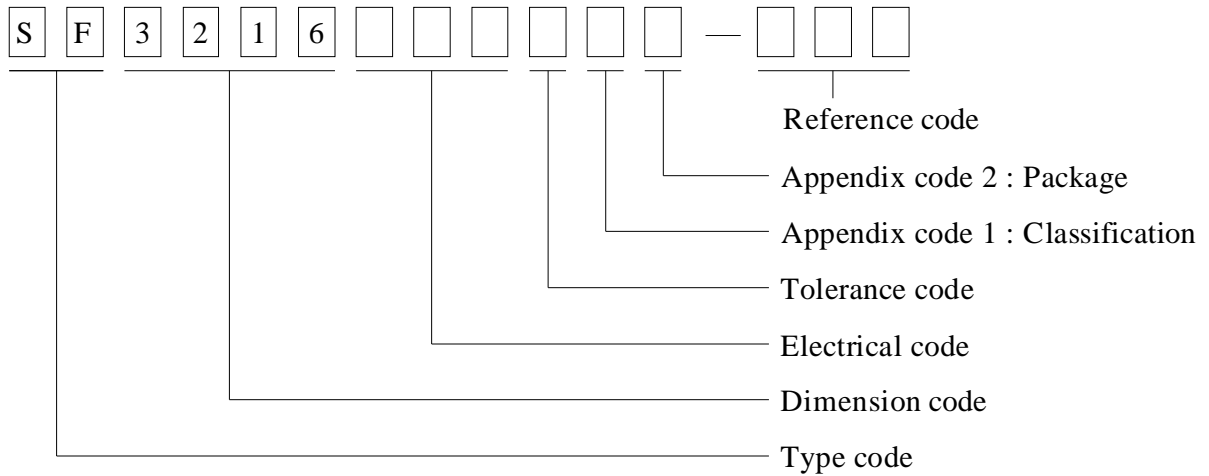

Appendix code 1 : Product Classification

- L : Lead Free Standard products comply with RoHS' requirements
- 1 ~ 9 : Lead Free Special products comply with RoHS' requirements

Appendix code 2 : Package Information

Code	Inner package	Inner package QTY	Remark
A	T.B.D.	T.B.D.	
B	T / R (Reel package)	2000 pcs	

AR-001A



SPECIFICATION FOR APPROVAL

REF: 20090406-B

PAGE: 6

PROD. NAME	SMD LINE FILTER	ABC'S DWG NO.	SF3216□□□□L□-□□□
		ABC'S ITEM NO.	

IX . RELIABILITY TEST :

1-1.Environmental Performance

No	Item	Specification	Test Method		
1-1-1	Temperature Cycle	Appearance: No Damage Impedance: within±20% of initial value	One cycle:		
			Step	Temperature (°C)	Time (min)
			1	-25±3	30
			2	25±2	3
			3	85±3	30
			4	25±2	3
1-1-2	Humidity Resistance		Total: 5 cycles Measured After Exposure in The Room Condition For 1hrs Temperature: 40±2°C Relative Humidity: 90 ~ 95% Time: 100hrs Measured After Exposure In The Room Condition For 1hrs		
1-1-3	High Temperature Resistance		Temperature: 85±3°C Time: 50Hrs Measured After Exposure In The Room Condition For 1Hrs		
1-1-4	Low Temperature Resistance		Temperature: -25±3°C Time: 50Hrs Measured After Exposure In The Room Condition For 1Hrs		
1-1-5	High Temperature Load Life		Temperature: 85±3°C Load: Allowed DC Current Time: 500Hrs		
1-1-6	Humidity Load Life	Temperature: 40±2°C Relative Humidity: 90~95% Load: Allowed DC Current Time: 500Hrs			

1-2.Mechanical Performance

No	Item	Specification	Test Method
1-2-1	Resistance To Soldering Heat	Appearance: No Damage	1. The Device Should Be Reflow soldered on PCB (peak 260°C±5°C For 10 Seconds) 2. Solder Composition: Sn/Ag3.0/Cu0.5 3. Test Time: 6 minutes
1-2-2	Solder ability	The Electrodes Shall Be At Least 90% Covered with New Solder Coating	1. Pre-Heating: 150°C, 1min. 2. Solder Composition: Sn/Ag3.0/Cu0.5 3. Solder Temperature: 245±5°C. 4. Immersion Time: 4±1 sec.
1-2-3	Compponent Adhesion (Push Test)	2 Lbs	The device should be reflow soldered (230±5°C For 10 seconds) to a tinned copper substrate. A force guauge should be applied to the side of the component. The device must withstand a minimum force of 2 pounds without a failure of the termination attached to component

AR-001A



SPECIFICATION FOR APPROVAL

REF: 20090406-B

PAGE: 7

PROD. NAME	SMD LINE FILTER	ABC'S DWG NO.	SF3216□□□□L□-□□□
		ABC'S ITEM NO.	

X . UL CARD :

OBMW2 September 8, 2000
 Magnet Wire-Component
 JUNG SHING WIRE CO LTD E174837
 231 CHUNG CHENG RD, SEC 3 JEN-TEH HSIANG, TAINAN
 HSIEN TAIWAN

Mtl Dsg	Mark Dsg	BC	Coat Typ	OC	ANSI Type	Temp Class
AIW	---	Polyamideimide		---	MW81-C	220
CFUEWB	---	Polyurethane		---	MW75C	130
EIAIW	---	Polyesterimide	Polyamideimide	---	MW35C	200
EILOCKY	---	Polyesterimide	Polyamide	---	---	180
EILOCKW	---	Polyesterimide	Modified Epoxy	---	---	200
EIW	---	Polyesterimide		---	---	220
EIW-2	---	Polyesterimide		---	MW74-C	200
FL EILOCKY	---	Modified Polyester	Polyamide	---	---	155
LSFFW	---	Polyurethane		---	MW79-C	155
LSUEW	---	Polyurethane		---	---	130
PEW	---	Polyester		---	---	155
PEY	---	Polyester	Nylon	---	MW24-C	155
SF.FLW	---	Modified Polyester		---	MW26C	155
SF.EIW	---	Polyesterimide		---	MW77C	180
SF.BY@	---	Modified Polyester	Nylon	---	MW27-C	155
SF.FLY@	---	Modified Polyester	Nylon	---	MW27-C	155
SF.BLOCKBS	---	Modified Polyester	Modified Polyamide	---	---	155
SF.EILOCKY#	---	Polyesterimide	Polyamide	---	---	180
SF.EILOCKBS	---	Polyesterimide	Modified Polyamide	---	---	180
SF.BW@	---	Modified Polyester		---	MW26C	155
SFFW	---	Polyurethane		---	MW79	155

287806002

Page 1 of 2

A not-for-profit organization dedicated to public safety and committed to quality service

Mtl Dsg	Mark Dsg	BC	Coat Typ	OC	ANSI Type	Temp Class
SFFY	---	Polyurethane		Polyamide	MW80C	155
UEW-1	---	Polyurethane		---	MW2-C	105
UEW-2	---	Polyurethane		---	---	130
UEW-4	---	Polyurethane		---	MW75C	130
UEY	---	Polyurethane	Nylon	---	MW28-C	130
UEY-2	---	Polyurethane	Polyamide	---	MW28-C	130

@ - May be suffixed by LZ; # - May be suffixed by LZ, EL or LZL.
 LZ - Signifies magnet wires twisted together; EL - signifies base coated magnet wire laid parallel with top coat applied overall; LZL - signifies base coated magnet wire twisted together and covered with top coat overall.

Marking: Company name or trademarks or 榮星電線, material designation or marked designation on packed or reel, and Recognized Component Mark.

See General Information Preceding These Recognitions
 For use only in equipment where the acceptability of the combination is determined by Underwriters Laboratories Inc.

287806002

Page 2 of 2

OBMW2E174837
September 8, 2000