

Final Control Elements

VALVE POSITIONER

Functions & Features

- I/I positioner for proportional valve position control in combination with electric actuator (100 V AC)
- Driving directly AC motor by solid state relay output
- Potentiometer or current feedback selectable
- Timer preventing frequent ON-OFF operation, protecting motor from overheating
- Retransmitted output standard

Typical Applications

- Single phase AC motor
- Loop powered isolator can be used for isolating between setpoint input signal and transmitter output signal

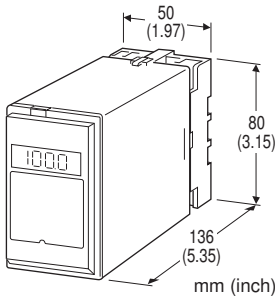

MODEL: MEX-F-[1][2][3][4]1-[5][6]

ORDERING INFORMATION

- Code number: MEX-F-[1][2][3][4]1-[5][6]
- Specify a code from below for each of [1] through [6]. (e.g. MEX-F-11111-B/B/Q)
- Specify the specification for option code /Q (e.g. /C01/S01/SET)

[1] OPERATION MODE SELECTOR

- 1: With
- 0: Without

[2] POSITION SETPOINT INPUT

- 1: 4 - 20 mA DC (Input resistance 100 Ω)
 - 2: 1 - 5 V DC (Input resistance 200 kΩ min.)
 - 3: 4 - 12 mA DC (Input resistance 100 Ω)
 - 4: 12 - 20 mA DC (Input resistance 100 Ω)
- For switching direct/reverse actions with split ranges, select "With" for Operation Mode Selector.

[3] POSITION FEEDBACK INPUT

- 1: Potentiometer
- 2: Current

[4] CONTROL OUTPUT

- 1: SSRs incorporated
- 2: Constant current driving external SSRs
- 3: 24 V AC dry contact

RE-TRANSMITTED OUTPUT

- 1: 4 - 20 mA DC

[5] POWER INPUT

- AC Power**
- B: 100 V AC
 - C: 110 V AC
 - D: 115 V AC
 - F: 120 V AC
 - G: 200 V AC
 - H: 220 V AC
 - J: 240 V AC
- DC Power**
- R: 24 V DC

[6] OPTIONS (multiple selections)

- Brake Function**
- blank: Without
 - /B: With (incorporated SSRs control output type only)
- Signal Indicator**
- blank: Without
 - /E: Front-mounted LCD meter (with operation mode selector type only)
- Other Options**
- blank: none
 - /Q: Option other than the above (specify the specification)

SPECIFICATIONS OF OPTION: Q (multiple selections)

- COATING (For the detail, refer to M-System's web site.)**
- /C01: Silicone coating
 - /C02: Polyurethane coating
 - /C03: Rubber coating
- TERMINAL SCREW MATERIAL**
- /S01: Stainless steel
- EX-FACTORY SETTING**
- /SET: Preset according to the Ordering Information Sheet (No. ESU-4623)

GENERAL SPECIFICATIONS

Construction: Plug-in
Connection: M3.5 screw terminals
Screw terminal: Chromated steel (standard) or stainless steel
Housing material: Flame-resistant resin (black)
Deadband adjustment: 2 - 20 % (front)
Timer adjustment: 1 - 30 sec. (front); 5 sec. minimum with breaking function
Isolation: Setpoint input or xmtr output or feedback input to control output to power (For external SSRs control output, non-isolated between control output and setpoint input etc.)
Zero adjustment (front)
Potentiometer feedback: 0 - 25 %
Current feedback: -10 - +10 %
Span adjustment (front)
Potentiometer feedback: 75 - 100 %
Current feedback: 90 - 110 %
Operation mode: Front-accessed DIP switches; failsafe operation (full-open, full-closed or stop) when there is no position input signal (approx. -12.5 %); direct/reverse re-transmitted output; direct/reverse control action
Electronic limit: Front-accessed potentiometers provided for Operation Mode Selector type

- **Zero limit:** Approx. -10 - +5 %
- **Span limit:** Approx. 95 - 110 %

Breaking function: Dynamic brake (applicable with 100 to 120 V AC motor only)
LCD meter: Indicating re-transmitted output signal; 0.1 % increments

INPUT SPECIFICATIONS

■ **Setpoint Input**
Input resistor: Attached to input terminals (0.5 W)
 ■ **POSITION FEEDBACK INPUT**

- **Current:** 4 - 20 mA DC

Input resistance: 20 Ω
 • **Feedback Potentiometer:** 100 Ω - 10 k Ω
Minimum span: 50 % of total resistance
Excitation: 0.4 V DC

OUTPUT SPECIFICATIONS

■ **Re-Transmitted Output:** 4 - 20 mA DC
Load resistance: 750 Ω max.
 ■ **Control Output**

- **SSR:** Zero-cross function; 80 - 264 V AC @ 0.1 - 1 A

The built-in SSR cannot drive 200 V AC motor (direct/reverse).
Leakage current at OFF: Approx. 10 mA @ 240 V
Remark: When driving relays with this control output, relays may operate erratically due to the leakage current at OFF of

SSR. To avoid the problem, install a resistor (R) in parallel with the relay coil.

$$R < \frac{[\text{Release Voltage}]}{([\text{Leakage Current at OFF}] - [\text{Release Current}])}$$

Output Operation: Refer to the figure at the end of this section.

■ Constant Current

Rating: 10 V DC, 10 mA \pm 10 % at ON;
 0 mA at OFF

Output Operation: Refer to the figure at the end of this section.

• 24 V AC Dry Contact

Drive: Photo MOSFET relay

Rating: 27 V AC/DC @ 1 A

Leakage current at OFF: 1 mA @ 30 V AC

Output Operation: Refer to the figure at the end of this section

• Output Operation (terminal No. in parentheses)

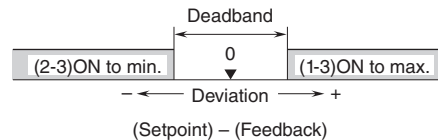

INSTALLATION

Power input

- **AC:** Operational voltage range: rating \pm 10 %, 50/60 \pm 2 Hz, approx. 3 VA
- **DC:** Operational voltage range: 24 V \pm 10 %, approx. 120 mA (ripple 10 %p-p max.)

Operating temperature: -5 to +60°C (23 to 140°F)
Operating humidity: 30 to 90 %RH (non-condensing)
Mounting: Surface or DIN rail
Weight: 300 g (0.66 lb)

PERFORMANCE in percentage of span

Position conversion accuracy: \pm 0.5 %
Re-transmitted output accuracy: \leq 3 % excluding offset and deadband
Insulation resistance: \geq 100 M Ω with 500 V DC
Dielectric strength: 2000 V AC @ 1 minute (setpoint input or xmtr output or feedback input to control output to power to ground)
 (For external SSRs control output, non-isolated between control output and setpoint input etc.)

EXTERNAL VIEW

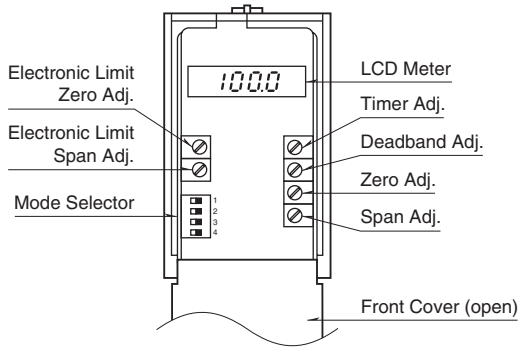

EXTERNAL DIMENSIONS unit: mm (inch)

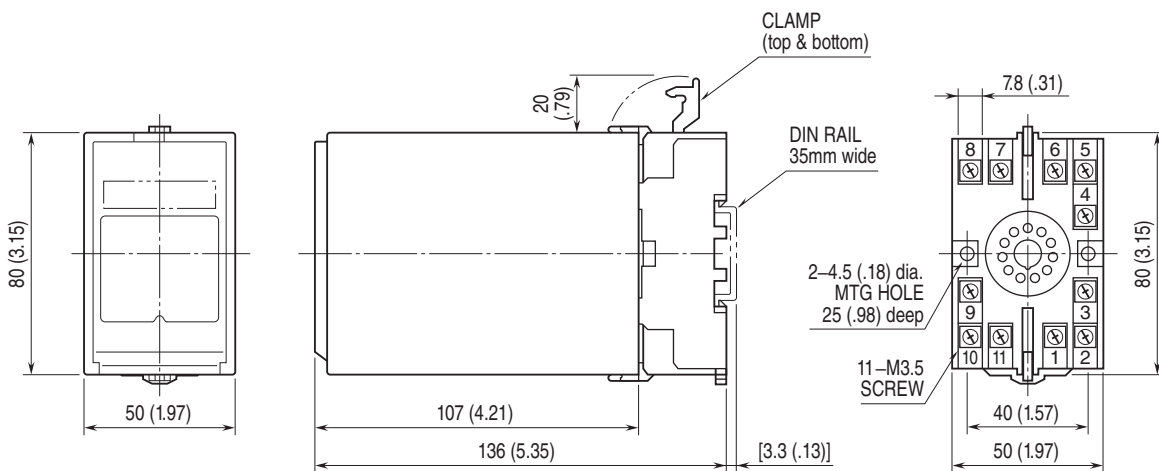

• When mounting, no extra space is needed between units.

TERMINAL ASSIGNMENTS unit: mm (inch)

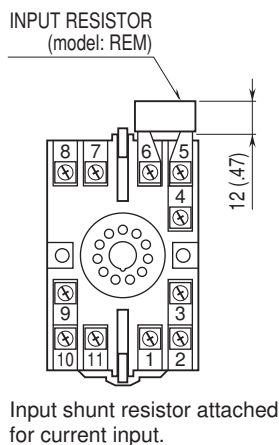

SCHEMATIC CIRCUITRY & CONNECTION DIAGRAM

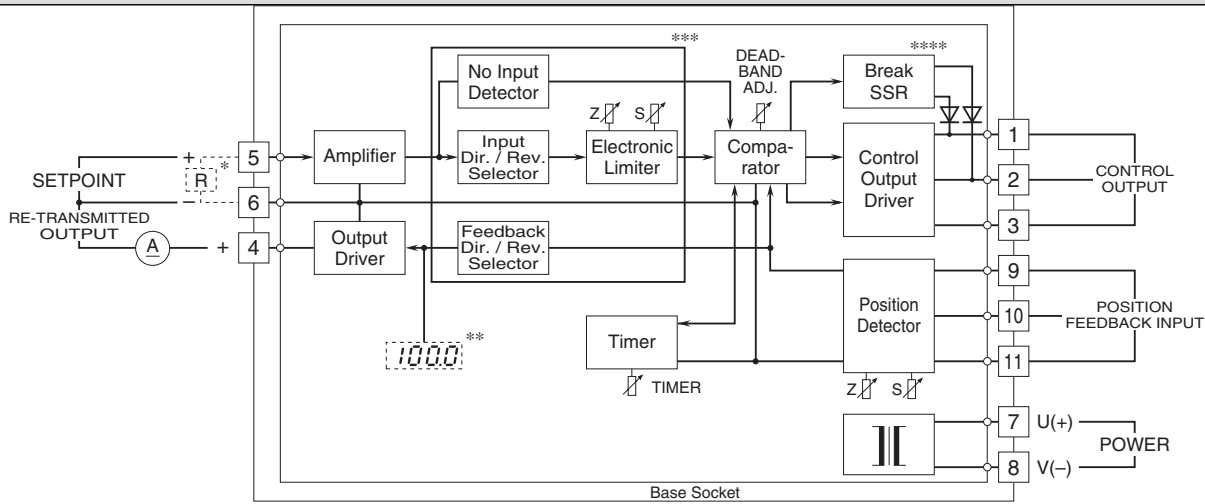

- * Input shunt resistor attached for current input.
- ** Option /E
- *** Operation Mode Selector
- ****Option /B

Control Output Examples

- Incorporated SSR
- 24V AC Dry Contact

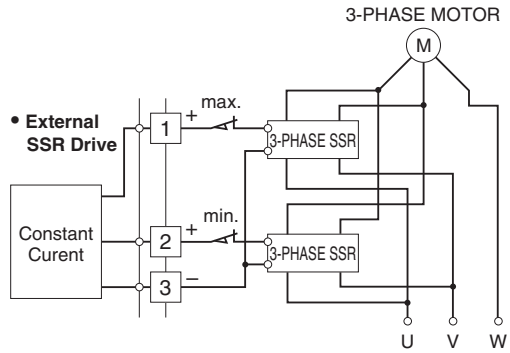
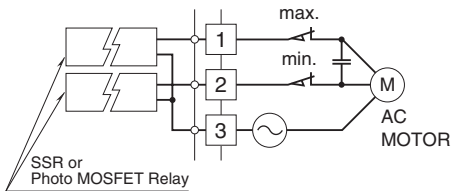

Position Feedback Input Examples

- Potentiometer Feedback

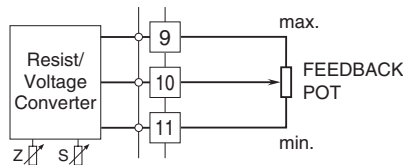

- Current Feedback

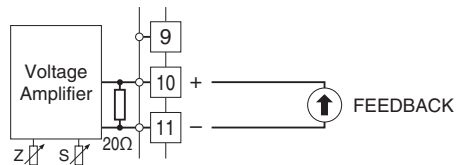

SIGNAL CHARACTERISTICS & DIRECT/REVERSE ACTIONS

• POSITION SETPOINT INPUT & CONTROL OUTPUT

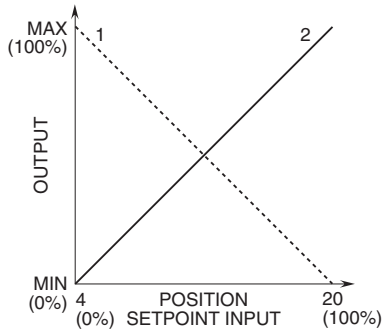

SETTING	GRAPH	OPERATION
Reverse Action	2	When the position setpoint signal increases, the control output goes toward maximum side.
Direct Action	1	When the position setpoint signal increases, the control output goes toward minimum side.

The positioner is factory set to "Reverse" control action. Specify "Operation Mode Selector" type (code 1) when ordering, if changing output action to "Direct".

• RE-TRANSMITTED OUTPUT & CONTROL OUTPUT

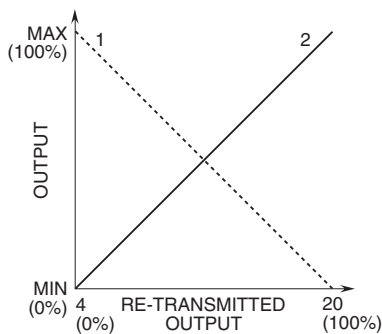

SETTING	GRAPH	OPERATION
Reverse Action	2	When the control output goes toward maximum side, the re-transmitted signal increases.
Direct Action	1	When the control output goes toward maximum side, the re-transmitted signal decreases.

The positioner is factory set to "Reverse" control action. Specify "Operation Mode Selector" type (code 1) when ordering, if changing output action to "Direct".

EXPLANATIONS OF TERMS

• **SSR (Solid State Relay)**

Composed only of semiconductor parts, SSR is free from arc discharge or chattering which is typical with electromagnetic relays. It features excellent characteristics against vibration, physical impact or other environmental conditions.

• **Zero-Cross Function**

SSR with zero-cross function turns on when AC power voltage is near zero, creating delay of switching when input is provided in the middle of an wave cycle, thus limiting transient switching noise voltage and rush current.

• **Photo MOSFET Relay**

A kind of semiconductor relay which has advantages of both solid state relay and mechanical relay, thanks to its low ON-resistance characteristic. It also features high speed ON/OFF operation and low leak current.



Specifications are subject to change without notice.