

# High Speed, Dual Channel, 6A, Power MOSFET Driver With Programmable Delays

## ISL89166, ISL89167, ISL89168

The ISL89166, ISL89167, and ISL89168 are high-speed, 6A, dual channel MOSFET drivers. These parts are similar to the ISL89160, ISL89161, ISL89162 drivers but use the NC pins for programming the rising edge time delays of the outputs used for dead time control.

As an alternative to using external RC circuits for time delays, the programmable delays on the RDTA and RDTB pins allows the user to delay the rising edge of the respective outputs just by connecting an appropriate resistor value between these pins and ground. The accuracy and temperature characteristics of the time delays are specified freeing the user of the need to select appropriate external resistors and capacitors that traditionally are applied to the logic inputs to delay the output edges.

At high switching frequencies, these MOSFET drivers use very little internal bias currents. Separate, non-overlapping drive circuits are used to drive each CMOS output FET to prevent shoot-thru currents in the output stage.

The undervoltage lockout (UV) insures that driver outputs remain off (low) during turn-on until  $V_{DD}$  is sufficiently high for correct logic control. This prevents unexpected glitches when  $V_{DD}$  is being turn-on or turn-off.

## Features

- Dual output, 6A peak current (sink and source)
- Typical ON-resistance  $<1\Omega$
- Specified Miller plateau drive currents
- Very low thermal impedance ( $\theta_{JC} = 3^{\circ}\text{C}/\text{W}$ )
- Hysteretic logic inputs for high noise immunity
- Programmable output rising edge delays using only a resistor.
- ~ 20ns rise and fall time driving a 10nF load.
- Low operating bias currents

## Applications

- Synchronous Rectifier (SR) Driver
- Switch mode power supplies
- Motor Drives, Class D amplifiers, UPS, Inverters
- Pulse Transformer Driver
- Clock/Line Driver

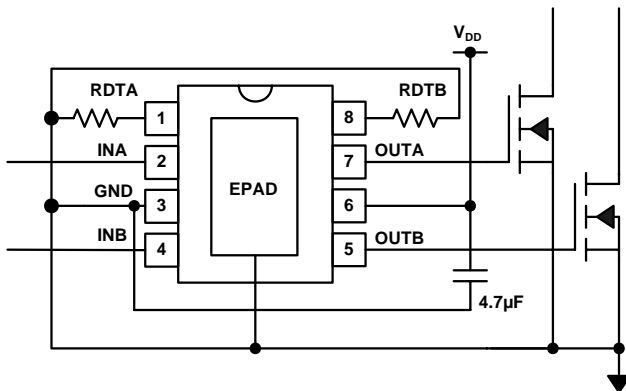

FIGURE 1. TYPICAL APPLICATION

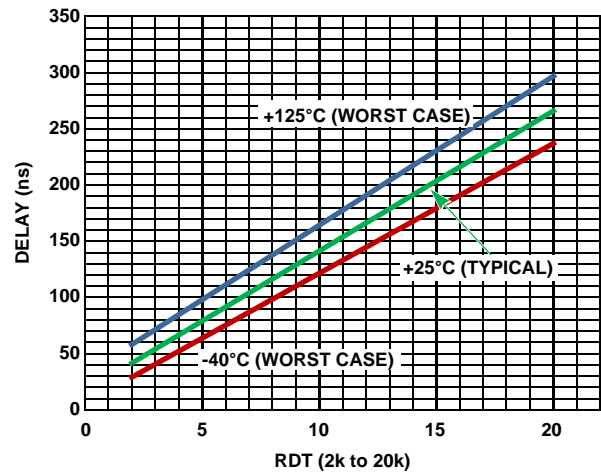
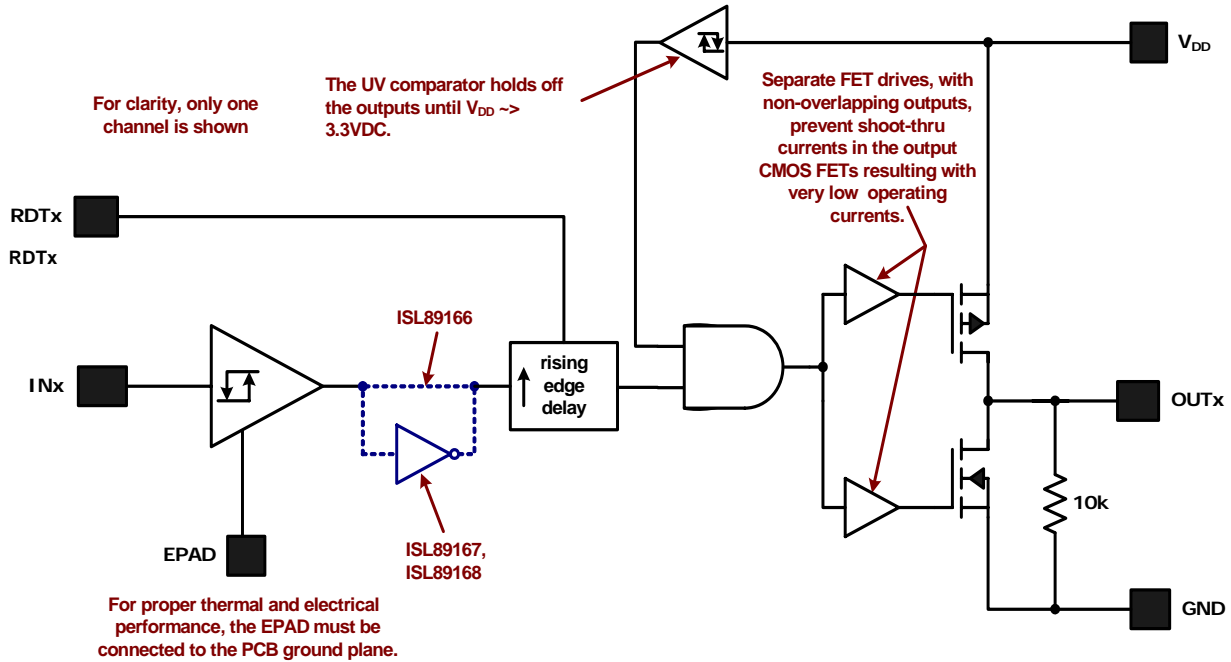

FIGURE 2. PROGRAMMABLE TIME DELAYS

# ISL89166, ISL89167, ISL89168

## Block Diagram



## Pin Configurations

ISL89166FR, ISL89166FB  
(8 LD TDFN, EPSONIC)  
TOP VIEW

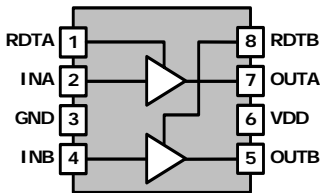

ISL89167FR, ISL89167FB  
(8 LD TDFN, EPSONIC)  
TOP VIEW

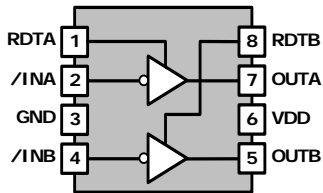

ISL89168FR, ISL89168FB  
(8 LD TDFN, EPSONIC)  
TOP VIEW

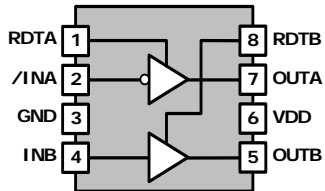

## Pin Descriptions

PIN NUMBER	SYMBOL	DESCRIPTION
1	RDTA	Connect a resistor between this pin and ground to program the rising edge delay of OUTA, 0k to 20k
2	INA or /INA	Channel A input, 0V to VDD
3	GND	Power Ground, 0V
4	INB or /INB	Channel B enable, 0V to VDD
5	OUTB	Channel B output
6	VDD	Power input, 4.5V to 16V
7	OUTA	Channel A output, 0V to VDD
8	RDTB	Connect a resistor between this pin and ground to program the rising edge delay of OUTB, 0k to 20k
	EPAD	Power Ground, 0V

# ISL89166, ISL89167, ISL89168

## Ordering Information

PART NUMBER (Notes 1, 2, 3)	PART MARKING	TEMP RANGE (°C)	INPUT CONFIGURATION	PACKAGE (Pb-Free)	PKG. DWG. #
ISL89166FRTAZ	166A	-40 to +125	non-inverting	8 Ld 3x3 TDFN	L8.3x3I
ISL89167FRTAZ	167A	-40 to +125	inverting	8 Ld 3x3 TDFN	L8.3x3I
ISL89168FRTAZ	168A	-40 to +125	inverting + non-inverting	8 Ld 3x3 TDFN	L8.3x3I
ISL89166FBEAZ	89166 FBEAZ	-40 to +125	non-inverting	8 Ld EPSOIC	M8.15D
ISL89167FBEAZ	89167 FBEAZ	-40 to +125	inverting	8 Ld EPSOIC	M8.15D
ISL89168FBEAZ	89168 FBEAZ	-40 to +125	inverting + non-inverting	8 Ld EPSOIC	M8.15D

### NOTES:

1. Add "-T\*", suffix for tape and reel. Please refer to [TB347](#) for details on reel specifications.
2. These Intersil Pb-free plastic packaged products employ special Pb-free material sets, molding compounds/die attach materials, and 100% matte tin plate plus anneal (e3 termination finish, which is RoHS compliant and compatible with both SnPb and Pb-free soldering operations). Intersil Pb-free products are MSL classified at Pb-free peak reflow temperatures that meet or exceed the Pb-free requirements of IPC/JEDEC J STD-020.
3. For Moisture Sensitivity Level (MSL), please see device information page for [ISL89166](#), [ISL89167](#), [ISL89168](#). For more information on MSL, please see Technical Brief [TB363](#).

# ISL89166, ISL89167, ISL89168

## Absolute Maximum Ratings

Supply Voltage, $V_{DD}$ Relative to GND	-0.3V to 18V
Logic Inputs (INA, INB)	GND - 0.3V to $V_{DD} + 0.3V$
Outputs (OUTA, OUTB)	GND - 0.3V to $V_{DD} + 0.3V$
Average Output Current (Note 6)	150mA

### ESD Ratings

Human Body Model Class 2 (Tested per JESD22-A114E)	2000V
Machine Model Class B (Tested per JESD22-A115-A)	200V
Charged Device Model Class IV	1000V

### Latch-Up

(Tested per JESD-78B; Class 2, Level A)	
Output Current	.500 mA

## Thermal Information

Thermal Resistance (Typical)	$\theta_{JA}$ ( $^{\circ}C/W$ )	$\theta_{JC}$ ( $^{\circ}C/W$ )
8 Ld TDFN Package (Notes 4, 5)	44	3
8 Ld EPSON Package (Notes 4, 5)	42	3
Max Power Dissipation at +25 $^{\circ}C$ in Free Air	2.27W	
Max Power Dissipation at +25 $^{\circ}C$ with Copper Plane	33.3W	
Storage Temperature Range	-65 $^{\circ}C$ to +150 $^{\circ}C$	
Operating Junction Temp Range	-40 $^{\circ}C$ to +125 $^{\circ}C$	
Pb-Free Reflow Profile	see link below	
	<a href="http://www.intersil.com/pbfree/Pb-FreeReflow.asp">http://www.intersil.com/pbfree/Pb-FreeReflow.asp</a>	

## Maximum Recommended Operating Conditions

Junction Temperature	-40 $^{\circ}C$ to +125 $^{\circ}C$
Supply Voltage, $V_{DD}$ Relative to GND	4.5V to 16V
Logic Inputs (INA, INB)	0V to $V_{DD}$
Outputs (OUTA, OUTB)	0V to $V_{DD}$

**CAUTION:** Do not operate at or near the maximum ratings listed for extended periods of time. Exposure to such conditions may adversely impact product reliability and result in failures not covered by warranty

### NOTES:

- $\theta_{JA}$  is measured in free air with the component mounted on a high effective thermal conductivity test board with "direct attach" features. See Tech Brief TB379 for details.
- For  $\theta_{JC}$ , the "case temp" location is the center of the exposed metal pad on the package underside.
- The average output current, when driving a power MOSFET or similar capacitive load, is the average of the rectified output current. The peak output currents of this driver are self limiting by transconductance or  $r_{DS(ON)}$  and do not require any external components to minimize the peaks. If the output is driving a non-capacitive load, such as an LED, maximum output current must be limited by external means to less than the specified absolute maximum.

## DC Electrical Specifications $V_{DD} = 12V$ , $GND = 0V$ , No load on OUTA or OUTB, $R_{DTA} = R_{DTB} = 0k\Omega$ unless otherwise specified. Boldface limits apply over the operating junction temperature range, -40 $^{\circ}C$ to +125 $^{\circ}C$ .

PARAMETERS	SYMBOL	TEST CONDITIONS	$T_J = +25^{\circ}C$			$T_J = -40^{\circ}C$ to +125 $^{\circ}C$		UNITS
			MIN	TYP	MAX	MIN (Note 7)	MAX (Note 7)	
<b>POWER SUPPLY</b>								
Voltage Range	$V_{DD}$		-	-	-	<b>4.5</b>	<b>16</b>	V
$V_{DD}$ Quiescent Current	$I_{DD}$	INx = GND	-	5	-	-	-	mA
		INA = INB = 1MHz, square wave	-	25	-	-	-	mA
<b>UNDERVOLTAGE</b>								
VDD Undervoltage Lock-out (Note 9)	$V_{UV}$	INA = INB = True (Note 10)	-	3.3	-	-	-	V
Hysteresis			-	~25	-	-	-	mV
<b>INPUTS</b>								
Input Range for INA, INB	$V_{IN}$		-	-	-	<b>GND</b>	<b><math>V_{DD}</math></b>	V
Logic 0 Threshold for INA, INB	$V_{IL}$	Nominally 37% x 3.3V	-	1.22	-	<b>1.12</b>	<b>1.32</b>	V
Logic 1 Threshold for INA, INB	$V_{IH}$	Nominally 63% x 3.3V	-	2.08	-	<b>1.98</b>	<b>2.18</b>	V
Input Capacitance of INA, INB (Note 8)	$C_{IN}$		-	2	-	-	-	pF

# ISL89166, ISL89167, ISL89168

**DC Electrical Specifications**  $V_{DD} = 12V$ ,  $GND = 0V$ , No load on OUTA or OUTB,  $R_{DTA} = R_{DTB} = 0k\Omega$  unless otherwise specified. **Boldface limits apply over the operating junction temperature range,  $-40^{\circ}C$  to  $+125^{\circ}C$ .** (Continued)

PARAMETERS	SYMBOL	TEST CONDITIONS	$T_J = +25^{\circ}C$			$T_J = -40^{\circ}C$ to $+125^{\circ}C$		UNITS
			MIN	TYP	MAX	MIN (Note 7)	MAX (Note 7)	
Input Bias Current for INA, INB	$I_{IN}$	$GND < V_{IN} < V_{DD}$	-	-	-	<b>-10</b>	<b>+10</b>	$\mu A$
<b>OUTPUTS</b>								
High Level Output Voltage	$V_{OHA}$ $V_{OHB}$		-	-	-	$V_{DD} - 0.1$	$V_{DD}$	V
Low Level Output Voltage	$V_{OLA}$ $V_{OLB}$		-	-	-	<b>GND</b>	<b>GND + 0.1</b>	V
Peak Output Source Current	$I_O$	$V_O$ (initial) = 0V, $C_{LOAD} = 10nF$	-	-6	-	-	-	A
Peak Output Sink Current	$I_O$	$V_O$ (initial) = 12V, $C_{LOAD} = 10nF$	-	+6	-	-	-	A

**NOTES:**

- Compliance to datasheet limits is assured by one or more methods: production test, characterization and/or design.
- This parameter is taken from the simulation models for the input FET. The actual capacitance on this input will be dominated by the PCB parasitic capacitance.
- A 200 $\mu s$  delay further inhibits the release of the output state when the UV positive going threshold is crossed.
- The true state of a specific part number is defined by the input logic symbol.

**AC Electrical Specifications**  $V_{DD} = 12V$ ,  $GND = 0V$ , No Load on OUTA or OUTB,  $R_{DTA} = R_{DTB} = 0k\Omega$  unless Otherwise Specified. **Boldface limits apply over the operating junction temperature range,  $-40^{\circ}C$  to  $+125^{\circ}C$ .**

PARAMETERS	SYMBOL	TEST CONDITIONS /NOTES	$T_J = +25^{\circ}C$			$T_J = -40^{\circ}C$ to $+125^{\circ}C$		UNITS
			MIN	TYP	MAX	MIN (Note 7)	MAX (Note 7)	
Output Rise Time (see Figure 4)	$t_R$	$C_{LOAD} = 10 nF$ , 10% to 90%	-	20	-	-	<b>40</b>	ns
Output Fall Time (see Figure 4)	$t_F$	$C_{LOAD} = 10 nF$ , 90% to 10%	-	20	-	-	<b>40</b>	ns
Output Rising Edge Propagation Delay (see Figure 3)	$t_{RDLY}$	$R_{DTx} = 0k\Omega$	-	25	-	-	<b>50</b>	ns
Output Falling Edge Propagation Delay (see Figure 3) (Note 12)	$t_{FDLY}$	$R_{DTx} = 0k\Omega$	-	25	-	-	<b>50</b>	ns
Rising Propagation Matching (see Figure 3)	$t_{RM}$	$R_{DTx} = 0k\Omega$	-	<1ns	-	-	-	ns
Falling Propagation Matching (see Figure 3)	$t_{FM}$	$R_{DTx} = 0k\Omega$	-	<1ns	-	-	-	ns
Rising edge timer delay (Note 11)	$t_{RTDLY20}$	$R_{Tx} = 20k\Omega$ , No load	-	266	-	<b>237</b>	<b>297</b>	ns
	$t_{RTDLY2}$	$R_{Tx} = 2.0k\Omega$ , No load	-	42	-	<b>29</b>	<b>58</b>	ns
Miller Plateau Sink Current (See Test Circuit Figure 5)	$-I_{MP}$	$V_{DD} = 10V$ , $V_{MILLER} = 5V$	-	6	-	-	-	A
	$-I_{MP}$	$V_{DD} = 10V$ , $V_{MILLER} = 3V$	-	4.7	-	-	-	A
	$-I_{MP}$	$V_{DD} = 10V$ , $V_{MILLER} = 2V$	-	3.7	-	-	-	A

# ISL89166, ISL89167, ISL89168

**AC Electrical Specifications**  $V_{DD} = 12V$ ,  $GND = 0V$ , No Load on OUTA or OUTB,  $R_{DxA} = R_{DxB} = 0k\Omega$  unless Otherwise Specified. **Boldface limits apply over the operating junction temperature range,  $-40^{\circ}C$  to  $+125^{\circ}C$ .** (Continued)

PARAMETERS	SYMBOL	TEST CONDITIONS /NOTES	$T_J = +25^{\circ}C$			$T_J = -40^{\circ}C$ to $+125^{\circ}C$		UNITS
			MIN	TYP	MAX	MIN (Note 7)	MAX (Note 7)	
Miller Plateau Source Current (See Test Circuit Figure 6)	$I_{MP}$	$V_{DD} = 10V$ , $V_{MILLER} = 5V$	-	5.2	-	-	-	A
	$I_{MP}$	$V_{DD} = 10V$ , $V_{MILLER} = 3V$	-	5.8	-	-	-	A
	$I_{MP}$	$V_{DD} = 10V$ , $V_{MILLER} = 2V$	-	6.9	-	-	-	A

NOTE:

- The rising edge delay timer increases the propagation delay for values of  $R_{DELx} > 2.0k\Omega$ . Time delays for  $R_T < 2.0k\Omega$  and  $R_{Tx} > 20k\Omega$  are not specified and are not recommended. The resistors tolerances (including the boundary values of  $2.0k\Omega$  and  $20.0k\Omega$ ) are recommended to be 1% or better.
- The falling edge propagation delays are independent of the RDT value.

## Test Waveforms and Circuits

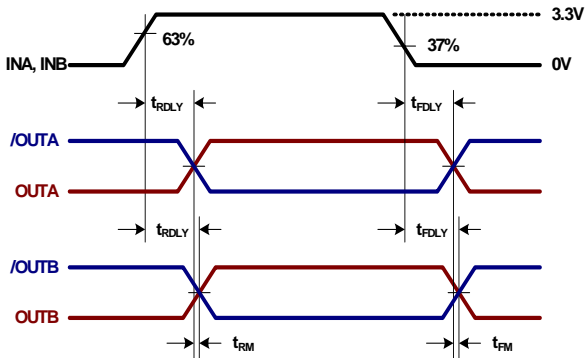

FIGURE 3. PROP DELAYS AND MATCHING

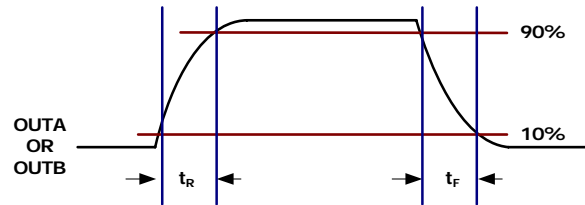

FIGURE 4. RISE/FALL TIMES

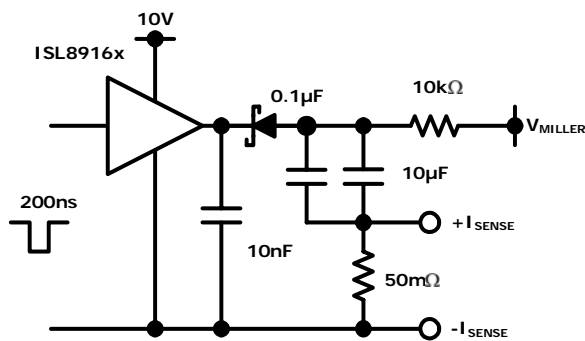

FIGURE 5. MILLER PLATEAU SINK CURRENT TEST CIRCUIT

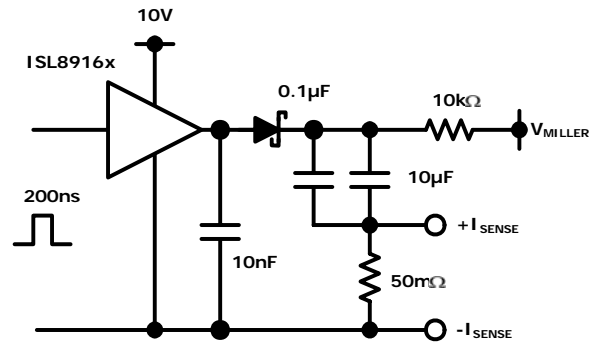

FIGURE 6. MILLER PLATEAU SOURCE CURRENT TEST CIRCUIT

Test Waveforms and Circuits (Continued)

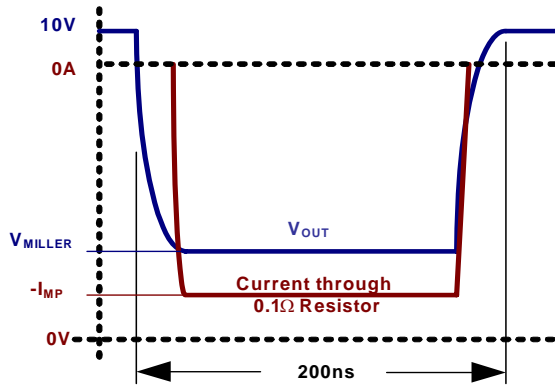

FIGURE 7. MILLER PLATEAU SINK CURRENT

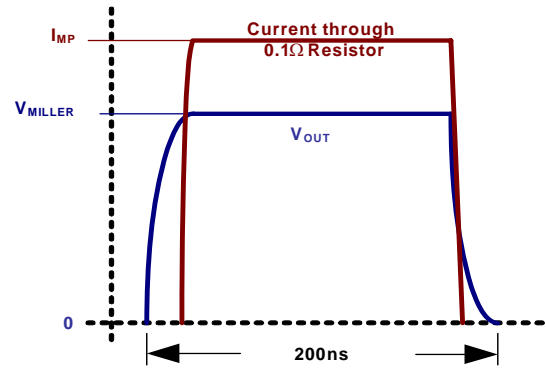

FIGURE 8. MILLER PLATEAU SOURCE CURRENT

Typical Performance Curves

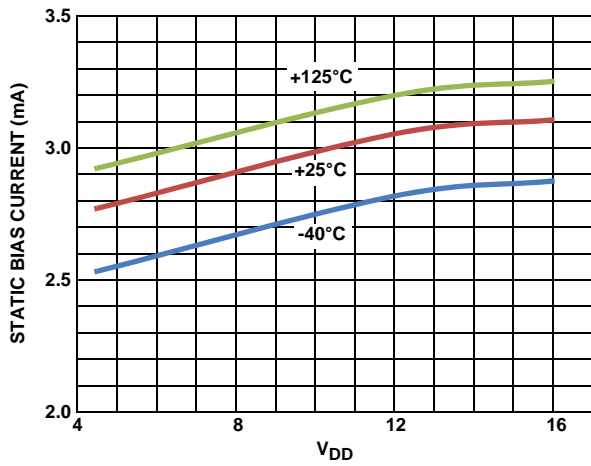

FIGURE 9.  $I_{DD}$  vs  $V_{DD}$  (STATIC)

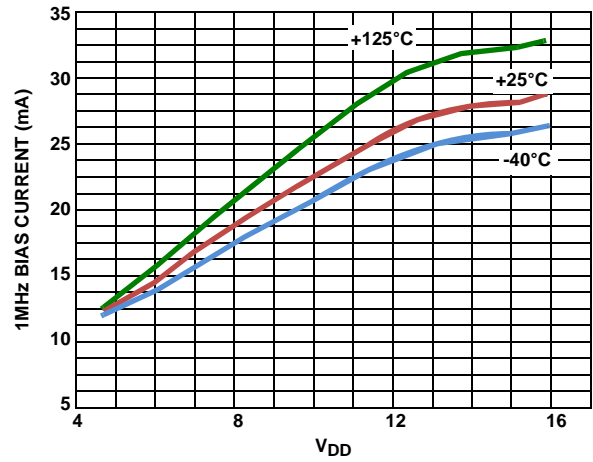

FIGURE 10.  $I_{DD}$  vs  $V_{DD}$  (1 MHz)

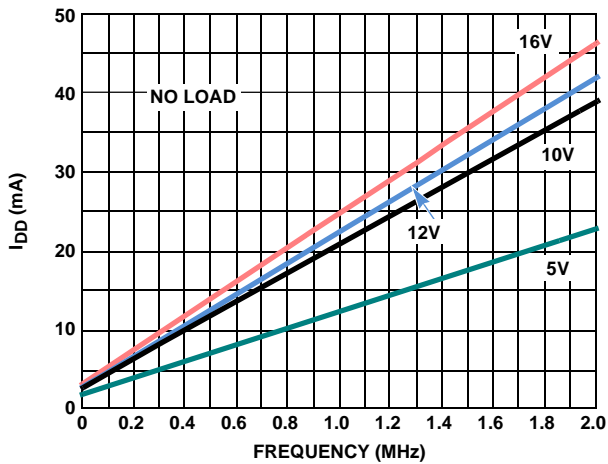

FIGURE 11.  $I_{DD}$  vs FREQUENCY (+25°C)

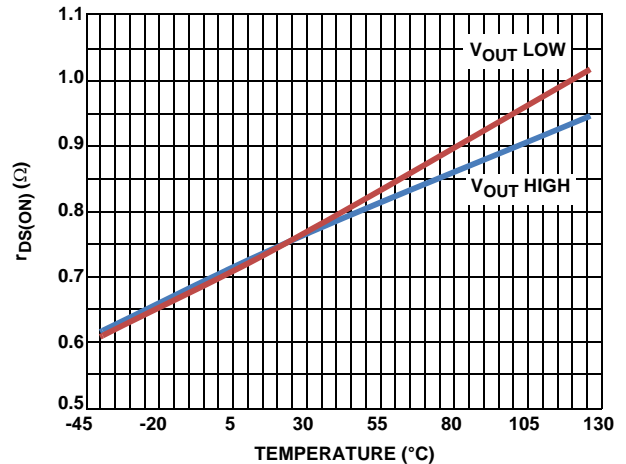

FIGURE 12.  $r_{DS(ON)}$  vs TEMPERATURE

## Typical Performance Curves (Continued)

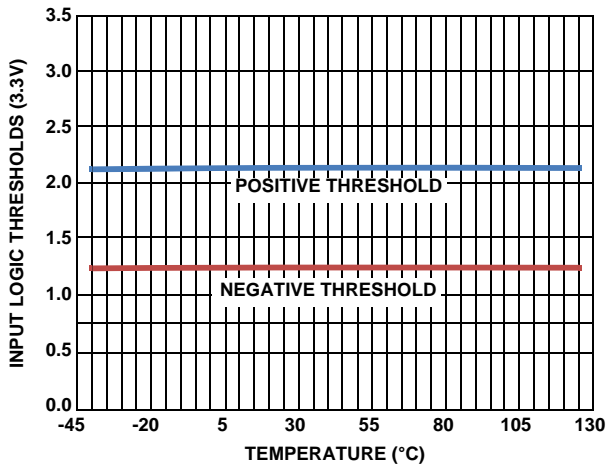

FIGURE 13. INPUT THRESHOLDS

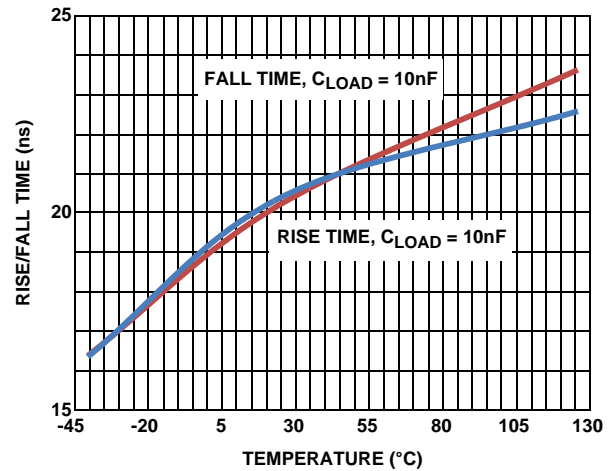

FIGURE 14. OUTPUT RISE/FALL TIME

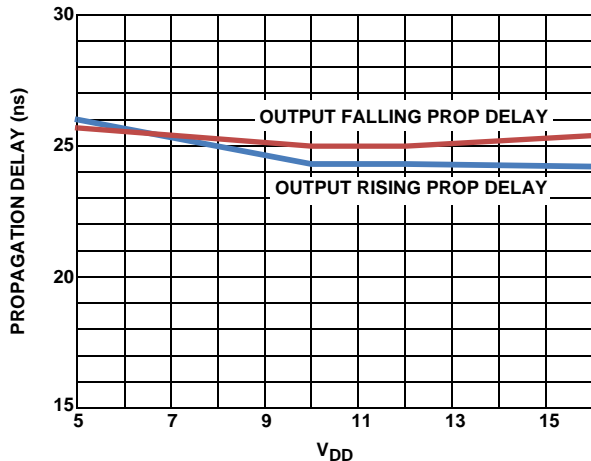

FIGURE 15. PROPAGATION DELAY vs V<sub>DD</sub>

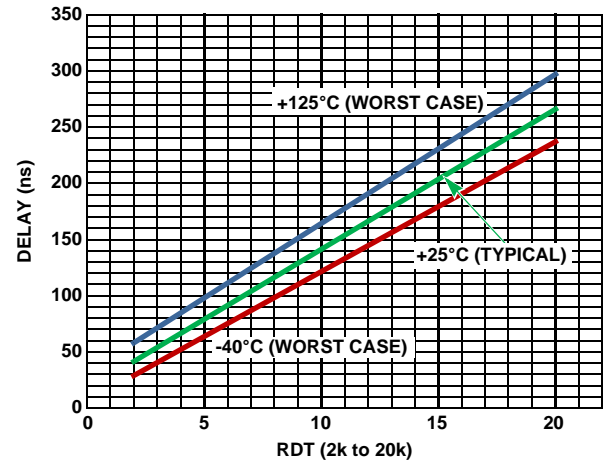

FIGURE 16. PROPAGATION DELAY vs RDT

## Functional Description

### Overview

The ISL89166, ISL89167, ISL89168 drivers incorporate several features including precision input logic thresholds, undervoltage lock-out, fast rising high output drive currents and programmable rising edge output delays.

The programmable delays require only a resistor connector between the RDTA or RDTB pins and ground. This is a useful feature to create dead times for bridge applications to prevent shoot-through or for synchronous rectifier applications to adjust the timing.

To prevent unexpected glitches on the output of the ISL89166, ISL89167, ISL89168 during power-on or power-off when V<sub>DD</sub> is very low, the Undervoltage (UV) lock-out prevents the outputs of the ISL89166, ISL89167, ISL89168 driver from turning on. The UV lock-out forces the driver outputs to be low when V<sub>DD</sub> < ~3.2 VDC regardless of the input logic level.

Fast rising (or falling) output drive current of the ISL89166, ISL89167, ISL89168 minimizes the turn-on (off) delay due to the

input capacitance of the driven FET. The switching transition period at the Miller plateau is also minimized by the high drive currents. (See the specified Miller plateau currents in the AC Electrical Specifications on page 5).

## Application Information

### Programming Rising Edge Delays

As compared to setting the output delays of a driver using a resistor, capacitor and diode on the logic inputs, programming the rising edge output delays of the ISL89166, ISL89167, ISL89168 is almost trivial.

All that is necessary is to select the required resistor value from the Propagation Delay vs RDT graph, Figure 16. Unlike using an RCD network, the operating tolerances over temperature are specified. If a traditional RCD network (Figure 18) is used on the input logic, then it is necessary to account for the tolerance of the logic input threshold, the tolerances of R and C, and their temperature sensitivity.

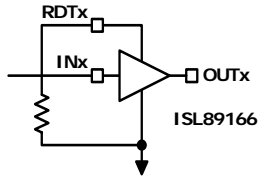

FIGURE 17. SETTING DELAYS A RESISTOR

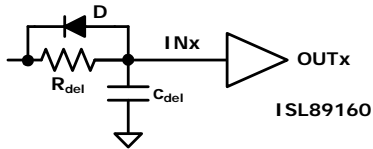

FIGURE 18. SETTING DELAYS WITH A RCD NETWORK

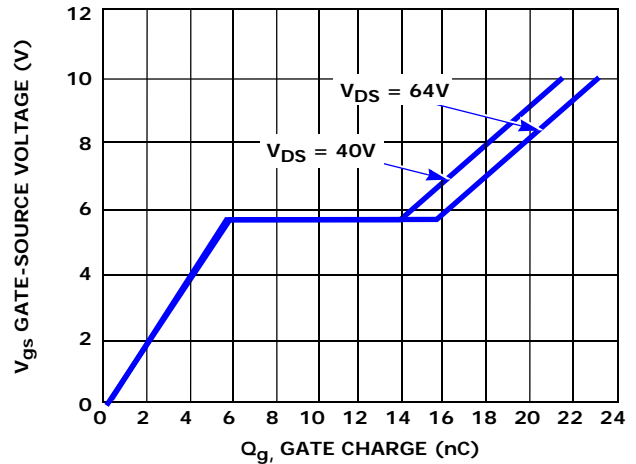

FIGURE 19. MOSFET GATE CHARGE vs GATE VOLTAGE

## Power Dissipation of the Driver

The power dissipation of the ISL89166, ISL89167, ISL89168 is dominated by the losses associated with the gate charge of the driven bridge FETs and the switching frequency. The internal bias current also contributes to the total dissipation but is usually not significant as compared to the gate charge losses.

Figure 19 illustrates how the gate charge varies with the gate voltage in a typical power MOSFET. In this example, the total gate charge for  $V_{GS} = 10V$  is 21.5nC when  $V_{DS} = 40V$ . This is the charge that a driver must source to turn-on the MOSFET and must sink to turn-off the MOSFET.

Equation 1 shows calculating the power dissipation of the driver:

$$P_D = 2 \cdot Q_c \cdot \text{freq} \cdot V_{GS} \cdot \frac{R_{gate}}{R_{gate} + r_{DS(ON)}} + I_{DD}(\text{freq}) \cdot V_{DD} \quad (\text{EQ. 1})$$

Where:

freq = Switching frequency,

$V_{GS} = V_{DD}$  bias of the ISL89166, ISL89167, ISL89168

$Q_c$  = Gate charge for  $V_{GS}$

$I_{DD}(\text{freq})$  = Bias current at the switching frequency (see Figure 9)

$r_{DS(ON)}$  = ON-resistance of the driver

$R_{gate}$  = External gate resistance (if any).

Note that the gate power dissipation is proportionally shared with the external gate resistor. When sizing an external gate resistor, do not overlook the power dissipated by this resistor.

## Typical Application Circuit

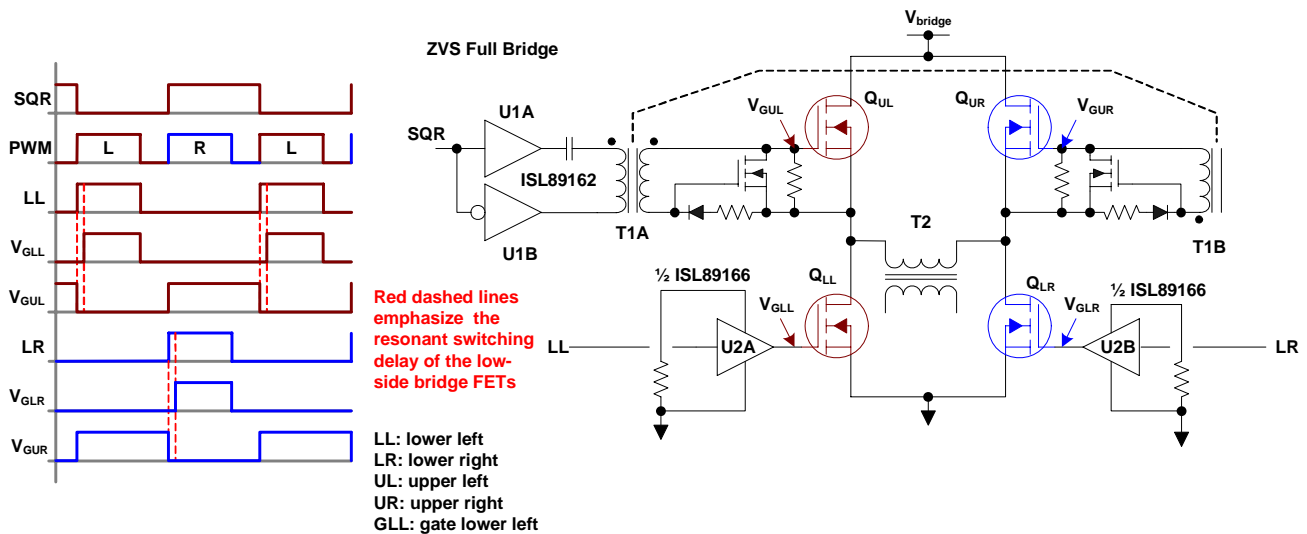

# ISL89166, ISL89167, ISL89168

The Typical Application Circuit is an example of how the ISL89166, ISL89167, ISL89168, MOSFET drivers can be applied in a zero voltage switching full bridge. Two main signals are required: a 50% duty cycle square wave (SQR) and a PWM signal synchronized to the edges of the SQR input. An ISL89162 is used to drive T1 with alternating half cycles driving  $Q_{UL}$  and  $Q_{UR}$ . An ISL89166 is used to drive  $Q_{LL}$  and  $Q_{LR}$  also with alternating half cycles. Unlike the two high side bridge FETs, the two low-side bridge FETs are turned on with a rising edge delay. The delay is setup by resistors connected to RDTA and RDTB pins of the ISL89166. The duration of the delay is chosen to turn on the low-side FETs when the voltage on their respective drains is at the resonant valley.

## General PCB Layout Guidelines

The AC performance of the ISL89166, ISL89167, ISL89168 depends significantly on the design of the PC board. The following layout design guidelines are recommended to achieve optimum performance:

- Place the driver as close as possible to the driven power FET.
- Understand where the switching power currents flow. The high amplitude  $di/dt$  currents of the driven power FET will induce significant voltage transients on the associated traces.
- Keep power loops as short as possible by paralleling the source and return traces.
- Use planes where practical; they are usually more effective than parallel traces.
- Avoid paralleling high amplitude  $di/dt$  traces with low level signal lines. High  $di/dt$  will induce currents and consequently, noise voltages in the low level signal lines.
- When practical, minimize impedances in low level signal circuits. The noise, magnetically induced on a 10k resistor, is 10x larger than the noise on a 1k resistor.
- Be aware of magnetic fields emanating from transformers and inductors. Gaps in these structures are especially bad for emitting flux.
- If you must have traces close to magnetic devices, align the traces so that they are parallel to the flux lines to minimize coupling.
- The use of low inductance components such as chip resistors and chip capacitors is highly recommended.
- Use decoupling capacitors to reduce the influence of parasitic inductance in the VDD and GND leads. To be effective, these caps must also have the shortest possible conduction paths. If vias are used, connect several paralleled vias to reduce the inductance of the vias.
- It may be necessary to add resistance to dampen resonating parasitic circuits especially on OUTA and OUTB. If an external gate resistor is unacceptable, then the layout must be improved to minimize lead inductance.
- Keep high  $dv/dt$  nodes away from low level circuits. Guard banding can be used to shunt away  $dv/dt$  injected currents from sensitive circuits. This is especially true for control circuits

that source the input signals to the ISL89166, ISL89167, ISL89168.

- Avoid having a signal ground plane under a high amplitude  $dv/dt$  circuit. This will inject  $di/dt$  currents into the signal ground paths.
- Do power dissipation and voltage drop calculations of the power traces. Many PCB/CAD programs have built in tools for calculation of trace resistance.
- Large power components (Power FETs, Electrolytic caps, power resistors, etc.) will have internal parasitic inductance which cannot be eliminated. This must be accounted for in the PCB layout and circuit design.
- If you simulate your circuits, consider including parasitic components especially parasitic inductance.

## General EPAD Heatsinking Considerations

The thermal pad is electrically connected to the GND supply through the IC substrate. The epad of the ISL89166, ISL89167, ISL89168 has two main functions: to provide a quiet GND for the input threshold comparators and to provide heat sinking for the IC. The EPAD must be connected to a ground plane and no switching currents from the driven FET should pass through the ground plane under the IC.

Figure 20 is a PCB layout example of how to use vias to remove heat from the IC through the epad.

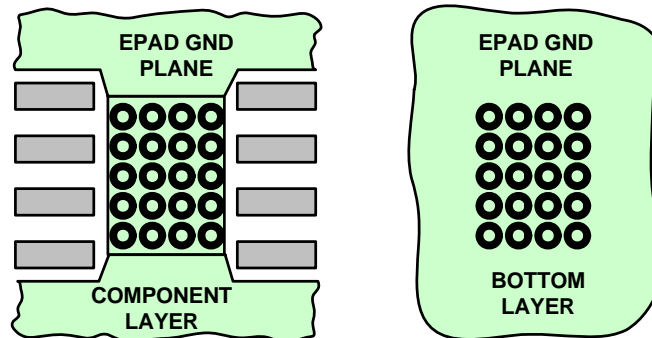

FIGURE 20. TYPICAL PCB PATTERN FOR THERMAL VIAS

For maximum heatsinking, it is recommended that a ground plane, connected to the EPAD, be added to both sides of the PCB. A via array, within the area of the EPAD, will conduct heat from the EPAD to the gnd plane on the bottom layer. The number of vias and the size of the GND planes required for adequate heatsinking is determined by the power dissipated by the ISL89166, ISL89167, ISL89168, the air flow and the maximum temperature of the air around the IC.

## Revision History

The revision history provided is for informational purposes only and is believed to be accurate, but not warranted. Please go to web to make sure you have the latest Rev.

DATE	REVISION	CHANGE
1/14/11	FN7720.0	Initial Release

---

## Products

Intersil Corporation is a leader in the design and manufacture of high-performance analog semiconductors. The Company's products address some of the industry's fastest growing markets, such as, flat panel displays, cell phones, handheld products, and notebooks. Intersil's product families address power management and analog signal processing functions. Go to [www.intersil.com/products](http://www.intersil.com/products) for a complete list of Intersil product families.

\*For a complete listing of Applications, Related Documentation and Related Parts, please see the respective device information page on intersil.com: [ISL89166](#), [ISL89167](#), [ISL89168](#).

To report errors or suggestions for this datasheet, please go to [www.intersil.com/askourstaff](http://www.intersil.com/askourstaff)

FITs are available from our website at <http://rel.intersil.com/reports/sear>

# ISL89166, ISL89167, ISL89168

## Package Outline Drawing L8.3x3I

8 LEAD THIN DUAL FLAT NO-LEAD PLASTIC PACKAGE

Rev 1 6/09

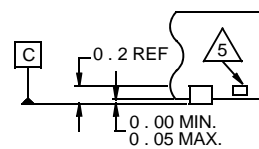
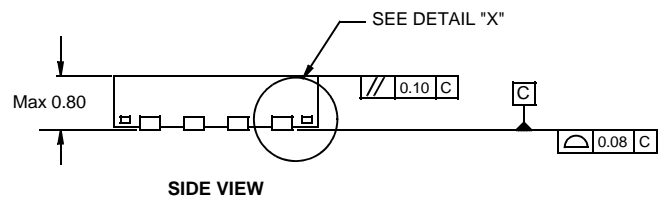
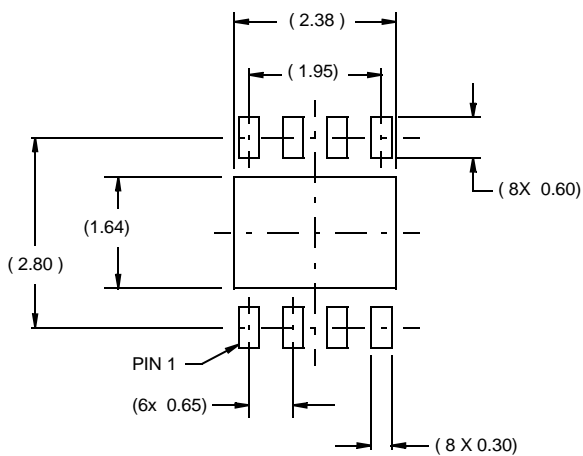
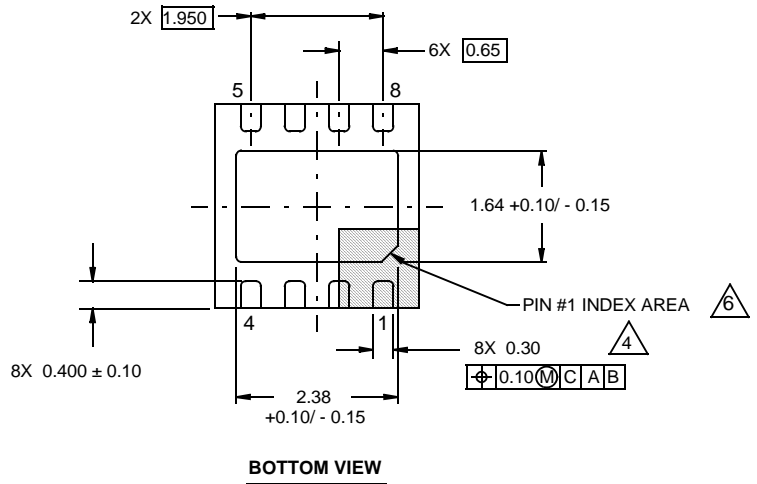
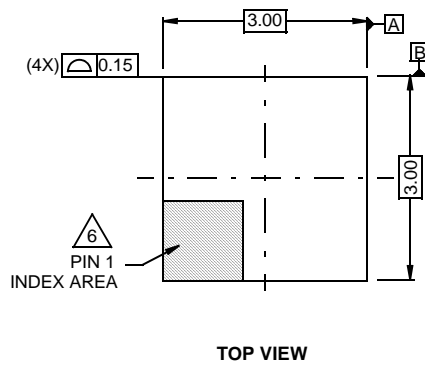

### NOTES:

- Dimensions are in millimeters.  
Dimensions in ( ) for Reference Only.
- Dimensioning and tolerancing conform to AMSE Y14.5m-1994.
- Unless otherwise specified, tolerance : Decimal  $\pm 0.05$
- Dimension applies to the metallized terminal and is measured between 0.15mm and 0.30mm from the terminal tip.
- Tiebar shown (if present) is a non-functional feature.
- The configuration of the pin #1 identifier is optional, but must be located within the zone indicated. The pin #1 identifier may be either a mold or mark feature.

# ISL89166, ISL89167, ISL89168

## Small Outline Exposed Pad Plastic Packages (EPSONIC)

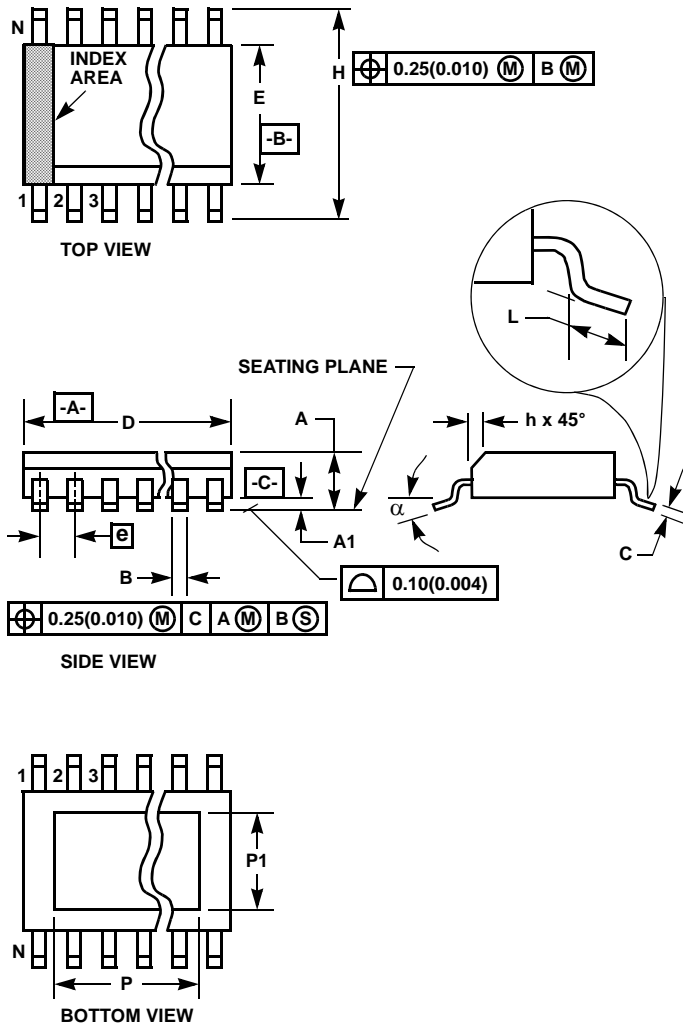

### M8.15D 8 LEAD NARROW BODY SMALL OUTLINE EXPOSED PAD PLASTIC PACKAGE

SYMBOL	INCHES		MILLIMETERS		NOTES
	MIN	MAX	MIN	MAX	
A	0.059	0.067	1.52	1.72	-
A1	0.003	0.009	0.10	0.25	-
B	0.0138	0.0192	0.36	0.46	9
C	0.0075	0.0098	0.19	0.25	-
D	0.189	0.196	4.80	4.98	3
E	0.150	0.157	3.811	3.99	4
e	0.050 BSC		1.27 BSC		-
H	0.230	0.244	5.84	6.20	-
h	0.010	0.019	0.25	0.50	5
L	0.016	0.050	0.41	1.27	6
N	8		8		7
$\alpha$	0°	8°	0°	8°	-
P	0.118	0.137	3.00	3.50	11
P1	0.078	0.099	2.00	2.50	11

Rev. 0 5/07

#### NOTES:

1. Symbols are defined in the "MO Series Symbol List" in Section 2.2 of Publication Number 95.
2. Dimensioning and tolerancing per ANSI Y14.5M-1982.
3. Dimension "D" does not include mold flash, protrusions or gate burrs. Mold flash, protrusion and gate burrs shall not exceed 0.15mm (0.006 inch) per side.
4. Dimension "E" does not include interlead flash or protrusions. Interlead flash and protrusions shall not exceed 0.25mm (0.010 inch) per side.
5. The chamfer on the body is optional. If it is not present, a visual index feature must be located within the crosshatched area.
6. "L" is the length of terminal for soldering to a substrate.
7. "N" is the number of terminal positions.
8. Terminal numbers are shown for reference only.
9. The lead width "B", as measured 0.36mm (0.014 inch) or greater above the seating plane, shall not exceed a maximum value of 0.61mm (0.024 inch).
10. Controlling dimension: MILLIMETER. Converted inch dimensions are not necessarily exact.
11. Dimensions "P" and "P1" are thermal and/or electrical enhanced variations. Values shown are maximum size of exposed pad within lead count and body size.

For additional products, see [www.intersil.com/product\\_tree](http://www.intersil.com/product_tree)

Intersil products are manufactured, assembled and tested utilizing ISO9000 quality systems as noted in the quality certifications found at [www.intersil.com/design/quality](http://www.intersil.com/design/quality)

Intersil products are sold by description only. Intersil Corporation reserves the right to make changes in circuit design, software and/or specifications at any time without notice. Accordingly, the reader is cautioned to verify that data sheets are current before placing orders. Information furnished by Intersil is believed to be accurate and reliable. However, no responsibility is assumed by Intersil or its subsidiaries for its use; nor for any infringements of patents or other rights of third parties which may result from its use. No license is granted by implication or otherwise under any patent or patent rights of Intersil or its subsidiaries.

For information regarding Intersil Corporation and its products, see [www.intersil.com](http://www.intersil.com)