

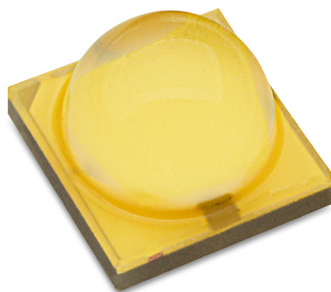

LUXEON V

Unmatched flux density with the lowest thermal resistance enabling never before possible form factors



LUXEON V is a Chip Scale Package (CSP) based high power emitter designed to deliver maximum flux in a compact 4.0mm x 4.0mm footprint. LUXEON V offers a unique combination of high efficacy at high drive current with extremely low thermal resistance and optimized radiation pattern to support next generation fixture designs. Building on the strengths of Lumileds Patterned Sapphire Substrate (PSS) CSP technology, LUXEON V offers the highest drive current capability in its class.

FEATURES AND BENEFITS

- Over 1700 lumens from a single, compact source
- Low thermal resistance of 0.8 K/W enables more efficient thermal management—smaller heatsink, more compact fixtures
- High efficacy at high drive current provides design flexibility and supports high flux density fixtures
- Optimized radiation pattern delivers high intensity beams from smaller optics
- Uniform optical source supports directional applications and imaging optics

PRIMARY APPLICATIONS

- High Bay & Low Bay
- Outdoor
 - Stadium and Area Lighting
- Specialty
 - Torch
 - Other Portables
- Spotlights

LUXEON V product performance at 1400mA, $T_j=85^\circ\text{C}$.

| NOMINAL CCT | CRI ^[1, 2] | LUMINOUS FLUX ^[1] (lm) | | PART NUMBER ^[3] |
|-------------|-----------------------|-----------------------------------|---------|----------------------------|
| | | MINIMUM | TYPICAL | |
| 3000K | 70 minimum | 480 | 545 | L1V1-307003Vx00000 |
| 4000K | 70 minimum | 510 | 576 | L1V1-407003Vx00000 |
| 5000K | 70 minimum | 510 | 580 | L1V1-507003Vx00000 |
| 5700K | 70 minimum | 510 | 580 | L1V1-577003Vx00000 |
| 6500K | 70 minimum | 510 | 580 | L1V1-657003Vx00000 |
| 5700K | 70 typical | 510 | 580 | L1V1-577T03Vx00000 |
| 6500K | 70 typical | 510 | 580 | L1V1-657T03Vx00000 |

Notes:

1. Lumileds maintains a tolerance of ± 2 on CRI and $\pm 6.5\%$ on luminous flux measurements.
2. Typical CRI is approximately 2 points higher for those parts with minimum 70CRI specified, but this is not guaranteed. Minimum CRI is 68.5 for parts with 70CRI typical.
3. x = 5 or 7 and defines the number of MacAdam ellipse steps.

Mechanical Dimensions.

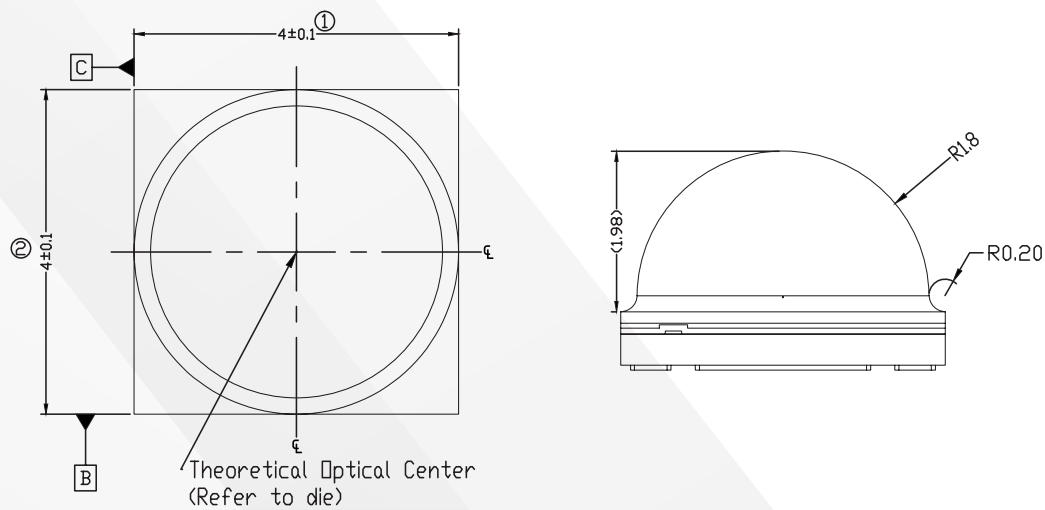

Notes:

1. Drawings are not to scale.
2. All dimensions are in millimeters.