



USR5VA10

Preliminary

CMOS IC

SYNCHRONOUS RECTIFIER

DESCRIPTION

UTC **USR5VA10** is a synchronous rectifying IC with 20mΩ/45V NMOS and synchronous rectification control IC integrated. It is suitable for flyback switch mode power supply of up to 5V/2A. Efficiency increased by 2%~5% and temperature decreased by up to 50% compared with normal Schottky Barrier Diode, or more than 2% efficiency increase and 20% temperature decrease compared with low VF diode.

FEATURES

- * High efficiency, Low temperature
- * Synchronous rectification, support DCM and QR mode flyback system
- * Internal integrated 20mΩ/45V NMOS
- * Self-power supply design, no need for external power supply
- * Self-detection, no need for external synchronous signal
- * Only 3 poles (V_{CC} -K-A), can directly replace Schottky Barrier Diode

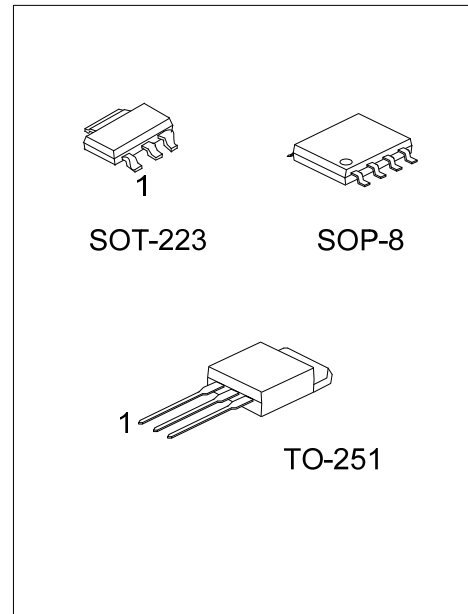

ORDERING INFORMATION

Ordering Number		Package	Pin Assignment								Packing	
Lead Free	Halogen Free		1	2	3	4	5	6	7	8		
USR5VA10L-AA3-R	USR5VA10G-AA3-R	SOT-223	V_{CC}	K	A	-	-	-	-	-	-	Tape Reel
USR5VA10L-TM3-T	USR5VA10G-TM3-T	TO-251	V_{CC}	K	A	-	-	-	-	-	-	Tube
USR5VA10L-S08-R	USR5VA10G-S08-R	SOP-8	A	A	A	V_{CC}	K	K	K	K	K	Tape Reel

<p>USR5VA10G-AA3-R</p> <p>(1)Packing Type</p> <p>(2)Package Type</p> <p>(3)Green Package</p>	<p>(1) R: Tape Reel, T: Tube</p> <p>(2) AA3: SOT-223, TM3: TO-251, S08: SOP-8</p> <p>(3) G: Halogen Free and Lead Free, L: Lead Free</p>
--	--

MARKING

PACKAGE	MARKING
SOT-223	<p>1</p> <p>L: Lead Free G: Halogen Free Date Code</p>
TO-251	<p>1</p> <p>L: Lead Free G: Halogen Free Date Code</p> <p>Lot Code</p>
SOP-8	<p>Date Code</p> <p>L: Lead Free G: Halogen Free</p> <p>Lot Code</p>

PIN DESCRIPTION

PIN NO.	PIN NAME	DESCRIPTION
1	V _{CC}	Inside power supply, bypass a capacitor between V _{CC} and A
2	K	Same as negative pole of Diode
3	A	Same as positive pole of Diode

BLOCK DIAGRAM

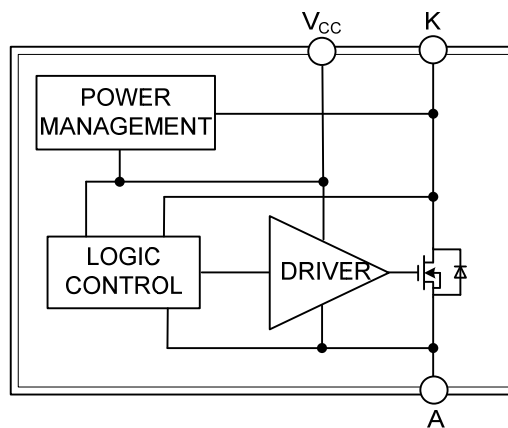

■ ABSOLUTE MAXIMUM RATING

PARAMETER	SYMBOL	RATINGS	UNIT
P, N Reverse Voltage	V_{PN}	45	V
Operating Temperature	T_A	-25 ~ +120	°C
Storage Temperature	T_{STG}	-55 ~ +155	°C

Note: Absolute maximum ratings are those values beyond which the device could be permanently damaged. Absolute maximum ratings are stress ratings only and functional device operation is not implied.

■ ELECTRICAL CHARACTERISTICS ($T_A=25^\circ\text{C}$, unless otherwise specified)

PARAMETER	SYMBOL	TEST CONDITIONS	MIN	TYP	MAX	UNIT
V_{CC} Operation Voltage	V_{CC}		7	11	15	V
V_{CC} Start-up Voltage	V_{CC_ON}		4	5	6	V
V_{CC} UVLO	V_{CC_UVLO}		3	4	5	V
Quiescent Current	I_{CC}	$V_{CC}=11\text{V}$	80	150	260	μA
Gate Turn On Threshold	V_{THON}	N point tested first	-230		-50	mV
Gate Turn Off Threshold	V_{THOFF}		-35	-6	-1	mV
Turn On Delay Time	T_{DON}	From V_{THON} to GATE>2V			200	ns
Turn Off Delay Time	T_{DOFF}	From V_{THOFF} to GATE<9V			50	ns
Internal MOS R_{DSON}	R_{DSON}		15		20	m Ω
Maximum Peak Current	I_{PEAK}	$T_A=25^\circ\text{C}$			60	A
SW to GND Breakdown Voltage	$V_{(BR)DSS}$		40	45	50	V

■ DETAILED DESCRIPTION**Self-Power Supply Circuit**

There is self-power supply circuit with inside the IC, which can drive the IC and MOS without external power supply.

Start Up

With K pole voltage is higher than A pole, self-power supply circuit will support the power of V_{CC} , V_{CC} voltage increases. If V_{CC} voltage is lower than start up voltage V_{CC_ON} , internal Power MOS is off. When V_{CC} voltage is higher than V_{CC_ON} , startup mode is finished. When V_{CC} voltage is lower than V_{CC_UVLO} , IC returns to startup mode.

Power MOS Control

If the detected voltage of (K-A) lower than V_{on} , Power MOS will be open. If the detected voltage of (K-A) is higher than V_{THOFF} , Power MOS will be closed.

RC Absorbing Circuit

In status of starting up, output short circuit, over input voltage and CCM modes, there will be peak voltage, as to avoid the breaking of MOS, can add RC absorbing circuit between A and K, so that the peak voltage on N can be reduced.

On-Resistance

During operation, internal resistance increases together with the temperature, efficiency decreases accordingly. It is better to enlarge the heat releasing area so that the IC temperature can be decreased.

■ TYPICAL APPLICATION CIRCUIT

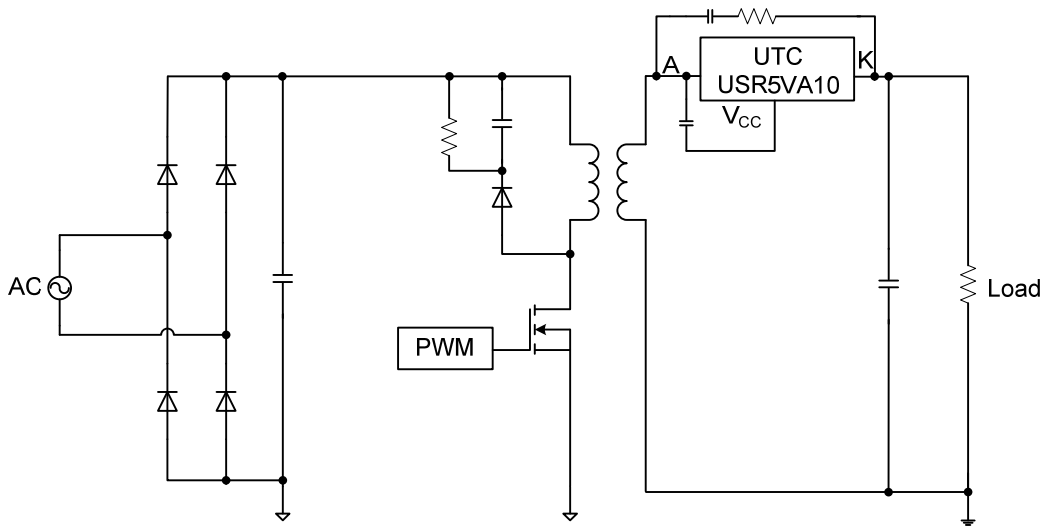

Figure 1. Forward Rectification Application Circuit

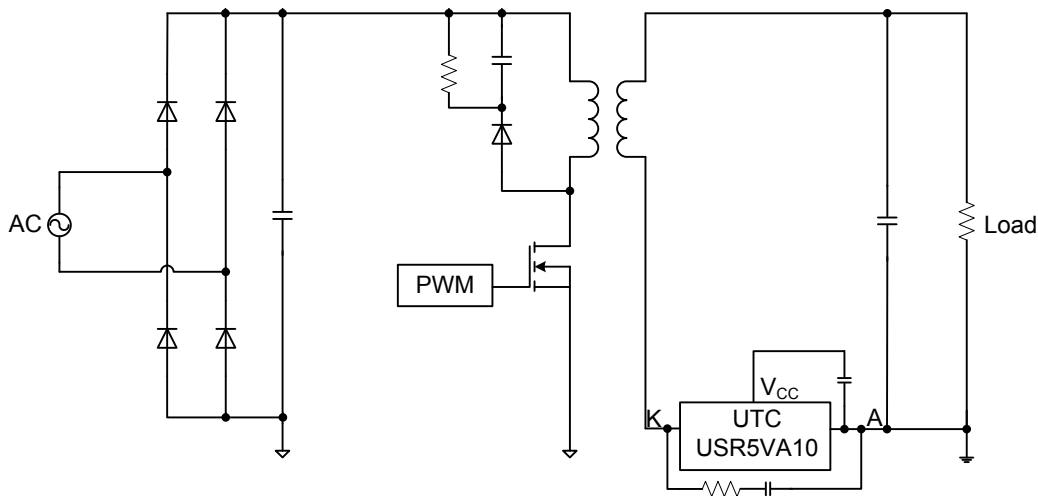

Figure 2. Reverse Rectification Application Circuit

UTC assumes no responsibility for equipment failures that result from using products at values that exceed, even momentarily, rated values (such as maximum ratings, operating condition ranges, or other parameters) listed in products specifications of any and all UTC products described or contained herein. UTC products are not designed for use in life support appliances, devices or systems where malfunction of these products can be reasonably expected to result in personal injury. Reproduction in whole or in part is prohibited without the prior written consent of the copyright owner. UTC reserves the right to make changes to information published in this document, including without limitation specifications and product descriptions, at any time and without notice. This document supersedes and replaces all information supplied prior to the publication hereof.