

Surface Mount Auto Surge Suppressor

Working Peak Reverse Voltage - 30 to 42 Volts

10000 Watt Peak Pulse Power

Features

- Glass passivated chip
- 10000 W peak pulse power capability with a 10/1000μs waveform, repetitive rate (duty cycle): 0.01 %
- Meet AEC-Q101 requirement
- Low leakage
- Uni-directional polarity
- Excellent clamping capability
- Very fast response time
- RoHS compliant



Mechanical Data

- Plastic package DO-218AB/SOD-BLOCK
- Epoxy: UL 94V-0 rate flame retardant
- Polarity: Heatsink is anode

Maximum Ratings (TA=25°C unless otherwise noted)

RATING	SYMBOL	VALUE	UNITS
Peak power dissipation with a 10/1000μs waveform (Note 1)	P _{PP}	10000	Watts
Peak pulse current with a 10/1000μs waveform (Note 1)	I _{PP}	SEE TABLE 1	Amps
Power dissipation on infinite heatsink at TL = 25°C	P _D	8.0	Watts
Peak Forward Surge Current, 8.3ms Single Half Sine-Wave	I _{FSM}	700	Amps
Operating junction and storage temperature range	T _J , T _{STG}	-55 to +175	°C

Notes :

1. Non-repetitive current pulse, per Fig. 2 and derated above TA = 25°C per Fig. 1.

Dimensions (DO-218AB)

DO-218AB

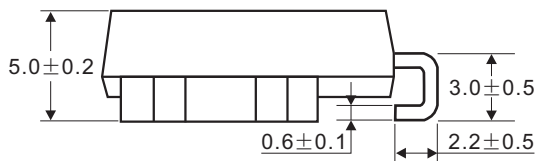
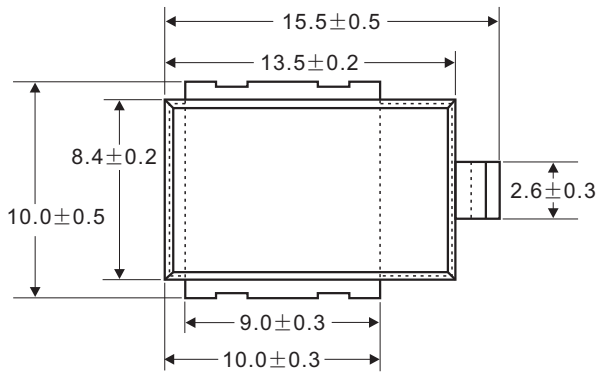

Dimensions in millimeters

Recommended Mounting Pad Layout

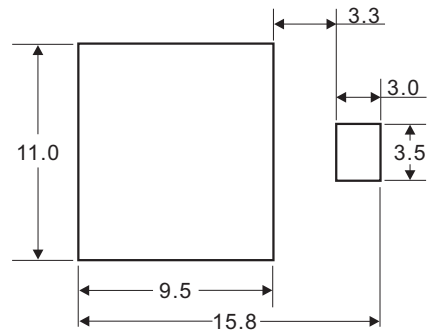

Dimensions in millimeters

Electrical Characteristics

TABLE 1

***Stand for commonly used models

ASC Part Number	Working Peak Reverse Voltage	Breakdown Voltage $V_{BR}@I_T$			Max. Reverse Leakage I_R @ V_{RWM}	Max. I_R @ V_{RWM} $T_J=175$	Max. Clamping Voltage V_c @ $I_{pp} 10/1000\mu s$	
	$V_{RWM}(V)$	$V_{BR}(V)Min.$	$V_{BR}(V)Max.$	$I_T(mA)$	$I_R(\mu A)$	$I_R(\mu A)$	$V_c(V)$	$I_{pp}(A)$
ASC30A	30	33.3	36.8	5	10	150	48.4	206.6
ASC33A	33	36.7	40.6	5	10	150	53.3	187.6
* ASC36A	36	40.0	44.2	5	10	150	58.1	172.1
ASC42A	42	46.8	52.0	5	10	150	68.4	146.2

IEC Compatibility

ISO16750 -2 Test A Test Waveform

ASC Part Number	12V system	24V system	Resistance				
	100V@400ms	202V@350ms	0.5Ω	1Ω	2Ω	4Ω	8Ω
ASC30A	-	√	-	X	?	√	√
ASC33A	-	√	-	X	?	√	√
ASC36A	-	√	-	X	?	√	√
ASC42A	-	√	-	X	?	√	√

Notes :

- ? :The test results would be different depending on the specific circuit parameters or test environment
- x :Failed

Ratings and Characteristic Curves (TA=25 °C unless otherwise noted)

Fig.1 Power Derating Curve

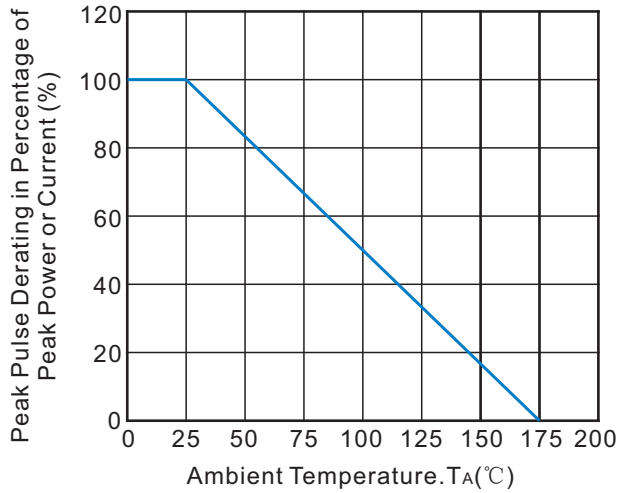

Fig.2 Pulse Waveform

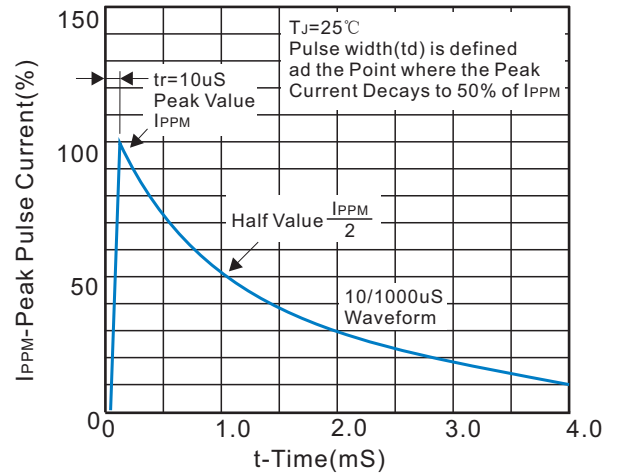

Fig.3 Steady State Power Derating Curve

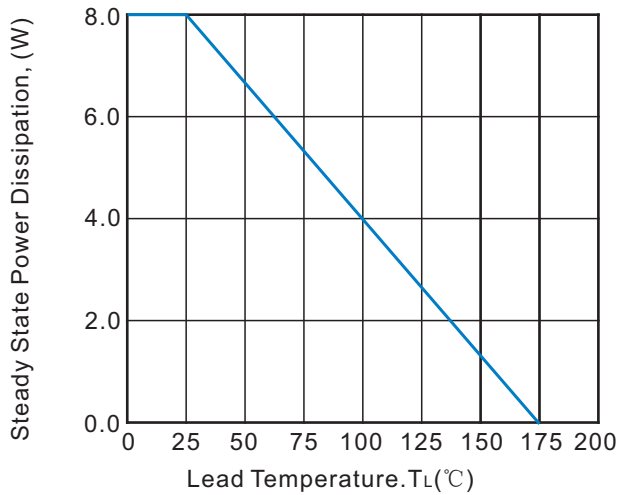

Fig.4 Peak Pulse Power Rating Cure

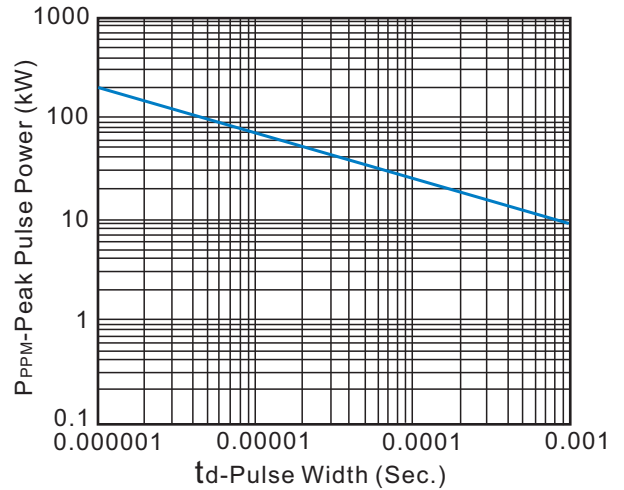
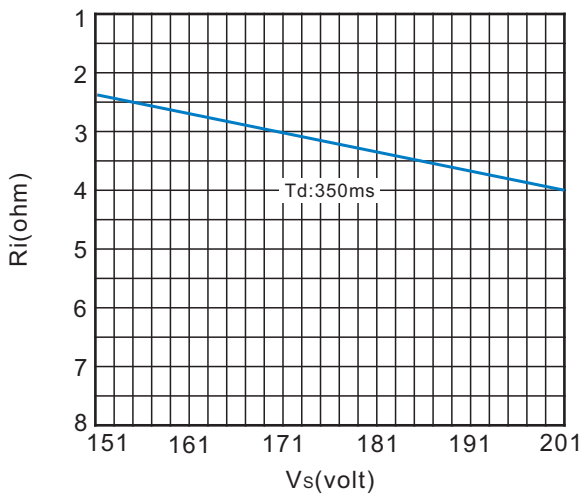

Fig.5 Ri-Vs chart for ISO-16750-2 Test A : 24V System



Recommended Soldering Conditions

Recommended Conditions

IR Reflow Condition		
Pre Heat	Temperature Min($T_{s(min)}$)	150°C
	Temperature Max($T_{s(max)}$)	200°C
	Time(Min to Max)(t_s)	60-180secs
Ramp up rate(150-200°C)		3°C/sec.Max.
Reflow	Temperature(T_L)(Liquidus)	220°C. Min.
	Temperature(t_L)	60-150secs
	Peak Temp(T_P)	+260(+0/-5)°C
Ramp up rate(220-200°C)		3°C/sec.Max.
Time within actual Peak Temp(t_P)		10-30 secs
Ramp-down Rate		5°C/sec.Max.
Time 25°C to Peak Temp(T_P)		6 min.Max.
Do not exceed		280°C

Reflow Soldering

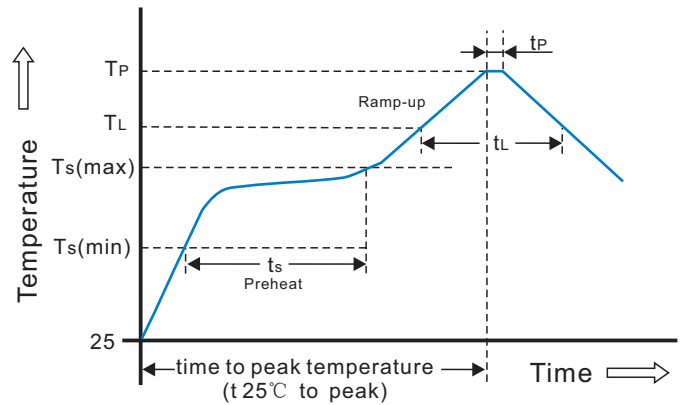

Marking Code

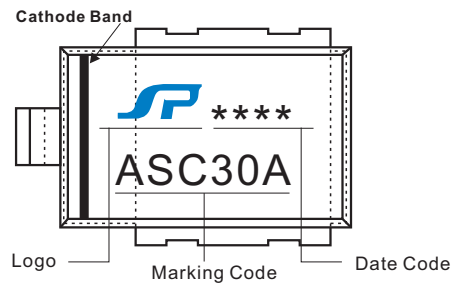

Tape And Reel Specification

Symbol	Ea Per Reel	REEL DIA (mm)	Industry Standard
ASC***	750	330	EIA RS-481

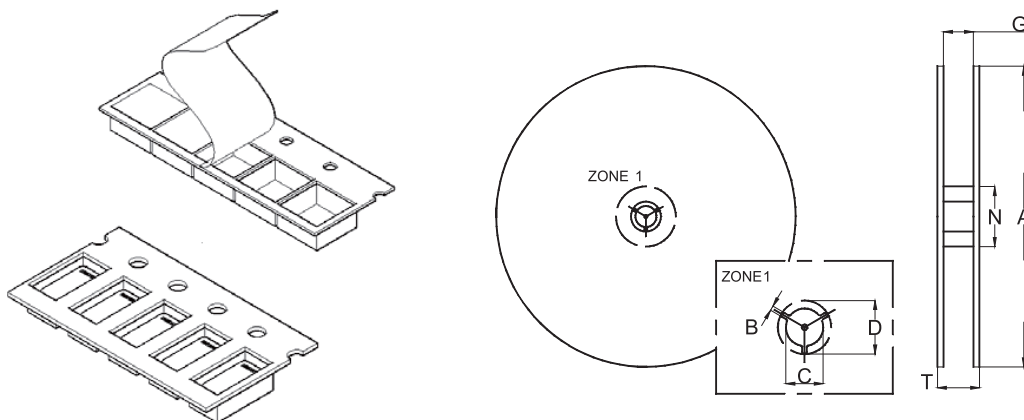

Tape Size	A Max.	B Min.	C	D Min.	N Min.	G Max.	T Max.
24(0.945)	330±2.0 (13.0±0.079)	1.5(0.059)	13.0±0.20 (0.51±0.0008)	20.2(0.795)	50(1.97)	26.4(1.039)	30.4(1.197)