

Gateway 72-UNIT Series

ETHERNET COMMUNICATION ADAPTOR

(Modbus use)

Functions & Features

- Bidirectional protocol converter for Modbus/TCP (Ethernet) and Modbus RTU (RS-485)
- Fast response time thanks to the Cache functions
- Expansion over 31 nodes is possible using additional 72EM2 units

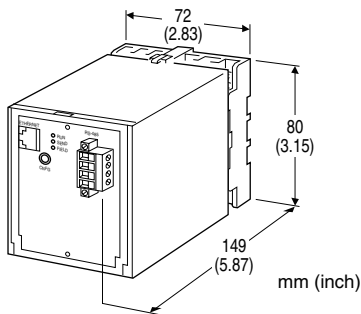

MODEL: 72EM2-M4-M2

ORDERING INFORMATION

Code number: 72EM2-M4-M2

POWER INPUT

AC Power

M2: 100 - 240 V AC (Operational voltage range 85 - 264 V, 47 - 66 Hz)

GENERAL SPECIFICATIONS

Construction: Plug-in

Connection

- **Ethernet:** RJ-45 modular jack
- **RS-485:** Euro type connector terminal
Unit side connector: MSTB2,5/4-GF-5,08AU
Cable side connector: MSTB2,5/4-STF-5,08AU
(Applicable wire size: 0.2 - 2.5 mm², stripped length 7 mm)

Recommended solderless terminal

- AI0,25-6BU 0.25 mm² (Phoenix Contact)
- AI0,34-6TQ 0.34 mm² (Phoenix Contact)
- AI0,5-6WH 0.5 mm² (Phoenix Contact)
- AI0,75-6GY 0.75 mm² (Phoenix Contact)
- AI1-6RD 1.0 mm² (Phoenix Contact)
- AI1,5-6BK 1.5 mm² (Phoenix Contact)

- **Power input:** M3.5 screw terminal

Screw terminal: Chromated steel

Housing material: Flame-resistant resin (black)

Isolation: Ethernet to RS-485 to FG to power

DIP SW Setting: Selection of IP Address and Maintenance/Normal operation

PC configuration: IP address and transmission speed are configured via a web browser software (provided by the user).

Internet Explorer 6.0 or higher

Status indicator

RUN: Green LED light flashes in normal operating conditions in 1-sec. cycles; 2-sec. cycles when configuring the unit.

SEND: Green LED light turns on when sending data to Ethernet.

FIELD: Green LED light turns on when sending data to RS-485.

Modbus RTU

- **Nodes:** Max. 31

Supported Commands

- Read Coil Status (01)
- Read Input Status (02)
- Read Holding Registers (03)
- Read Input Registers (04)
- Force Single Coil (05)
- Preset Single Register (06)
- Diagnostics (08)
- Fetch Comm. Event Counter (11)
- Fetch Comm. Event Log (12)
- Force Multiple Coils (15)
- Preset Multiple Registers (16)
- Report Slave ID (17)

Cache Commands

Following commands are valid for Cache function.

- Read Coil Status (01)
 - Read Input Status (02)
 - Read Holding Registers (03)
 - Read Input Registers (04)
- (Up to 100 queries)

ETHERNET COMMUNICATION

Standard: IEEE 802.3u

Transmission type: 10BASE-T, 100BASE-TX

Transmission speed: 10M or 100M bps
(Auto Negotiation)

Protocol: TCP/IP (compatible to Modbus/TCP Standard by Schneider Automation)

Number of connections: 8

Transmission media:

10BASE-T (STP cable; Category 5)

100BASE-TX (STP cable; Category 5e)

Maximum segment length: 100 meters

RS-485

Protocol: Modbus RTU

Response timeout: 10 - 10000 msec. (configured by PC)

Configuration: Bus type multi-drop

Standard: Conforms to TIA/EIA-485-A

Communication: Half-duplex, asynchronous, no procedure

Baud rate: 4.8 k or 9.6 k or 19.2 k or 38.4 kbps; default = 38.4 kbps (Start/Stop bit: 1 bit; Data bit: 8 bits; Parity: Odd)

Transmission distance: 500 meters max.

Transmission media: Shielded twisted-pair cable (CPEV-S 0.9 dia.)

INSTALLATION

Power consumption

•AC: Approx. 10 VA

Operating temperature: -5 to +55°C (23 to 131°F)

Operating humidity: 20 to 70 %RH (non-condensing)

Mounting: Surface or DIN rail

Weight: 450 g (0.99 lb)

PERFORMANCE

Insulation resistance: $\geq 100 \text{ M}\Omega$ with 500 V DC

Dielectric strength: 2000 V AC @ 1 minute

(Ethernet or FG to RS-485 to power)

500 V AC @ 1 minute (Ethernet to FG)

EXTERNAL VIEW

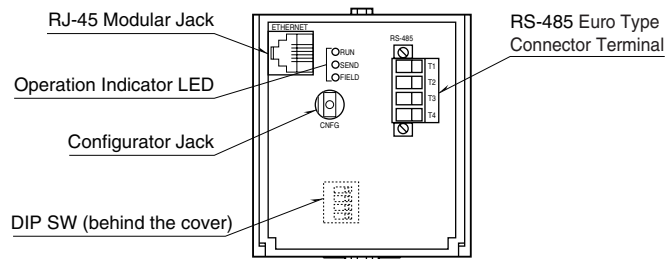

CONNECTION DIAGRAM

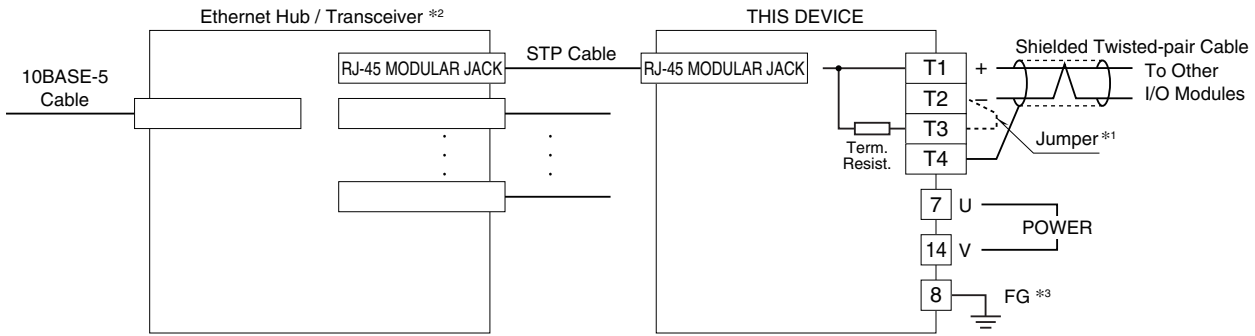

- *1. When the 72EM2 unit is located at an end of transmission line via twisted-pair cable (= when there is no cross wiring), close across the terminal 2 – 11 with the jumper attached to the product. Remove the jumper for all other units.
- *2. Install the 72EM2 and the Ethernet Hub/Transceiver inside the same panel. In order to extend outside the panel, use a 10BASE-5 cable.
- *3. Ground inside the same panel where the 72EM2 is installed.

CONNECTION EXAMPLE HOW TO CONNECT R3 AND R5 SERIES

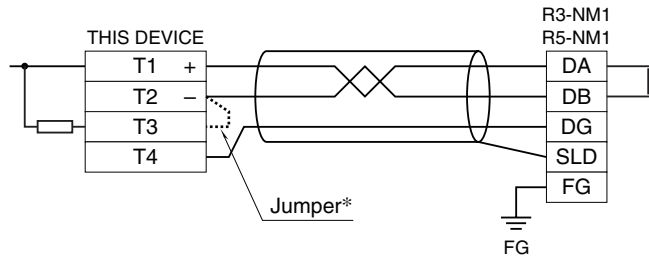

*Refer to * in CONNECTION DIAGRAM

Note: For other models, refer to each specification sheet and manual.

EXTERNAL DIMENSIONS & TERMINAL ASSIGNMENTS unit: mm (inch)

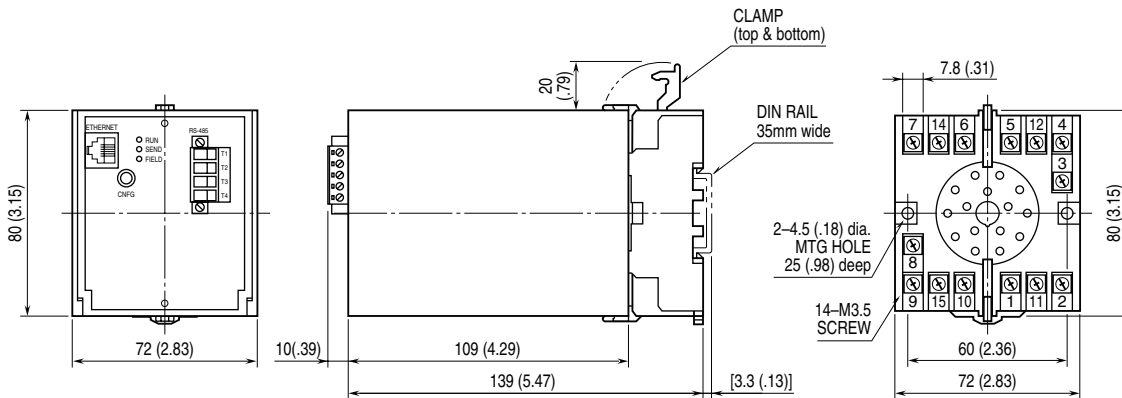

MOUNTING REQUIREMENTS unit: mm (inch)

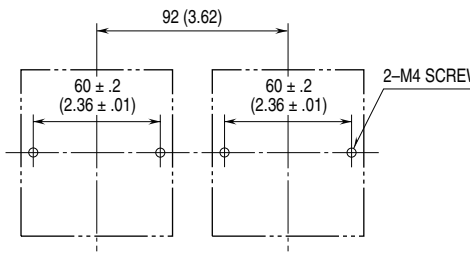

SYSTEM CONFIGURATION EXAMPLES

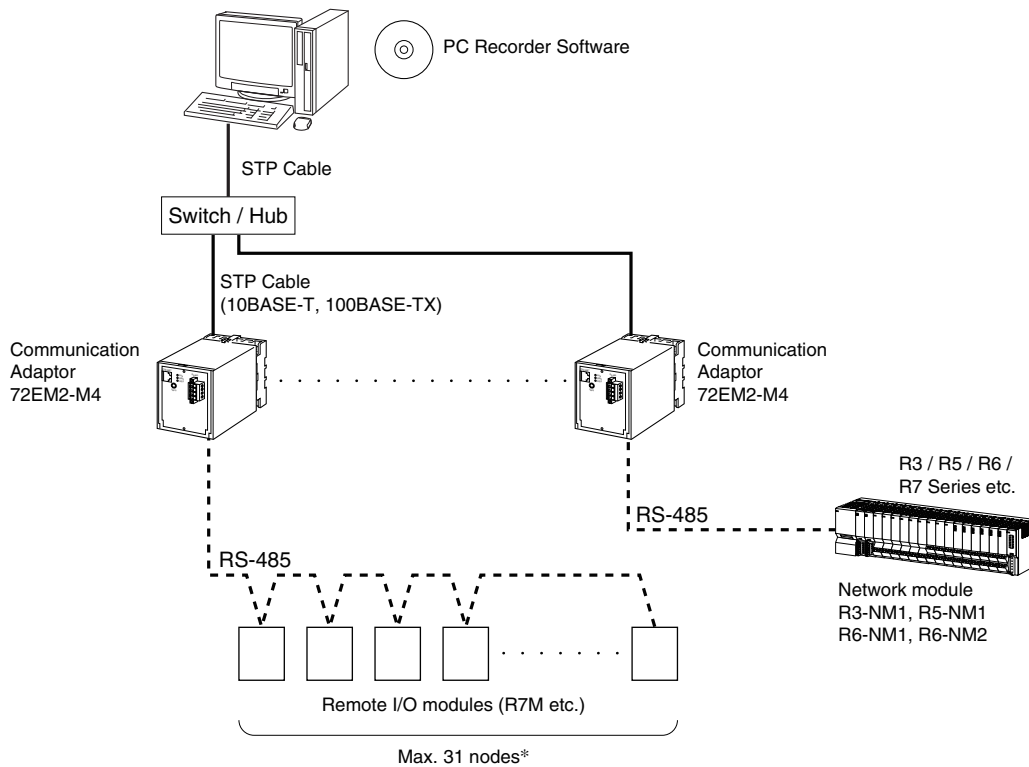

* The number of nodes actually connected is limited by setting range of the module.



Specifications are subject to change without notice.