

# LDAN222T1G

## S-LDAN222T1G

Common Cathode Silicon  
Dual Switching Diode

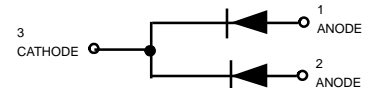
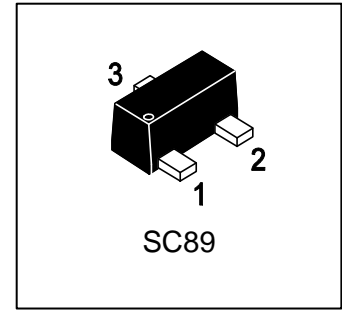

### 1. FEATURES

- Fast Trr
- Low CD
- We declare that the material of product compliance with RoHS requirements and Halogen Free.
- S- prefix for automotive and other applications requiring unique site and control change requirements; AEC-Q101 qualified and PPAP capable.

### 2. DEVICE MARKING AND RESISTOR VALUES

Device	Marking	Shipping
LDAN222T1G	N9	3000/Tape&Reel
LDAN222T3G	N9	10000/Tape&Reel

### 3. MAXIMUM RATINGS(Ta = 25°C)

Parameter	Symbol	Limits	Unit
Reverse Voltage	VR	80	V
Peak Reverse Voltage	VRM	80	V
Forward Current	IF	100	mA
Peak Forward Current	IFM	300	mA
Peak Forward Surge Current(Note 1)	IFSM	2	A

### 4. THERMAL CHARACTERISTICS

Parameter	Symbol	Limits	Unit
Power Dissipation	PD	150	mW
Junction Temperature	Tj	150	°C
Storage Temperature Range	Tstg	-55~+150	°C

1. t = 1 μS

**5. ELECTRICAL CHARACTERISTICS (Ta= 25°C)**

Characteristic	Symbol	Min.	Typ.	Max.	Unit
Reverse Voltage Leakage Current (VR = 70 V)	IR	-	-	0.1	μA
Forward Voltage (IF = 100 mA)	VF	-	-	1.2	V
Reverse Breakdown Voltage (IR = 100 μA )	VR	80	-	-	V
Diode Capacitance (VR = 6.0 V, f = 1.0 MHz)	CD	-	-	3.5	pF
Reverse Recovery Time (IF = 5.0 mA, VR = 6.0 V, RL = 100 Ω, Irr = 0.1 IR)	Trr	-	-	4.0	ns

**6.ELECTRICAL CHARACTERISTICS CURVES**

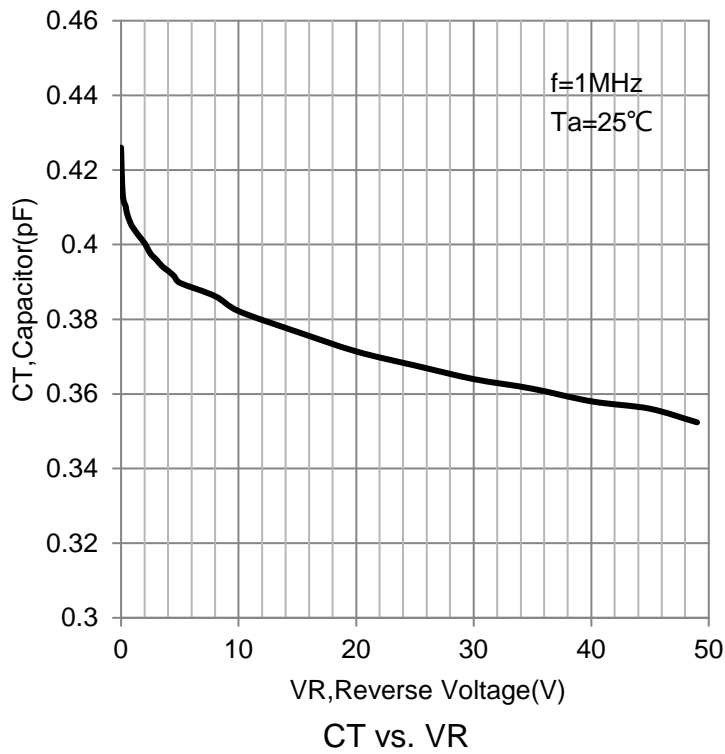
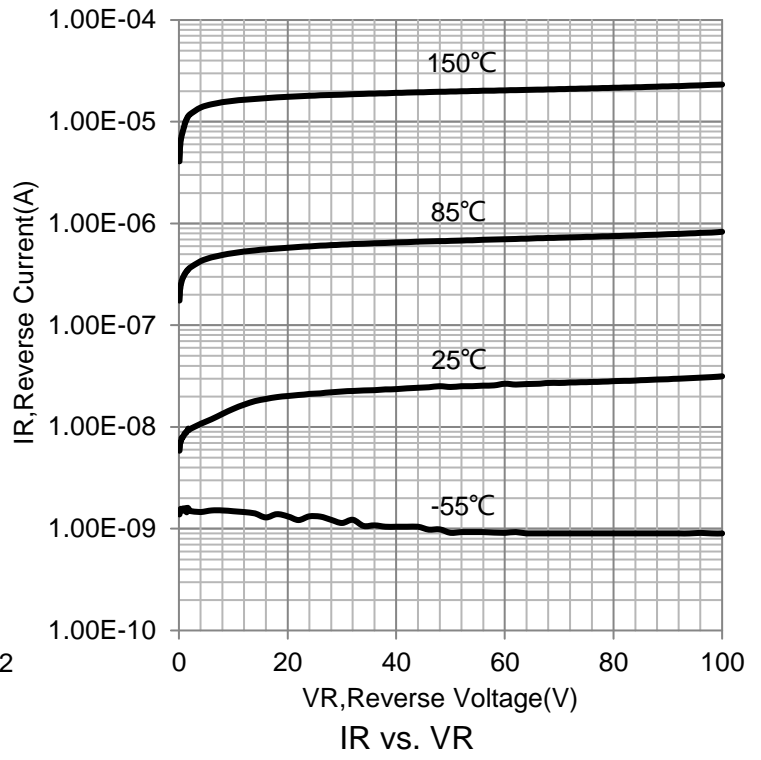
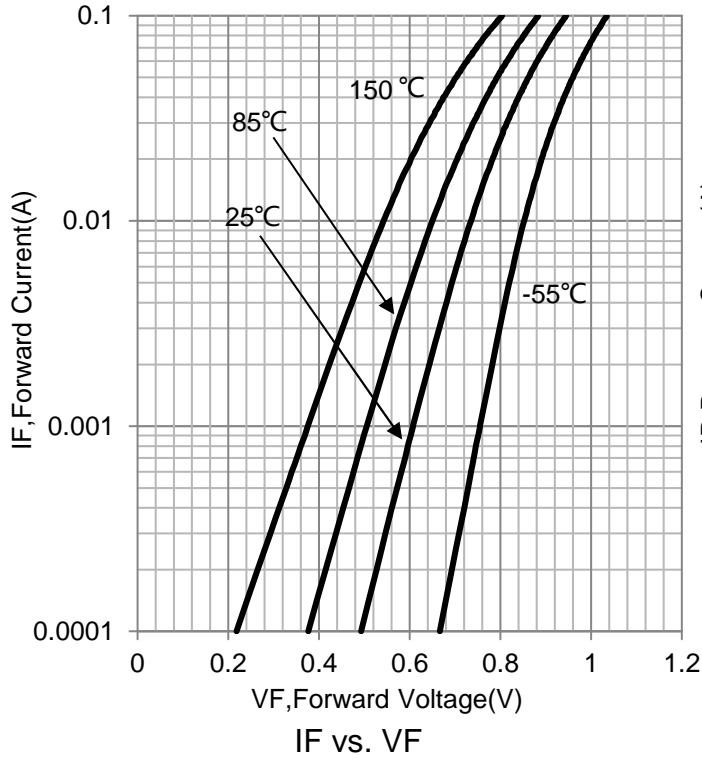

### 7. OUTLINE AND DIMENSIONS

Notes:

1. DIMENSIONING AND TOLERANCING PER ANSI Y14.5M, 1982.
2. CONTROLLING DIMENSION: MILLIMETERS.
3. MAXIMUM LEAD THICKNESS INCLUDES LEAD FINISH. MINIMUM LEAD THICKNESS IS THE MINIMUM THICKNESS OF BASE MATERIAL.
4. DIMENSIONS A AND B DO NOT INCLUDE MOLD FLASH, PROTRUSIONS OR GATE BURRS.

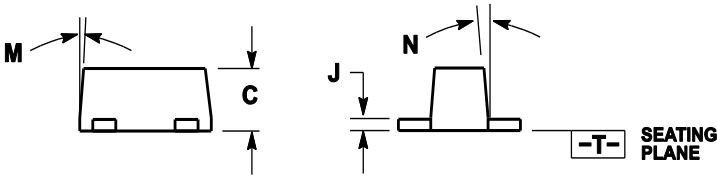
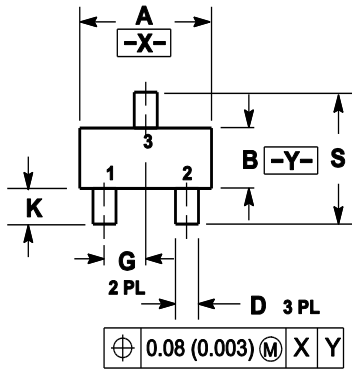

DIM	MILLIMETERS			INCHES		
	MIN	NOM	MAX	MIN	NOM	MAX
A	1.50	1.60	1.70	0.059	0.063	0.067
B	0.75	0.85	0.95	0.030	0.034	0.040
C	0.60	0.70	0.80	0.024	0.028	0.031
D	0.23	0.28	0.33	0.009	0.011	0.013
G	0.50BSC			0.020BSC		
H	0.53REF			0.021REF		
J	0.10	0.15	0.20	0.004	0.006	0.008
K	0.30	0.40	0.50	0.012	0.016	0.02
L	1.10REF			0.043REF		
M	---	---	10°	---	---	10°
N	---	---	10°	---	---	10°
S	1.50	1.60	1.70	0.059	0.063	0.067

### 8. SOLDERING FOOTPRINT

