

SD Memory Card Connectors CIM-F22

FEATURES

1. SMT-type SD memory card connector.
2. Outstanding touch! 8mm stroke type with push-in push-out eject mechanism.
3. Card detection switch and write protect switch provided.
4. Ideal for saving space on the board! Stand-off height is only 1.8mm (connector height is ultra-thin, at 2.8mm).
5. Reverse type also available.
6. Half-lock provided to prevent the card from falling out.

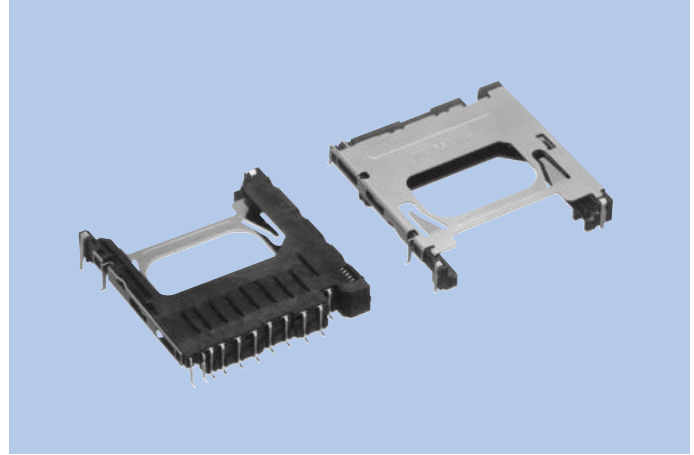

HOW TO ORDER

F22-009-21 0-A G G E-

1 2 3 4 5 6 7 8 9

- 1 Series No. (F22)
- 2 No. of contacts (009 : 9pins)
- 3 Housing material (21 : LCP resin)
- 4 UL grade (0 : UL94V-0)
- 5 Contact plating (A : Gold)
- 6 Contact plating thickness (G : 0.3μm)
- 7 Contact style (G : Angle)
- 8 Package (E : Taping)
- 9 Supplementary symbol
 ST : Standard type
 RT : Reverse type
 RB : Reverse B type

SPECIFICATIONS

CHARACTERISTICS

Rated Voltage	AC 50V (rms)
Rated Current	0.5A
Withstanding Voltage	500V AC (rms) 1minute
Insulation Resistance	1000MΩ min. (at 500V DC)
Contact Resistance	100mΩ max.

MECHANICAL CHARACTERISTICS

Life (Matching Cycle)	10,000 times
Card Insertion Force	4.9N (0.5kgf) ~9.8N (1kgf)
Eject Force	4.9N (0.5kgf) ~9.8N (1kgf)
Using temperature Range	-25~+90°C

MATERIAL & FINISH

Component Parts	Material	Finish
Housing	LCP resin	(Black)
Contact	Copper Alloy	Gold plating
CD Switch	Copper Alloy	Gold plating
CD · WP Switch	Copper Alloy	Gold plating
WP Switch	Copper Alloy	Gold plating
Wing	Copper Alloy	Gold plating
Plate	SUS	-
Slider	PPA resin	(Black)
Coil Spring	SUS	-
Lock Pin	SUS	-

DIMENSIONS

Standard type

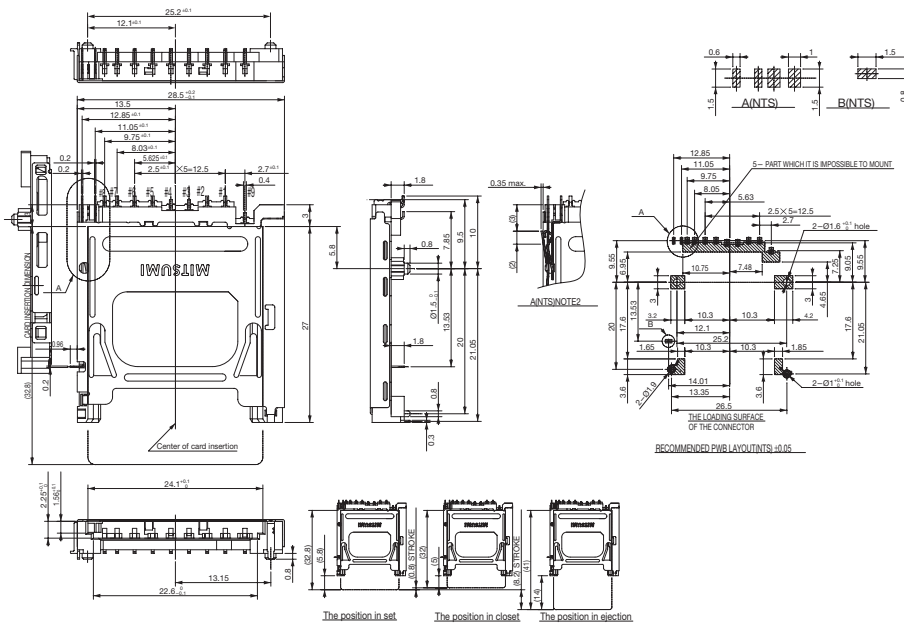

Unit: mm
☆ Tolerance: ±0.3

Reverse type

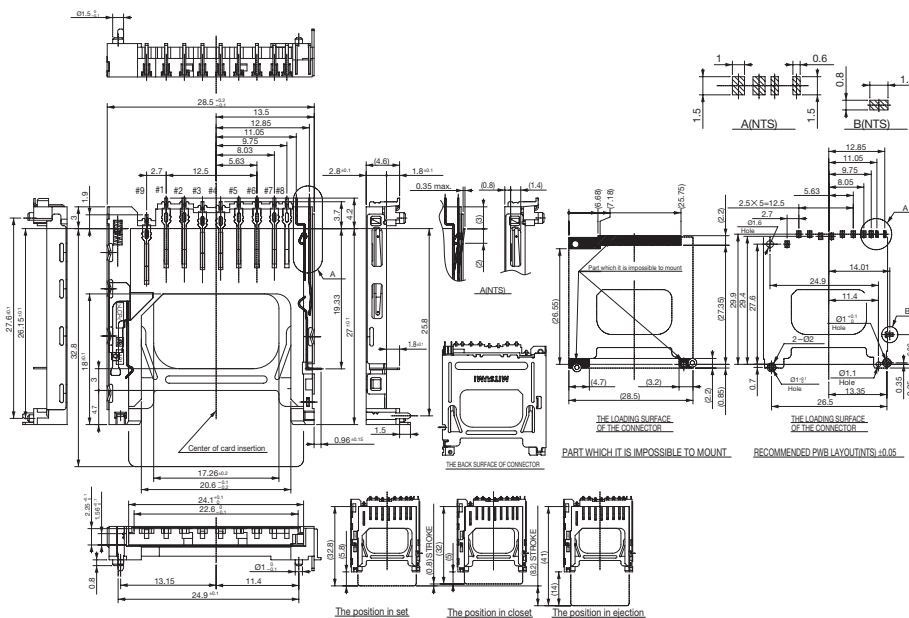

Unit: mm
☆ Tolerance: ±0.3