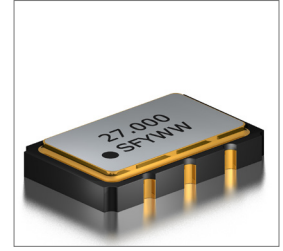

Features
<ul style="list-style-type: none"> <li>±20ppm (Frequency Stability) Available</li> <li>Ceramic Package</li> <li>CMOS</li> <li>Programmed VCXO</li> <li>Tape and Reel</li> </ul>

Applications
<ul style="list-style-type: none"> <li>Micro Processors</li> <li>FPGA</li> <li>Storage Area/Networking</li> <li>Digital Video</li> <li>Portable Computers</li> </ul>

**Part Numbering Guide**
**SQV 53 C 3 A 48 A 2 - 27.000M**

 SUNTSU QUICK  
 TURN VCXO

5.0mm x 3.2mm

CMOS

**SUPPLY VOLTAGE**

 2 : 2.5V±5%  
 3 : 3.3V±5%

**FREQUENCY STABILITY**

 A : ±50ppm  
 B : ±30ppm  
 C : ±25ppm  
 D : ±20ppm  
 \*E : ±15ppm

**OPERATING  
 TEMPERATURE RANGE**

 07 : 0°C - +70°C  
 16 : -10°C - +60°C  
 17 : -10°C - +70°C  
 27 : -20°C - +70°C  
 38 : -30°C - +85°C  
 48 : -40°C - +85°C

**PULLABILITY**

 A : ±150ppm  
 B : ±100ppm  
 C : ±80ppm  
 D : ±50ppm

**FREQUENCY**  
 MHz

**TRI-STATE  
 (ENABLE/DISABLE)**  
 BLANK : No Connect  
 2 : Pin 2

Cage Code: 4GUT4

To customize your parameters contact a Suntsu representative.

\* For frequency stability option E contact a Suntsu representative.

Electrical Parameters	Units	Minimum	Typical	Maximum	Remarks
Frequency Range	MHz	8		1500	
Frequency Stability (Includes Initial Tolerance at 25°C, Frequency Stability over Operating Temperature, Output Load Change, Supply Voltage Change, and First Year Aging at 25°C.)	ppm	-20		+20	See part numbering guide for options.
Operating Temperature	°C	-40		+85	See part numbering guide for options.
Storage Temperature	°C	-55		+125	
Supply Voltage (V <sub>DD</sub> ) 2.5V Option	V	2.375	2.5	2.625	
Supply Voltage (V <sub>DD</sub> ) 3.3V Option	V	3.135	3.3	3.465	See part numbering guide for options.
Current (I <sub>DD</sub> ) 2.5V Option	mA			35	
Current (I <sub>DD</sub> ) 3.3V Option	mA			45	
Current Voltage (V <sub>C</sub> ) 2.5V Option	V	0		2.5	
Current Voltage (V <sub>C</sub> ) 3.3V Option	V	0		3.3	
Pullability	ppm	±50	±100	±150	See part numbering guide for options.
Linearity	%			10	
Output Load (CMOS)	pF			15	
Output Logic HIGH Level (V <sub>OH</sub> )	V	0.9*V <sub>DD</sub>			
Output Logic LOW Level (V <sub>OL</sub> )	V			0.1*V <sub>DD</sub>	
Rise (T <sub>R</sub> ) And Fall (T <sub>F</sub> ) Time	ns			3	
Symmetry (Duty Cycle)	%	45	50	55	
Tri-State Input Voltage - Enable	V	0.7*V <sub>DD</sub>			
Tri-State Input Voltage - Disable	V			0.3*V <sub>DD</sub>	
Start-Up Time	ms			10	
Phase Jitter (12KHz ~ 20MHz)	ps		0.7	1.5	

**Outline Drawing & Land Pattern**

All dimensions are in millimeters (mm) unless otherwise noted. Drawings are not to scale.

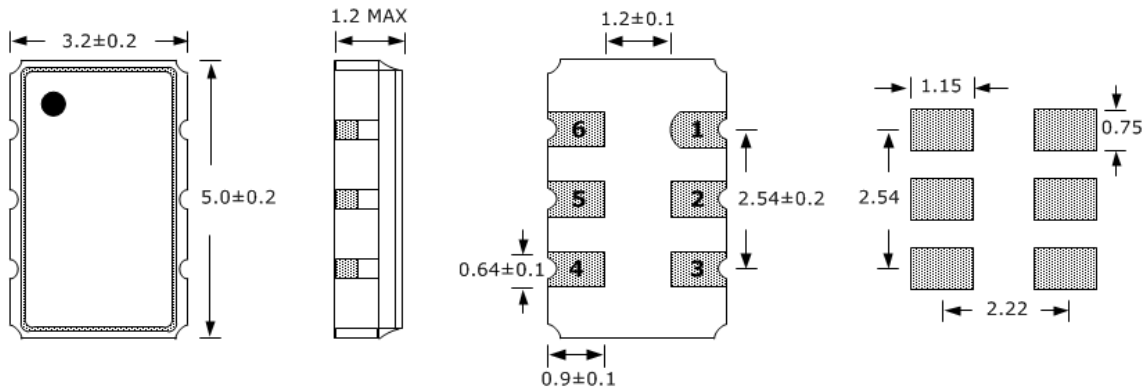

PIN	FUNCTION
1	VOLTAGE CONTROL
2	TRI-STATE or NC
3	GND
4	OUTPUT
5	NC
6	V <sub>DD</sub>

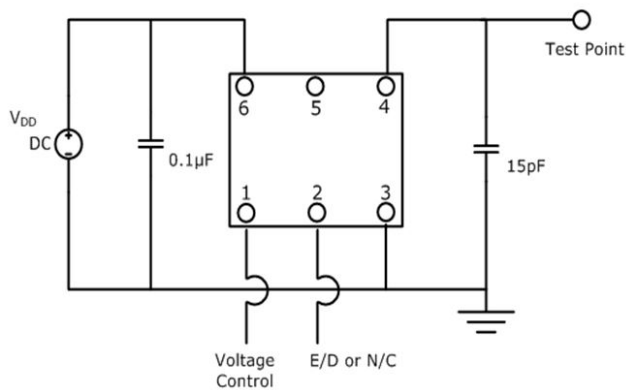
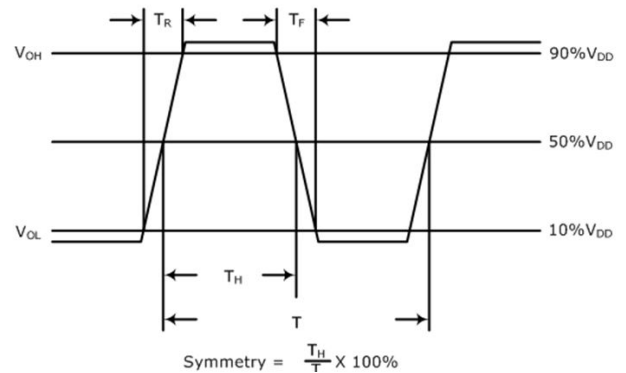
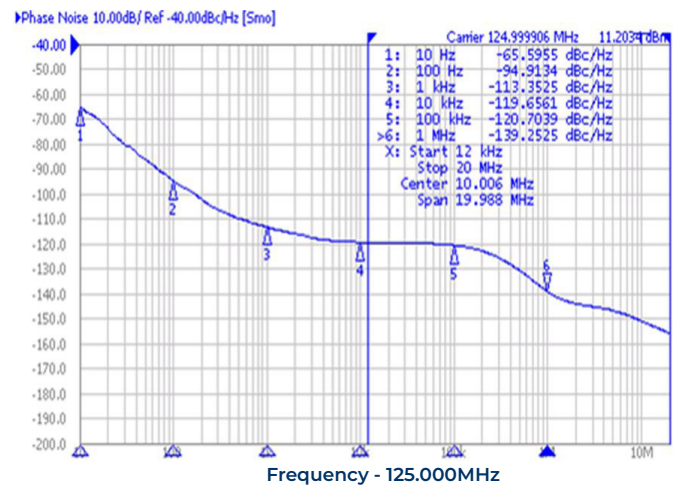
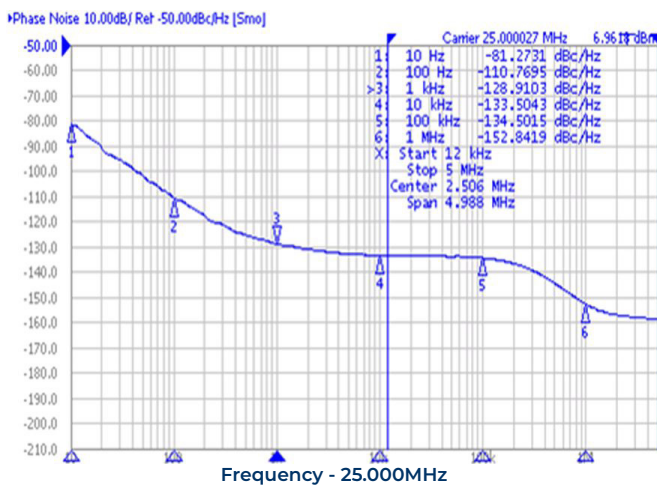
**Test Circuit (CMOS)**

**Waveform (CMOS)**

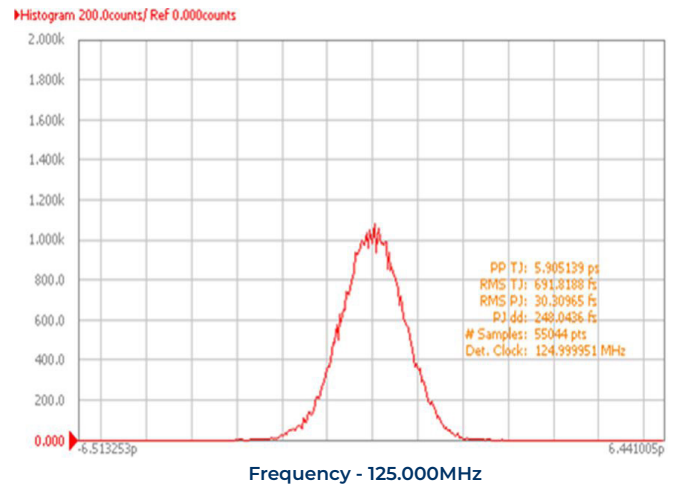
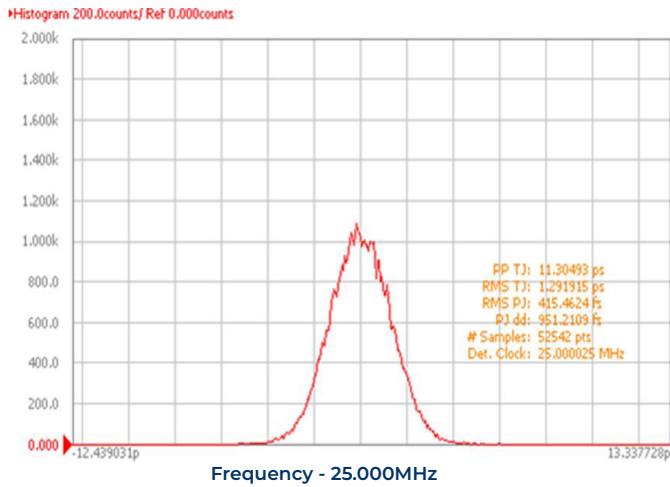
**Typical Phase Noise Performance (Measured By Agilent E5052A)**

### Typical Jitter Performance (Measured By Agilent E5052A)

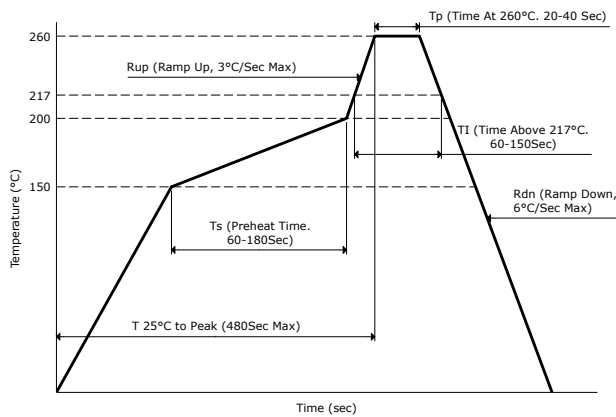

### Reflow Profile



### Part Marking

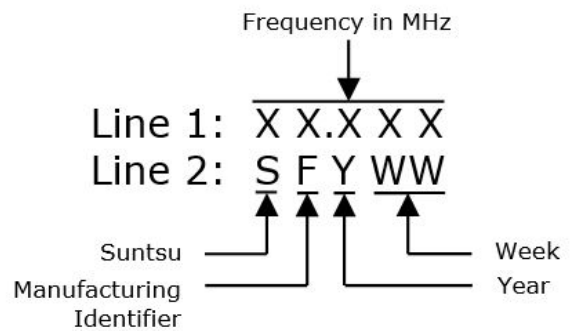

### Tape And Reel Dimensions

All dimensions are in millimeters (mm) unless otherwise noted. Drawings are not to scale.

1,000pcs/Reel

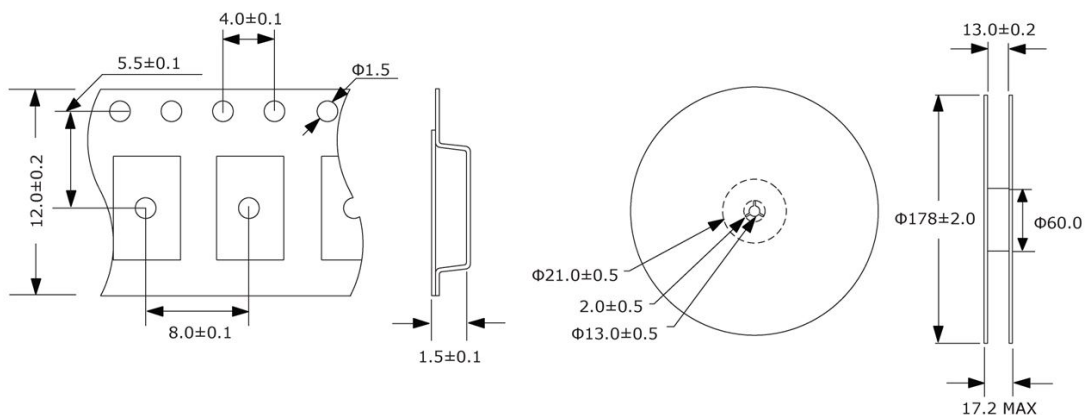

Environmental Specifications		Mechanical Specifications	
Temperature Cycling	MIL-STD-883, Method 1010, Condition B	Mechanical Shock	MIL-STD-202, Method 213, Condition B
Fine Leak Test	MIL-STD-883, Method 1014, Condition A	Vibration	MIL-STD-883, Method 2007, Condition A
Gross Leak Test	MIL-STD-883, Method 1014, Condition C	Moisture Resistance	MIL-STD-883, Method 1004
Solderability	MIL-STD-883, Method 2003	Resistance to Solvents	MIL-STD-202, Method 215
Moisture Sensitivity	J-STD-020, MSL 1	Resistance to Soldering Heat	MIL-STD-202, Method 210, Condition K