



050-316

PRODUCT BRIEF

100 MBPS-5 GBPS PC BOARD MOUNT DUAL-TRANSMITTER
(2) 850NM VCSEL TRANSMITTERS
SMALL & COMPACT WITH RUGGED CONSTRUCTION FOR
HARSH ENVIRONMENTS

REV	DESCRIPTION	DATE	APPROVED
A	Initial Release	1/16/2015	SZ
B	Per DCN53850	2/6/2015	SZ
C	Per DCN55452 (revised Samtec connector part numbers)	05/28/15	TC

BF15U2-1912

THIS COPYRIGHTED DOCUMENT IS THE PROPERTY OF GLENAIR, INC. AND IS FURNISHED ON THE CONDITION THAT IT IS NOT TO BE DISCLOSED, REPRODUCED IN WHOLE OR IN PART, OR USED TO SOLICIT QUOTATIONS FROM COMPETITIVE SOURCES, OR USED FOR MANUFACTURE BY ANYONE OTHER THAN GLENAIR, INC. WITHOUT WRITTEN PERMISSION FROM GLENAIR, INC. THE INFORMATION HEREIN HAS BEEN DEVELOPED AT GLENAIR'S EXPENSE AND MAY BE USED FOR ENGINEERING EVALUATION AND INCORPORATION INTO TECHNICAL SPECIFICATIONS AND OTHER DOCUMENTS WHICH SPECIFY PROCUREMENT OF PRODUCTS FROM GLENAIR, INC.

050-316 Product Brief
PC Board Mount Dual-Transmitter
100 Mbps – 5 Gbps, MMF, 3.3V



PC Board Mount Fiber Optic Dual-Transmitter, 100M-5Gbps, MMF, 3.3V

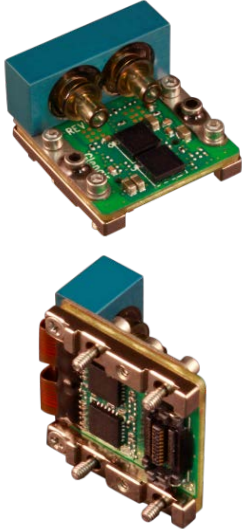

Glenair 050-316, is a ruggedized harsh environment PC Board Mount Dual-transmitter with electrical and optical functionality similar to transmitters in SFP dual-transmitters but with mechanical design that is suited to the harsh temperature and vibration environments found in the Military, Aerospace, Railway, Oil and Gas, and Industrial applications. The board mount optical dual-transmitters also support optional Digital Monitoring Interface (DMI) features in accordance with SFF 8472. The dual-transmitter interfaces with a host board through a high speed electrical connector.

Each transmitter includes a Transmitter Optical Subassembly (TOSA) and laser driver circuitry. The TOSA, containing an 850 nm VCSEL (Vertical Cavity Surface Emitting Laser) light source, is located at the optical interface and mates with the GC optical connector. The TOSA is driven by a laser driver, which converts differential logic signals into an analog laser diode drive current. This laser driver circuit regulates the optical power at a constant level provided the data pattern is DC balanced (for example 8B10B encoding).

KEY FEATURES/BENEFITS

- SFP Compatible Electrical Input signal levels
- 850nm VCSEL lasers to support up to 5 Gbps
- Industry standard CML input and outputs that make for simple integration on customer host PCB
- Glenair Rugged GC Optical connector for high shock and vibration applications
- Dual-transmitter is securely mounted with screws to PCB to ensure excellent shock and vibration performance
- High-Speed Electrical plug-in connector eliminates the need for soldering & enables ease of servicing
- Captive screws to simplify manufacturing logistics and assembly
- Small: Approx. 0.8" x 0.9" x 0.5"
- -40°C to +85°C Operating Case Temperature
- Glenair fiber jumpers available to connect from dual-transmitter to any Glenair Mil/Aero Fiber Optic Connector Style
- Evaluation fixtures available
- Optional Digital Diagnostic and Monitoring (DMI) based on SFF-8472, enables monitoring of:
 - Transmitted optical power for each channel
 - Laser bias current per laser
 - Temperature
 - Supply voltage

APPLICATIONS

- Harsh Environment such as: Airborne, Tactical, Railway, Industrial, Oil and Gas and Shipboard
 - Ethernet, Fibrechannel, 1x, 2x, 4x, SFPDP

HOW TO ORDER

Table 1 Part Number Options

Part Number	Description
050-316-1	100Mbps-2.5Gbps, without DMI
050-316-1-D	100Mbps-2.5Gbps, with DMI
050-316-2	2.5Gbps-5Gbps, without DMI
050-316-2-D	2.5Gbps-5Gbps, with DMI

050-316 Product Brief
PC Board Mount Dual-Transmitter
100 Mbps – 5 Gbps, MMF, 3.3V



Ratings and Specifications

TABLE 2 ABSOLUTE MAXIMUM RATINGS

Parameter	Symbol	Min	Typ	Max	Units	Notes
Storage Temperature	T _s	-55		+100	°C	
Supply Voltage	V _{cc}	-0.4		3.8	V	V _{ccT} & V _{ccR} may not differ by more than 0.5V

TABLE 3 OPERATING CONDITIONS

Parameter	Symbol	Min	Typ	Max	Units	Notes
Operating Temperature, Case	T _{op}	-40		+85	°C	
Supply Voltage	V _{cc}	3.135	3.3	3.465	V	
Supply Current	I _{cc}		180	200	mA	Typical @ +85°C
Power Supply Noise (Peak-Peak)	V _{cc_ripple}			100	mV	

TABLE 4 ELECTRO-OPTICAL CHARACTERISTICS – TRANSMITTER

Parameter	Symbol	Min	Typ	Max	Units	Notes
Optical Output Power	P _{OUT}	-6.5	-5	-1	dBm	850nm VCSEL
Extinction Ratio, 1.25Gbps	E _r	7	10		dB	Exceeds OMA for GbE, 1FC
Extinction Ratio, 2.125 Gbps & 4.25 Gbps	E _r	6			dB	Exceeds OMA for 2FC & 4FC
Optical Wavelength	λ _{OUT}	830	850	860	nm	
Spectral Width, rms	Δλ			0.85	nm	
Relative Intensity Noise	RIN			-117	dB/Hz	
Transmitter Differential Input Impedance	Z _{in}		100		Ohms	AC coupled Internally
Differential Input Voltage	V _{in_d}	250		2200	mV _{p-p}	CML, 100 ohm

TABLE 5 RESERVED

Parameter	Symbol	Min	Typ	Max	Units	Notes

050-316 Product Brief
PC Board Mount Dual-Transmitter
100 Mbps – 5 Gbps, MMF, 3.3V



Ratings and Specifications (continued)

TABLE 6 COMPLIANCE SPECIFICATIONS

CHARACTERISTIC	Standard	Condition	Notes
Mechanical Shock	MIL-STD-810	Para. 516.6, proc. I, 650g	0.9 ms operating
Mechanical Vibration	MIL-STD-810	Para. 514.6, 40g rms	Random, operating
ESD	MIL-STD-883		1000V HBM
Flame Resistance	MIL-STD-1344	Method 1012, Cond. B	30 seconds
Damp Heat	MIL-STD-1344	Method 1002.2, Cond. B	10 cycles , 24 hours
Eye Safety	CDRH and IEC-825	Class 1 Laser Product	

050-316 Product Brief
PC Board Mount Dual-Transmitter
100 Mbps – 5 Gbps, MMF, 3.3V



FIGURE 1 - OUTLINE DRAWING CONTINUED (MARKING)

LABELING:

Each unit will be shipped in an antistatic bag. The label on the antistatic bag shall be at a minimum Arial size 10 black font and contain at a minimum the following information:

ANTISTATIC BAG LABEL:

Glenair
Cage Code (06324)
Part Number (PN 050-xxx as required)
Date Code (DC xxxx)
Serial Number (SN 123456)

Each unit will be marked, either with a label or laser engraving, as follows:

1. Marking font to be Arial, greater than .08 inches in height.
2. Minimum Marking on each part will include the following:
 - Glenair
 - Serial number
 - Glenair Part Number

Example Minimum Marking:

GLENAIR SN123456
050-316-1-D

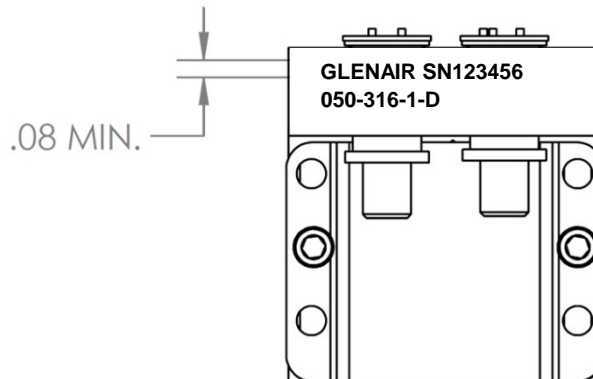

FUNCTIONAL DESCRIPTION

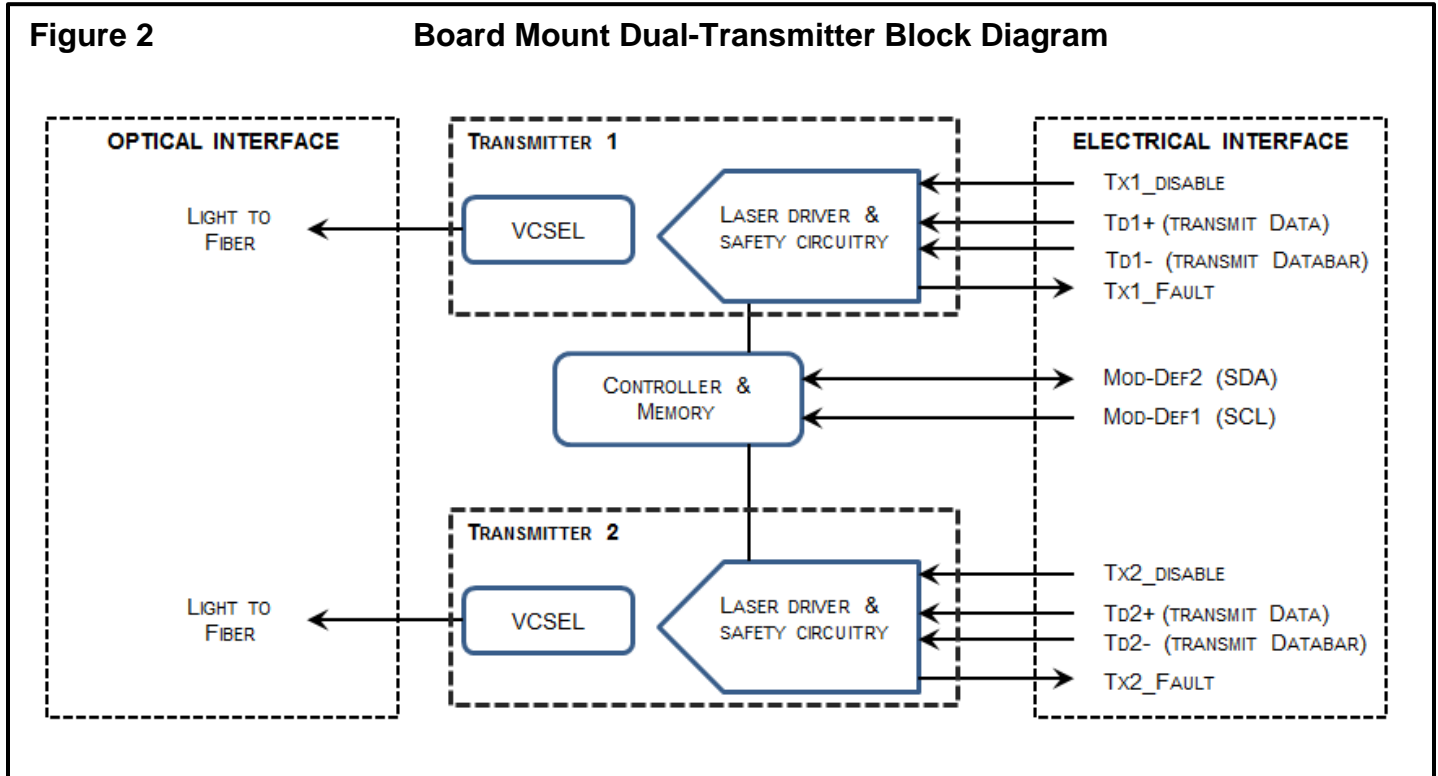

TRANSMITTER SECTION

Transmit Disable (TX1_Disable and TX2_Disable)

The transmitters accept a TTL and CMOS compatible transmit disable control signal input that shuts down the transmitter optical output. A high signal disables the transmitter while a low signal allows normal dual-transmitter operation. Also laser is disabled when TX Disable is open. In the event of a fault (e.g. eye safety circuit activated), cycling this control signal resets the module. Host systems should allow a 10ms interval between successive assertions of this control signal.

Transmit Fault (TX1_FAULT and TX2_FAULT)

A catastrophic laser fault will activate the transmitter signal, TX*_FAULT, and disable the laser. This signal is an open collector output (pull-up required on the host board). A low signal indicates normal laser operation and a high signal indicates a fault. The TX*_FAULT will be latched high when a laser fault occurs and is cleared by toggling the TX*_DISABLE input or cycling the power of the dual-transmitter. The transmitter fault condition can also be monitored via the optional 2-wire serial interface (address A2, byte 110, bit 2).

Eye Safety Circuit

050-316 Product Brief
PC Board Mount Dual-Transmitter
100 Mbps – 5 Gbps, MMF, 3.3V



The Transmitters provides Class 1 eye safety by design and is compliant with US FDA CDRH AEL Class 1 and EN(IEC) 60825-1,2, EN60950 Class 1. The eye safety circuit continuously monitors optical output power levels and will disable the transmitter and assert a TX_FAULT signal upon detecting an unsafe condition. Such unsafe conditions can be created by inputs from the host board (Vcc fluctuation, unbalanced code) or faults within the module.

FUNCTIONAL I/O

The PC board mount dual-transmitter accepts industry standard differential signals such as LVPECL and CML within the scope of the SFP MSA. To simplify board requirements, transmitter bias resistors and ac coupling capacitors are incorporated, per SFF-8074i, and hence are not required on the host board. The module is AC-coupled and internally terminated.

Figure 3 illustrates a recommended interface circuit to link the PC board mount dual-transmitter to the supporting Physical Layer integrated circuits.

The PC board mount dual-transmitter interfaces with the host circuit board through twenty I/O pins identified by function in Table 7. The dual-transmitter high speed transmit and receive interfaces require SFP MSA compliant signal lines on the host board. The TX1_DISABLE, TX2_DISABLE, TX1_FAULT and TX2_FAULT require TTL lines on the host board (per SFF-8074i) if used. If an application chooses not to take advantage of the functionality of these pins TX1_Disable and TX2_Disable need to be tied to GND, TX1_Fault , TX2_Fault do not need to be connected.

050-316 Product Brief
 PC Board Mount Dual-Transmitter
 100 Mbps – 5 Gbps, MMF, 3.3V



FIGURE 3 RECOMMENDED BOARD MOUNT DUAL-TRANSMITTER HOST BOARD SCHEMATIC

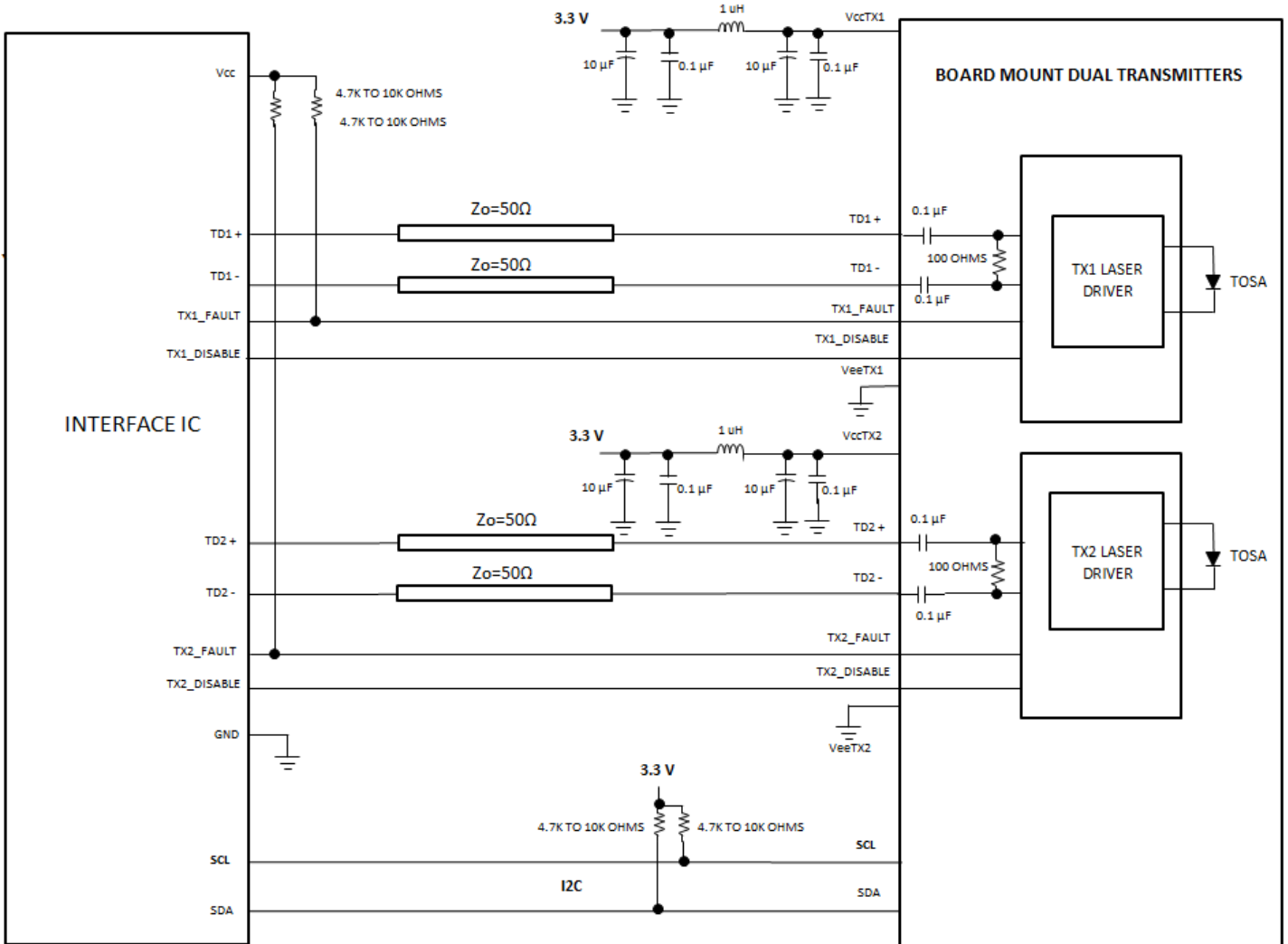

050-316 Product Brief
PC Board Mount Dual-Transmitter
100 Mbps – 5 Gbps, MMF, 3.3V



Digital Diagnostic Interface and Serial Identification (EEPROM)

The PCB mount Dual-Transmitter is derived from the SFF-8074i SFP specification and with SFF-8472, the SFP specification for Digital Diagnostic Monitoring Interface, but modified to account for Dual-Transmitter functionality. Both specifications can be found at <http://www.sffcommittee.org>.

FIGURE 4 – DIGITAL DIAGNOSTIC MEMORY MAP OVERVIEW

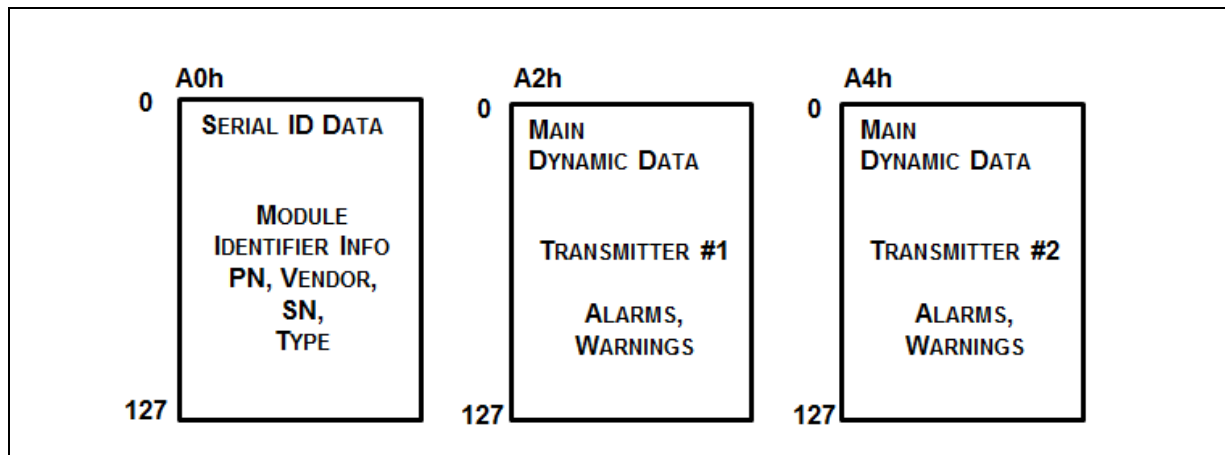

The PCB mount Dual-Transmitter features EEPROM for Serial ID, which contains the product data stored for retrieval by host equipment. This data is accessed via the 2-wire serial EEPROM protocol of the ATMEL AT24C01A or similar, derived from with the industry standard SFP Multi-Source Agreement but modified to account for Dual-Transmitter functionality. The base EEPROM memory, bytes 0-255 at memory address A0h, is organized in compliance with SFF-8074i.

Required Host Board Components

A power supply noise rejection filter as describe in SFP MSA is required on the host PCB to meet data sheet performance. This filter incorporates an inductor which should be rated 400 mADC and 1 Ω series resistance or better. It should not be replaced with a ferrite. The required filter is illustrated in Figure 4. Also, the host PCB for the board mount dual-transmitter requires 4.7 K to 10 K Ω pull-up resistors for TX1_FAULT, TX2_FAULT, SCA and SDL lines.

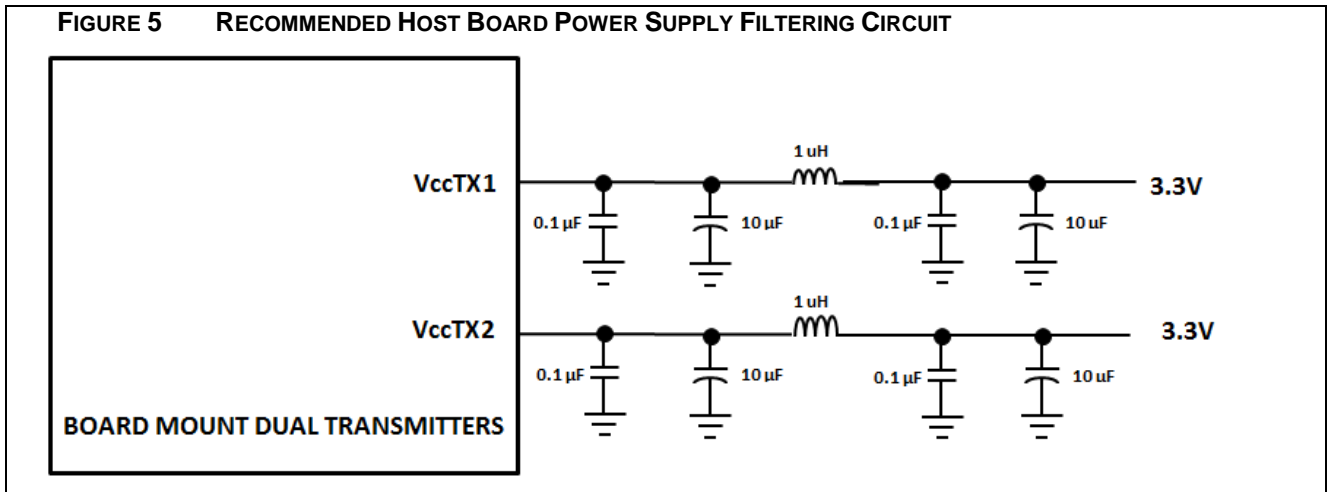

Fiber Compatibility

The dual-transmitter is capable of transmission at 2 to 550 meters with 50/125 μ m fiber, and at 2 to 275 meters with 62.5/125 μ m fiber, for 1.25 GBd Ethernet. It is capable of transmission up to 550m with 50/125 μ m fiber and up to 300m with 62.5/125 μ m fiber, for 1.0625 GBd Fiber Channel.

Electrostatic Discharge (ESD)

The Dual-transmitter is compatible with ESD levels found in typical manufacturing and operating environments as described JEDEC EIA JESD22-A114-A, Class 1 (<2000Volts) HBM. Glenair recommends that devices are handled with ESD precautions to limit exposure to below 500V HBM.

There are two design cases in which immunity to ESD damage is important. The first case is during handling of the dual-transmitter prior to insertion to the host board. To protect the dual-transmitter, it's important to use standard industry ESD handling precautions. These precautions include using grounded wrist straps, work benches, and floor mats in ESD controlled areas. The ESD sensitivity of the Glenair board mount dual-transmitter is compatible with typical industry production environments.

The second case to consider is static discharges to the exterior of the host equipment after installation, in which case the dual-transmitter may be subject to system-level ESD requirements.

050-316 Product Brief
PC Board Mount Dual-Transmitter
100 Mbps – 5 Gbps, MMF, 3.3V



Application Support

To assist in the dual-transmitter design and evaluation process, Glenair offers the following aids:

- Evaluation board & Product Manual, part number 050-330-MMF-EVALBOARD, which facilitates in the testing of the board mount dual-transmitter.
- 3D Step file to support modeling of mechanical fit and routing
- PADS schematic and PCB layout library files that can be exported into customer's PCB software design program
- Applications Aid Example of PCB layout including details of high speed transmission designs

Customer Manufacturing Processes

This module is mounted with screws and interfaces with a high-speed low cost surface mount electrical connector residing on the host PC board. The board mount dual-transmitter is not designed for aqueous wash, IR reflow, or wave soldering processes and should be mounted on the host board after host PC board has been through its assembly process.

050-316 Product Brief
PC Board Mount Dual-Transmitter
100 Mbps – 5 Gbps, MMF, 3.3V



TABLE 8 TWO-WIRE INTERFACE ID: DATA FIELDS – ADDRESS A0H

Byte Decimal	# Hex	Data Notes	Byte Decimal	# Hex	Data Notes
0	80	Glenair PCB mount Dual Transmitter	37	00	Vendor OUI (NOT USED)
1	04	Serial ID Module Definition	38	00	Vendor OUI (NOT USED)
2	80	"GC" Fiber Optic Connector	39	00	Vendor OUI (NOT USED)
3	00		40	30	"0" Vendor Part Number ASCII character
4	00		41	35	"5" Vendor Part Number ASCII character
5	00		42	30	"0" Vendor Part Number ASCII character
6	01	1000BASE-SX	43	2D	"." Vendor Part Number ASCII character
7	00		44	33	"3" Vendor Part Number ASCII character
8	00		45	31	"1" Vendor Part Number ASCII character
9	00		46	36	"6" Vendor Part Number ASCII character
10	00		47	2D	"." Vendor Part Number ASCII character
11	01	Compatible with 8B/10B encoded data	48	32	"2" Vendor Part Number ASCII character (Note 5)
12	32	BR, 5Gbps	49	20	Note 5
13	00		50	20	"" Vendor Part Number ASCII Character
14	00		51	20	"" Vendor Part Number ASCII Character
15	00		52	20	"" Vendor Part Number ASCII Character
16	37	550m of 50/125mm Fiber @ 1.25Gbps	53	20	"" Vendor Part Number ASCII Character
17	1B	275 m of 62.5/125mm Fiber @ 1.25Gbps (Note 3)	54	20	"" Vendor Part Number ASCII Character
18	00		55	20	"" Vendor Part Number ASCII Character
19	00		56	20	"" Vendor REV Level ASCII Character
20	47	"G" Vendor NAME ASCII Character	57	20	"" Vendor REV Level ASCII Character
21	4C	"L" Vendor NAME ASCII Character	58	20	"" Vendor REV Level ASCII Character
22	45	"E" Vendor NAME ASCII Character	59	20	"" Vendor REV Level ASCII Character
23	4E	"N" Vendor NAME ASCII Character	60	03	Hex Byte of Laser Wavelength (Note 6)
24	41	"A" Vendor NAME ASCII Character	61	52	Hex Byte of Laser Wavelength (Note 6)
25	49	"I" Vendor NAME ASCII Character	62		RESERVED
26	52	"R" Vendor NAME ASCII Character	63		Check sum code for ID fields 0-62 (Note 7)
27	20	"" Vendor NAME ASCII Character	64	00	
28	20	"" Vendor NAME ASCII Character	65	18	Hardware TX_Disable, TX_Fault,
29	20	"" Vendor NAME ASCII Character	66	00	
30	20	"" Vendor NAME ASCII Character	67	00	
31	20	"" Vendor NAME ASCII Character	68-83		Serial Number, ASCII (Note 8)
32	20	"" Vendor NAME ASCII Character	84-91		Date Code (Note 9)
33	20	"" Vendor NAME ASCII Character	92	68	Diagnostic Monitoring Type
34	20	"" Vendor NAME ASCII Character	93	A0	Enhanced Options
35	20	"" Vendor NAME ASCII Character	94	05	SFF-8472 rev 11.0
36	00		95		Checksum for bytes 64-94 (Note 7)
			96-255	00	

Notes:

1. FC-PI speed 100 MBytes/sec is a serial bit rate of 1.0625 GBit/sec.
2. RESERVED
3. Link distance with 62.5/125µm cable at 1.25Gbps is 275m.
4. RESERVED.
5. Table 1, Part number options/extensions
6. Laser wavelength is represented in 16 unsigned bits. The hex representation of 850nm is 0352.
7. Addresses 63 and 95 are checksums calculated per SFF-8472 and SFF-8074, and stored prior to product shipment.
8. Addresses 68-83 specify the module's ASCII serial number and will vary by unit.
9. Addresses 84-91 specify the module's ASCII date code and will vary according to manufactured date-code.

050-316 Product Brief
PC Board Mount Dual-Transmitter
100 Mbps – 5 Gbps, MMF, 3.3V



Table 9 Two-Wire interface ID: Data Fields – Address A2h

Byte # Decimal	Data Notes	Byte # Decimal	Data Notes	Byte # Decimal	Data Notes
0	Temp H Alarm MSB (Note 1)	26	TX Pwr L Alarm MSB (Note 4)	104	Reserved
1	Temp H Alarm LSB (Note 1)	27	TX Pwr L Alarm LSB (Note 4)	105	Reserved
2	Temp L Alarm MSB (Note 1)	28	TX Pwr H Warning MSB (Note 4)	106	Reserved
3	Temp L Alarm LSB (Note 1)	29	TX Pwr H Warning LSB (Note 4)	107	Reserved
4	Temp H Warning MSB (Note 1)	30	TX Pwr L Warning MSB (Note 4)	108	Reserved
5	Temp H Warning LSB (Note 1)	31	TX Pwr L Warning LSB (Note 4)	109	Reserved
6	Temp L Warning MSB (Note 1)	32	Reserved	110	Status/Control
7	Temp L Warning LSB (Note 1)	33	Reserved	111	Reserved
8	Vcc H Alarm MSB (Note 2)	34	Reserved	112	Flag Bits
9	Vcc H Alarm LSB (Note 2)	35	Reserved	113	Flag Bits
10	Vcc L Alarm MSB (Note 2)	36	Reserved	114	Reserved
11	Vcc L Alarm LSB (Note 2)	37	Reserved	115	Reserved
12	Vcc H Warning MSB (Note 2)	38	Reserved	116	Flag Bits
13	Vcc H Warning LSB (Note 2)	39	Reserved	117	Flag Bits
14	Vcc L Warning MSB (Note 2)	40-45	Reserved	118	Reserved
15	Vcc L Warning LSB (Note 2)	56-94	External Cal Constants (Note 6)	119	Reserved
16	Tx Bias H Alarm MSB (Note 3)	95	Checksum for bytes 0-94	120-122	Reserved
17	Tx Bias H Alarm LSB (Note 3)	96	Temperature MSB (Note 1)	123	Reserved
18	Tx Bias L Alarm MSB (Note 3)	97	Temperature LSB (Note 1)	124	Reserved
19	Tx Bias L Alarm LSB (Note 3)	98	Vcc MSB (Note 2)	125	Reserved
20	Tx Bias H Warning MSB (Note 3)	99	Vcc LSB (Note 2)	126	Reserved
21	Tx Bias H Warning LSB (Note 3)	100	TX Bias MSB (Note 3)	127	Reserved (Note 8)
22	Tx Bias L Warning MSB (Note 3)	101	TX Bias LSB (Note 3)	128-247	Customer Writable (Note 9)
23	Tx Bias L Warning LSB (Note 3)	102	TX Power MSB (Note 4)	248-255	Vendor Specific
24	TX Pwr H Alarm MSB (Note 4)	103	TX Power LSB (Note 4)		
25	TX Pwr H Alarm LSB (Note 4)				

Notes:

1. Temperature (Temp) is decoded as a 16 bit signed twos complement integer in increments of 1/256 °C.
2. Supply voltage (VCC) is decoded as a 16 bit unsigned integer in increments of 100 µV.
3. Laser bias current (Tx Bias) is decoded as a 16 bit unsigned integer in increments of 2 µA.
4. Transmitted average optical power (Tx Pwr) is decoded as a 16 bit unsigned integer in increments of 0.1 µW.
5. Reserved
6. Bytes 56-94 are not intended from use but have been set to default values per SFF-8472.
7. Bytes 95 is a checksum calculated (per SFF-8472) and stored prior to product shipment.
8. Byte 127 accepts a write but performs no action (reserved legacy byte).
9. Bytes 128-247 are write enabled (customer writable).

050-316 Product Brief
PC Board Mount Dual-Transmitter
100 Mbps – 5 Gbps, MMF, 3.3V



TABLE 10 **TRANSCEIVER DIGITAL DIAGNOSTIC MONITOR CHARACTERISTICS (WHEN APPLICABLE)**

PARAMETER	SYMBOL	MIN.	UNITS	NOTES
Dual Transmitter Internal Temperature Accuracy	TINT	±3.0	°C	Temperature is measured internal to the Dual Transmitter and is valid from -40°C to +85 °C case temperature
Dual Transmitter internal Supply Voltage accuracy	VINT	±0.1	V	Supply voltage is measured internal to the Dual Transmitter and can, with less accuracy, be correlated to the voltage at the Vcc pin. Valid over 3.3V ±5%
Dual Transmitter Laser DC Bias Current Accuracy	IINT	±10	%	
Dual Transmitter Average Optical Output Power Accuracy	PT	±3.0	dB	Coupled into 50/125 mm MM fiber. Valid from -1dBm to -10dBm

050-316 Product Brief
PC Board Mount Dual-Transmitter
100 Mbps – 5 Gbps, MMF, 3.3V



ACCESSORIES

Fiber Optic Jumper Cables to support connection to Mil/Aerospace Connectors

KEY FEATURES:

- Jumper cable between Glenair Dual-transmitter (end A) and Mil/Aero Connector termini (End B)
- Offered with either Multimode and Single Mode fibers

FIGURE 6
Fiber Optic Jumper Cable Assembly (see separate Glenair sales drawing FA02454 for details)

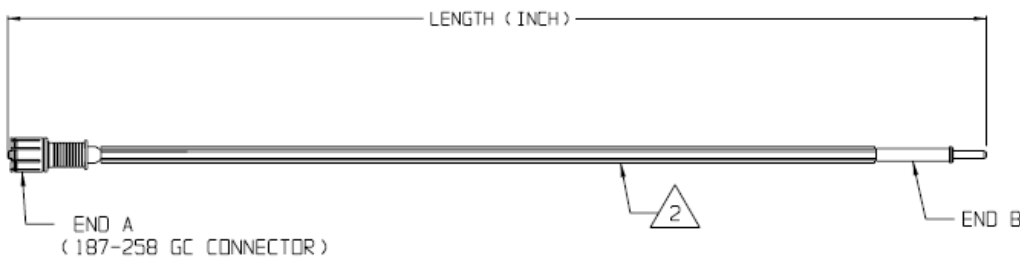

PCB Threaded Inserts, PN 059-0007

KEY FEATURES

- Simplifies installation of board mount dual-transmitters eliminating the need for washers and nuts
- Soldered to PCB to eliminate need for handling nuts during assembly
- Existing Options to support PCB thickness from 0.03" to 0.92"
- Can support thicker PCB if required

EVALUATION Boards, PN 050-330, Include

- MANUAL with test block diagram, schematic and Evaluation board PCBA
- Multiple types of board mount Dual-transmitter modules supported by this evaluation board
- 2 fiber optic cables (~1m, GC connector to LC connector)

