



# Performance Specifications

Supply Voltage (Vs)						
Parameter	Min	Typical	Max	Units	Condition	
Supply voltage (standard)	14.25	15	15.75	VDC	@ Vsnom & 25°C @ Vsnom	
Current consumption steady state			200	mA		
Current consumption during warm up			550	mA		
Warm up time			3	min	@ 25°C to final frequency	
RF Output						
Signal [standard]	Sinewave				50 Ω load	
Load	45	50	55	Ohm		
Output Power	7	10	13	dBm	50 Ω load <sup>3</sup>	
Output Power	10	13	16	dBm	optional 50 Ω load <sup>3</sup>	
Harmonics			-30	dBc	50 Ω load	
Spurious			-80	dBc	50 Ω load	
Frequency Tuning (EFC)						
Absolute Pulling Range	±0.0			ppm	Pulling range is sufficient to tune the oscillator over lifetime of 10 years and all circumstances to nominal frequency	
Tuning Slope	Positive					
Control Voltage Range	-4	0	+4	VDC		
Frequency control input impedance	50			kOhm		
Additional Parameters						
Phase Noise <sup>2</sup>		-95		dBc/Hz	10 Hz	@ 120 MHz 10 dBm sinewave no vibration <sup>3</sup>
		-125		dBc/Hz	100 Hz	
		-150		dBc/Hz	1 kHz	
		-163		dBc/Hz	10 kHz	
		-170		dBc/Hz	100 kHz	
Phase Noise <sup>2</sup>		-170		dBc/Hz	1 MHz	optional @ 120 MHz 13 dBm sinewave no vibration <sup>3</sup>
		-103		dBc/Hz	10 Hz	
		-134		dBc/Hz	100 Hz	
		-158		dBc/Hz	1 kHz	
		-169		dBc/Hz	10 kHz	
	-174		dBc/Hz	100 kHz		
	-174		dBc/Hz	1 MHz		
G-Sensitivity		0.5		ppb/g	without shock absorbers <sup>3</sup>	
G-Sensitivity			1	ppb/g	optional without shock absorbers <sup>3</sup>	
G-Sensitivity			0.5	ppb/g	optional without shock absorbers <sup>3</sup>	
Weight		55	75	g		
Processing & Packing	Handling & Processing Note					
Additional Environmental Conditions						
Random Vibration	RTCA/DO-160 D, Section 8, Category R or R2 curve C and C1					
Shock	MIL-STD-202G; Method 213B; 15 g / 20 ms				for softest shock absorber i.e. lowest resonance frequency	
Solderability	JEDEC J-STD-002 non RoHS compliant					
Solvent Resistance	non-washable device					
Absolute Maximum Ratings						
Supply voltage (Vs)			16.0	V		
Output Load	45		55	Ω		
Operable Temperature Range	-40		+85	°C		
Storage Temperature Range	-55		+105	°C		

# Outline Drawing / Enclosure

Parameter	Min	Typical	Max	Units	Condition
G295 including vibration isolators. Mechanical resonance frequency	35		110	Hz	Please specify vibration profile and phase noise max values under vibration

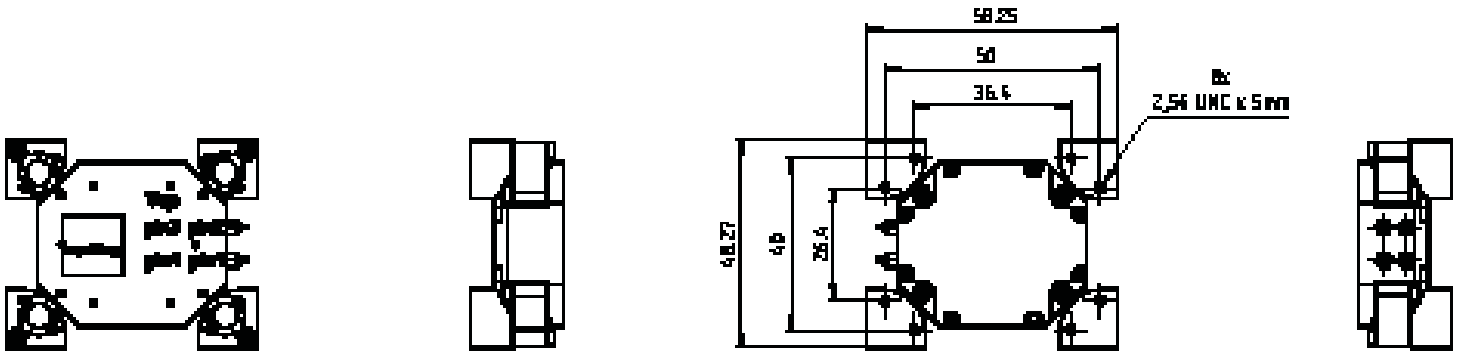
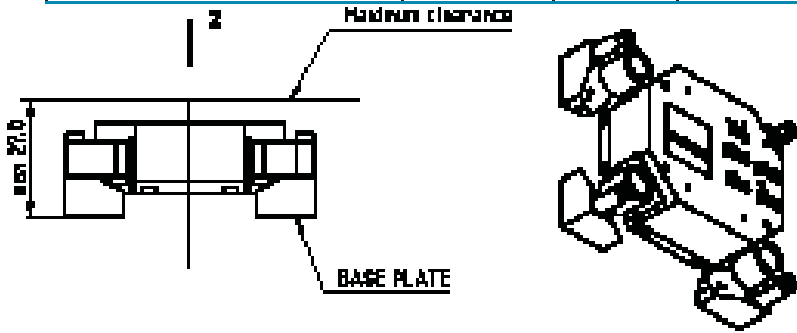

Parameter	Min	Typical	Max	Units	Condition
G313 without vibration isolators.					Option please specify vibration profile and phase noise max values under vibration

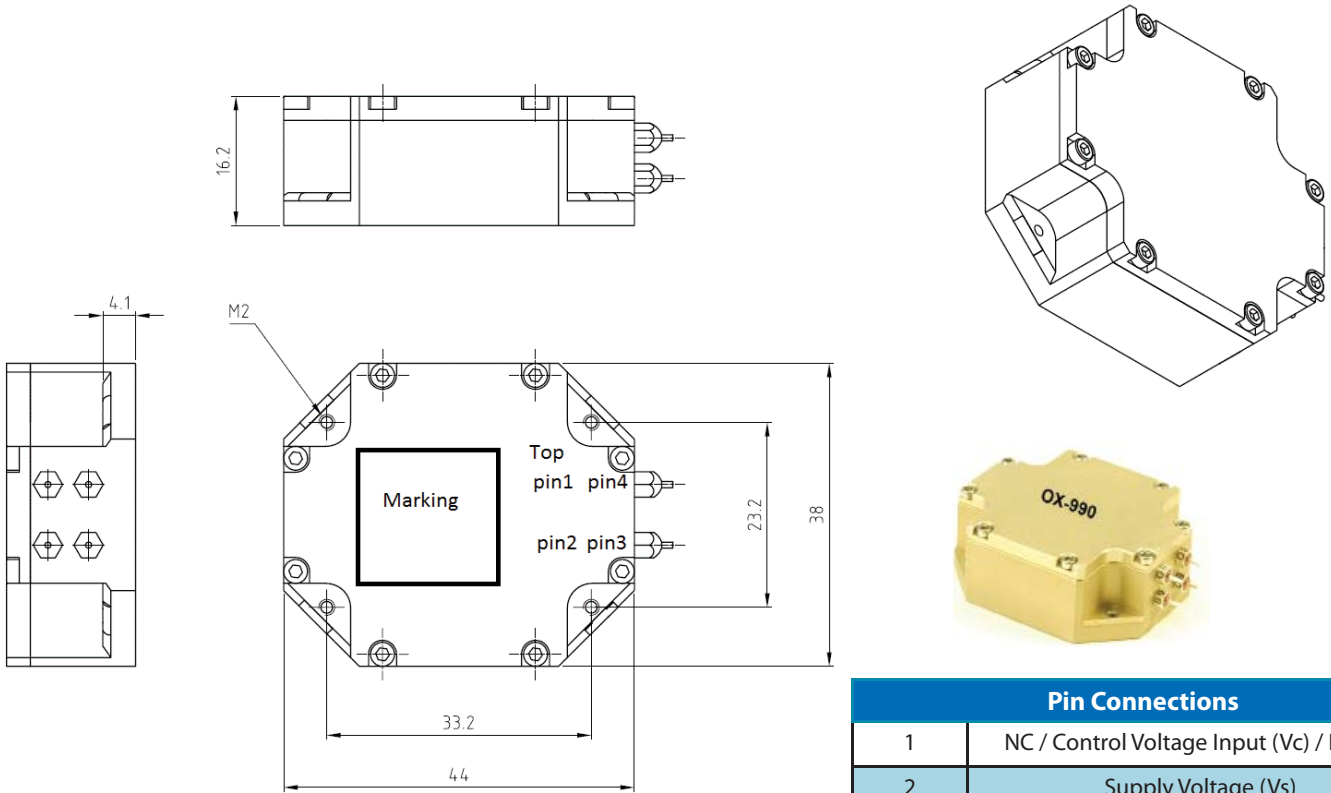

Dimensions in mm

Pin Connections	
1	NC / Control Voltage Input (Vc) / Enable
2	Supply Voltage (Vs)
3	RF-Output
4	Ground (Case)

# Typical Phase Noise @ 120 MHz 10 dBm without vibration

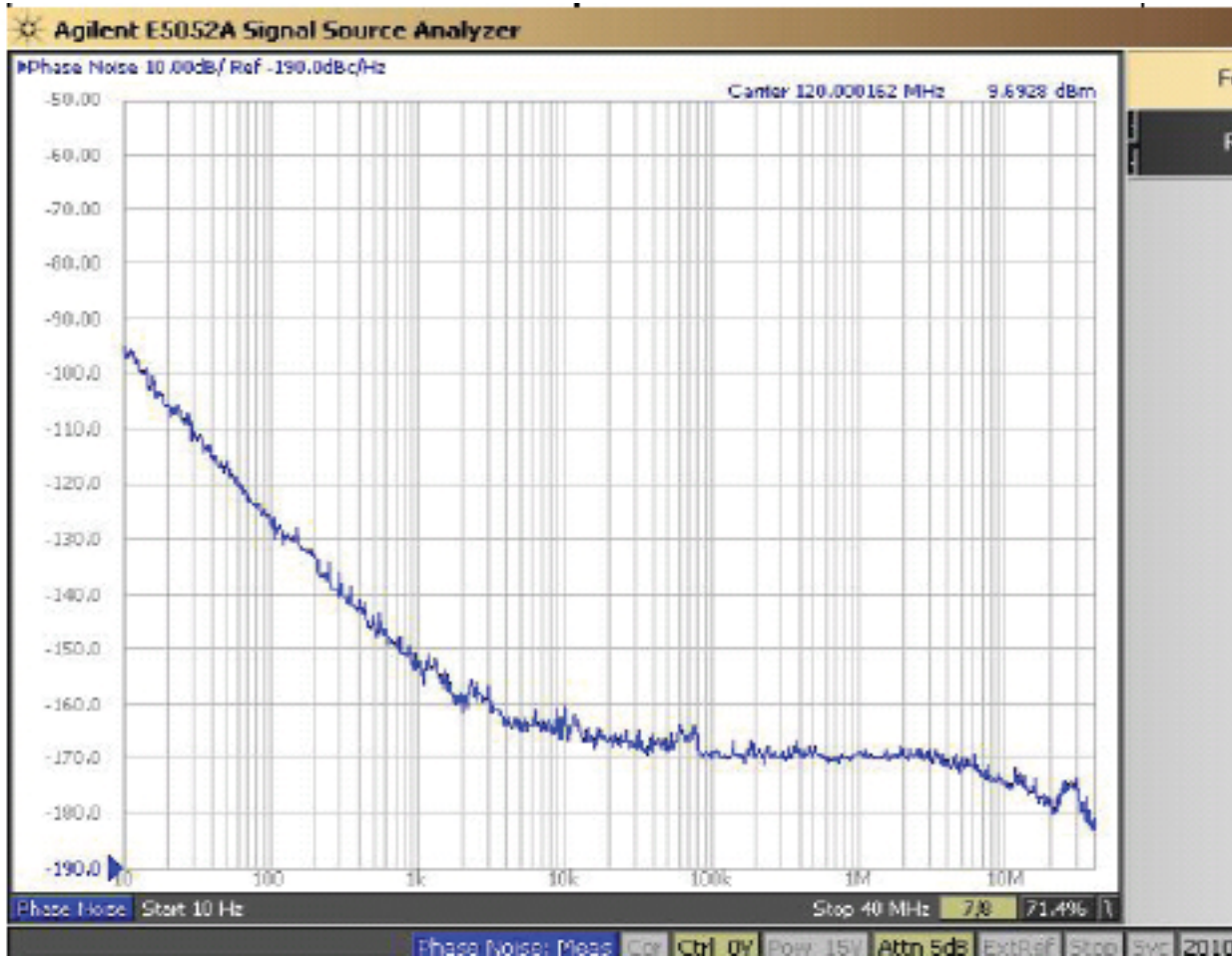

# Typical Phase Noise @ 120 MHz, with optional 13 dBm, without vibration

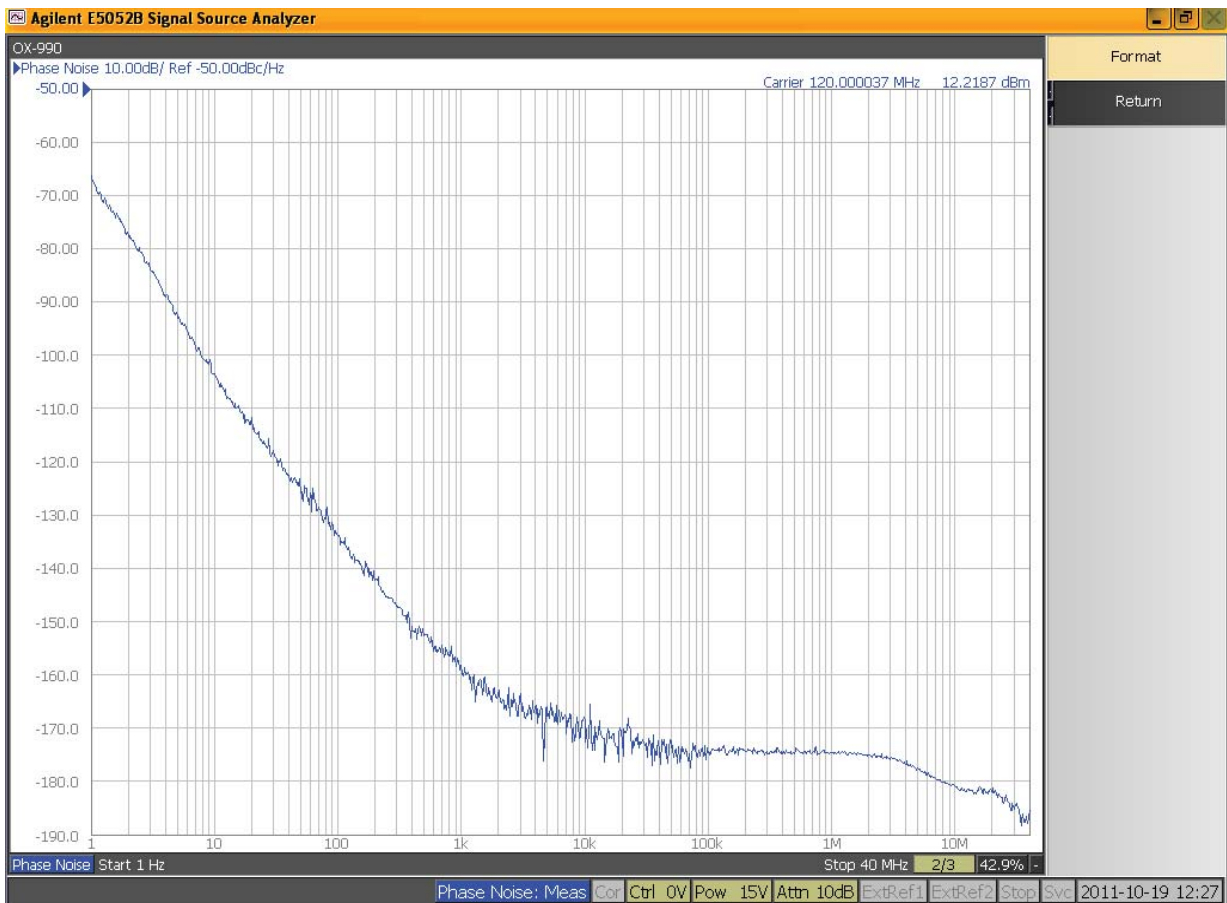

# Typical G-Sensitivity @120 MHz without shock absorber

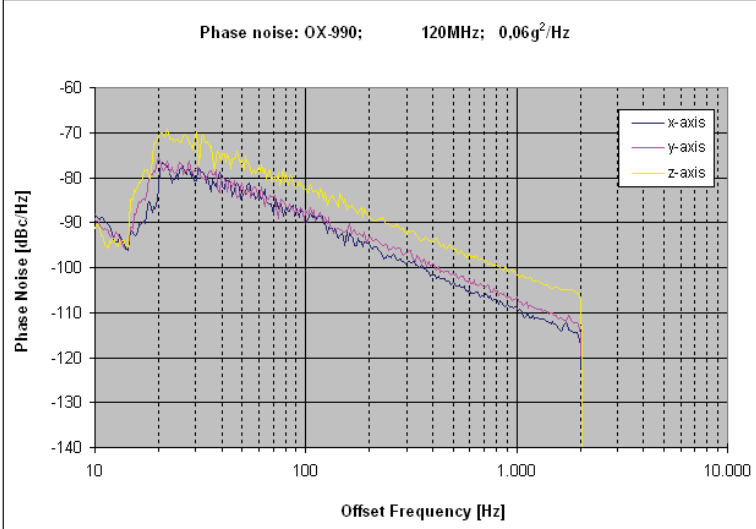
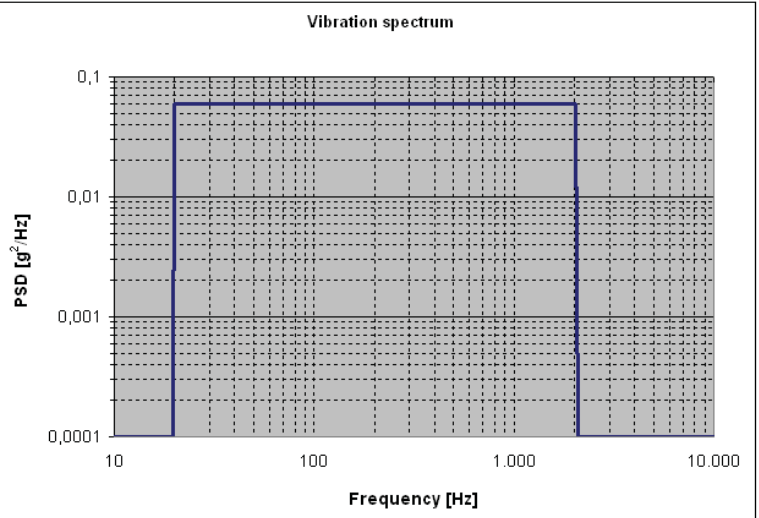
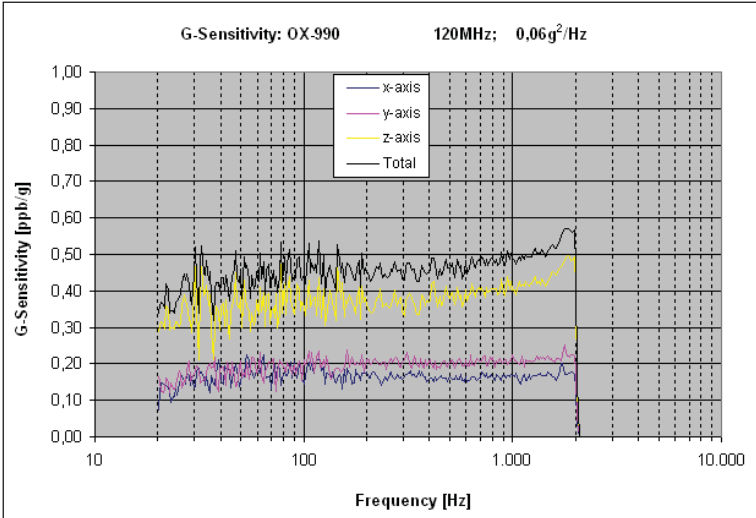

Calculation equation according to Vig-Tutorial

g-sensitivity: 
$$G = \frac{2 \cdot f_v}{A_{peak} \cdot f_0} \cdot 10^{\frac{L(f_v)}{20}}$$

Peak g-level: 
$$A_{peak} = \sqrt{PSD \cdot 2}$$

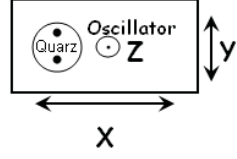

Comments:  
Measured without shock absorbers



# Typical Frequency Stability vs Temperature @ 10 dBm -40..+70°C



## Frequency vs. Temperature

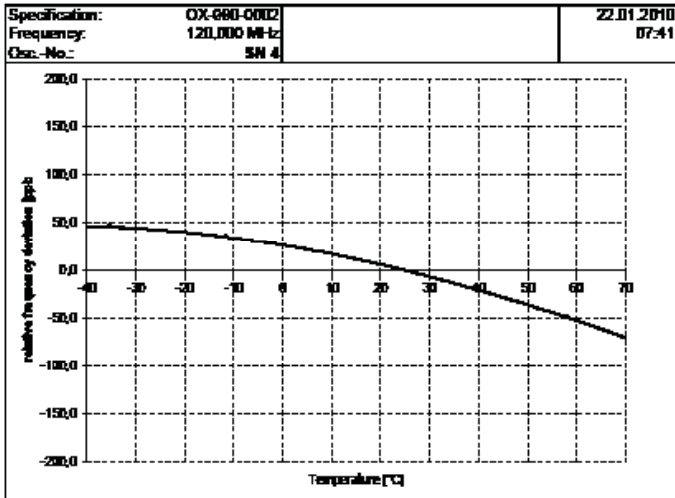

## Pout vs. Temperature

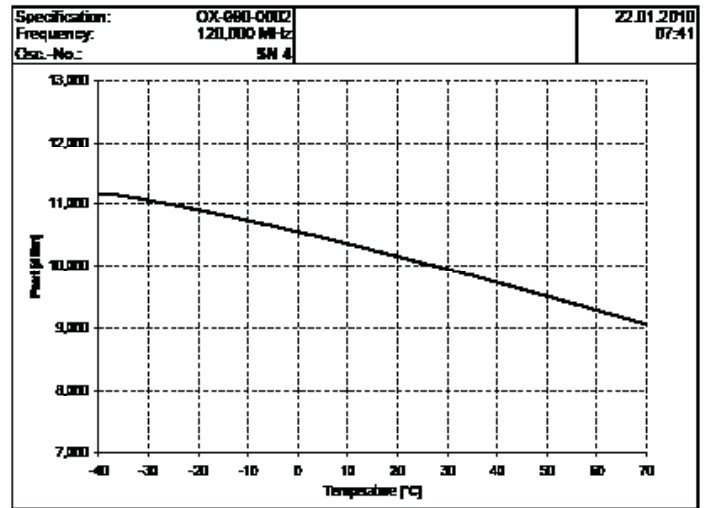

# Typical Frequency Stability vs Temperature @ 13 dBm -40..+85°C optional



## Frequency vs. Temperature

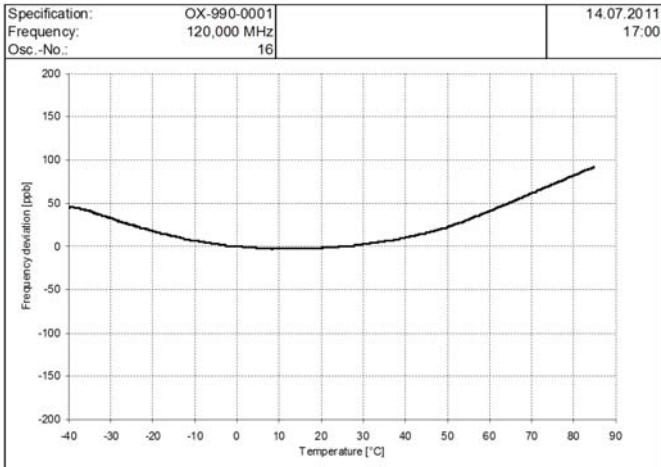

## Pout vs. Temperature

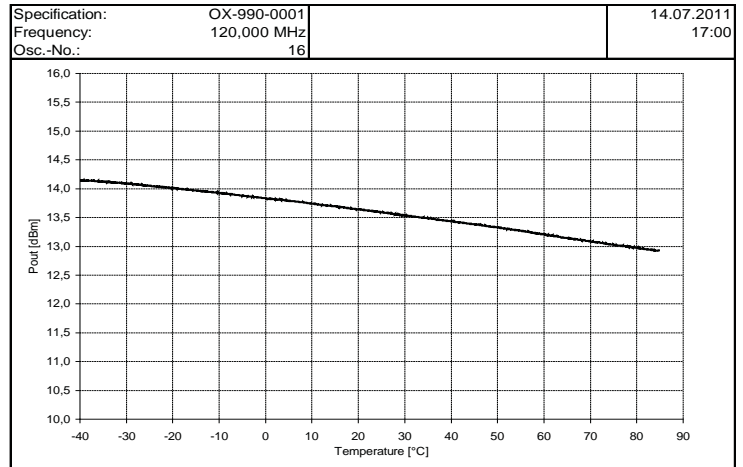

# Typical Phase Noise @ 120 MHz with vibration

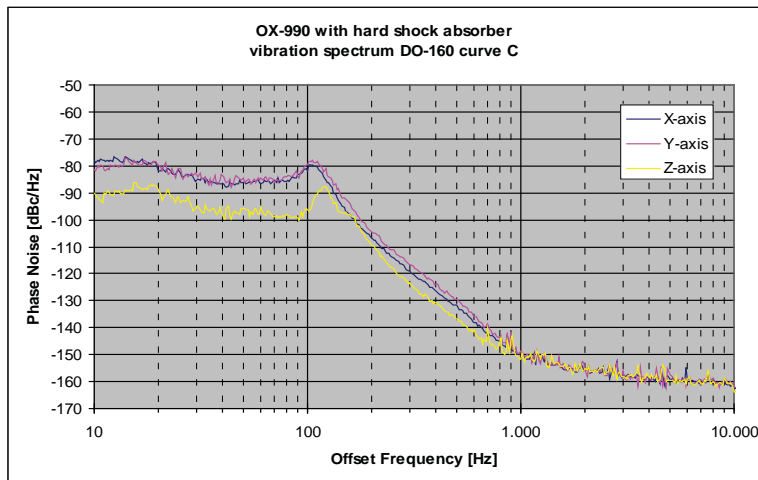
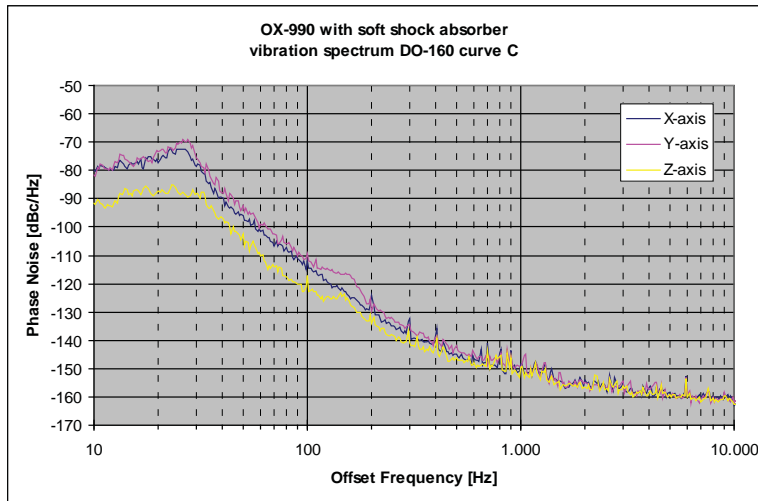
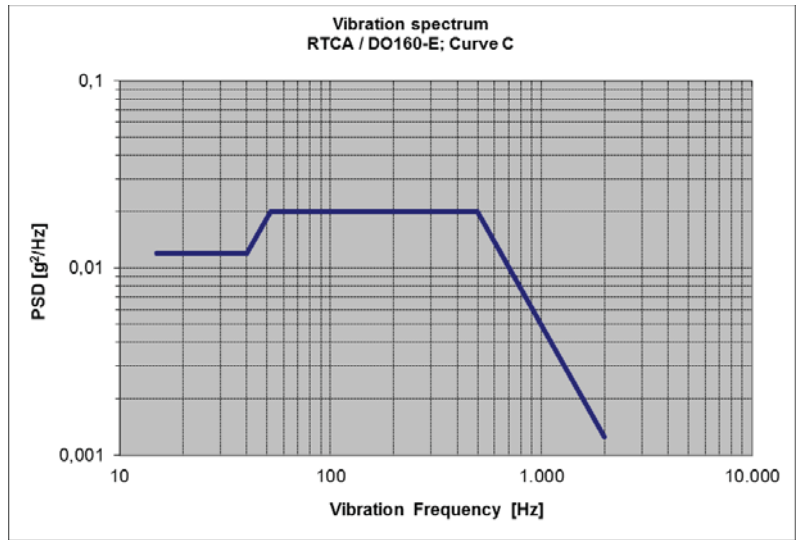
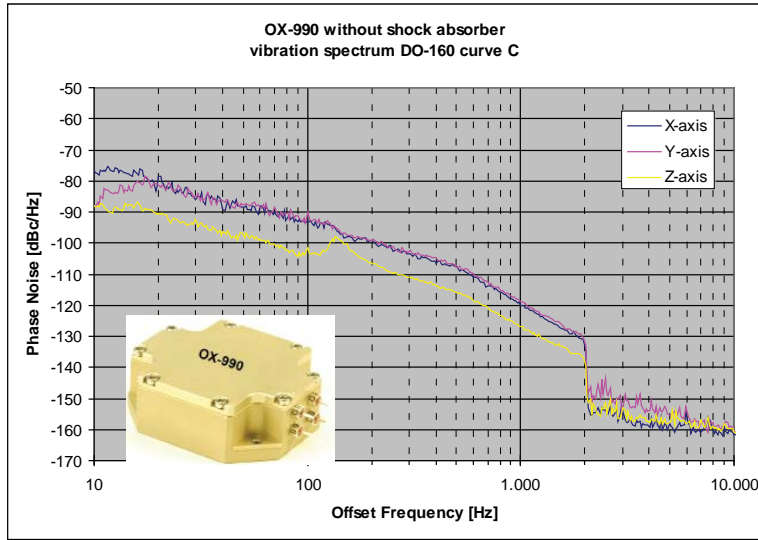

## Ordering Information

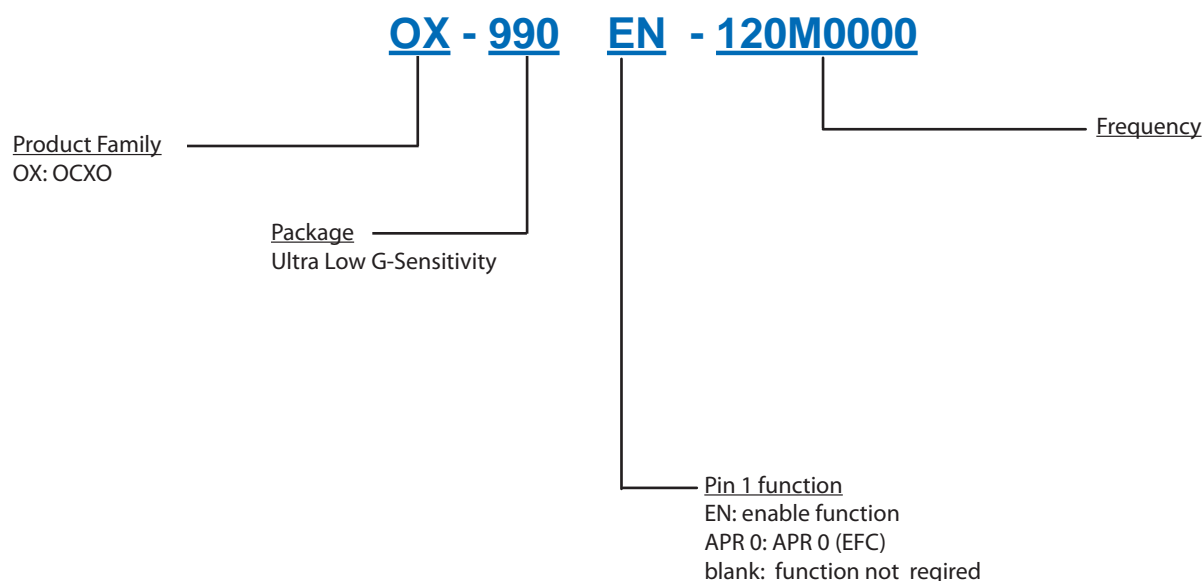

### Notes:

1. Contact factory for improved stabilities or additional product options. Not all options and codes are available at all frequencies.
2. Phase noise degrades with increasing output frequency.
3. Contact factory for availability.

Unless other stated all values are valid after warm-up time and refer to typical conditions for supply voltage, frequency control voltage, load, temperature (25°C).

Subject to technical modification.

## For Additional Information, Please Contact

### USA:

Vectron International  
267 Lowell Road, Suite 102  
Hudson, NH 03051  
Tel: 1.888.328.7661  
Fax: 1.888.329.8328

### Europe:

Vectron International  
Landstrasse, D-74924  
Neckarbischofsheim, Germany  
Tel: +49 (0) 7268.801.100  
Fax: +49 (0) 7268.801.282

### Asia:

Vectron International  
68 Yin Cheng Road(C), 22nd Floor,  
One LuJiaZui  
Pudong, Shanghai 200120, China  
Tel: 86.21.6194.6886  
Fax: 86.21.6194.6699

### Disclaimer

Vectron International reserves the right to make changes to the product(s) and or information contained herein without notice. No liability is assumed as a result of their use or application. No rights under any patent accompany the sale of any such product(s) or information.

Rev: 02/2014