

GHz BGA Socket - Direct mount, solderless

Top View

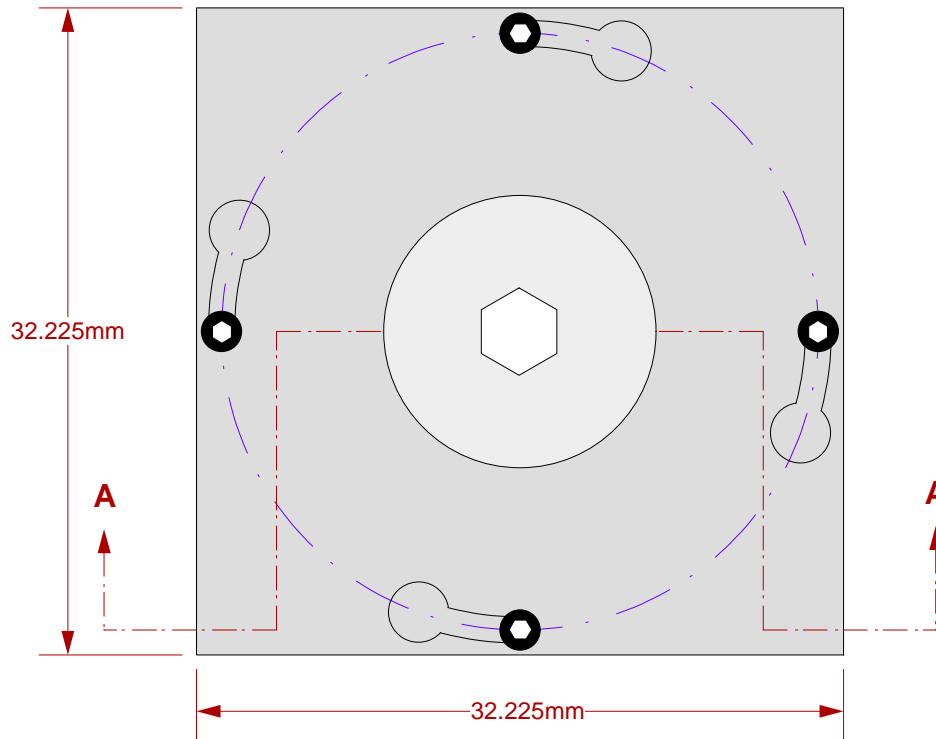

Features

- Directly mounts to target PCB (needs tooling holes) with hardware.
- High speed, reliable Elastomer connection
- Minimum real estate required
- Compression plate distributes forces evenly
- Ball guide prevents over compression of elastomer
- Easily removable swivel socket lid

- △ 1 Socket Lid: Black anodized Aluminum. Thickness = 2.5mm.
- △ 2 Socket base: Black anodized Aluminum. Thickness = 6mm.
- △ 3 Compression Plate: Black anodized Aluminum. Thickness = 2.5mm.
- △ 4 Compression screw: Clear anodized Aluminum. Thickness = 5mm, Hex socket = 5mm.
- △ 5 Elastomer: 40 micron dia gold plated brass filaments arranged symmetrically in a silicone rubber (63.5 degree angle). Thickness = 0.75mm.
- △ 6 Elastomer Guide: Non-clad FR4. Thickness = 0.75mm.
- △ 7 Ball Guide: Kapton polyimide.
- △ 8 Socket base screw: Fillister head, Alloy steel with black oxide finish, 0-80 fine thread, 12.7mm long.
- △ 9 Socket lid screw: Shoulder screw, 18-8 SS, 0-80 fine thread.
- △ 10 Insulation Plate: FR4/G10, 1.59mm thick.
- △ 11 Backing Plate: Anodized Aluminum 6.35mm thick.
- △ 12 IC Frame: Ultem 1000.

Recommended torque = 9 in lbs./
144 in oz.

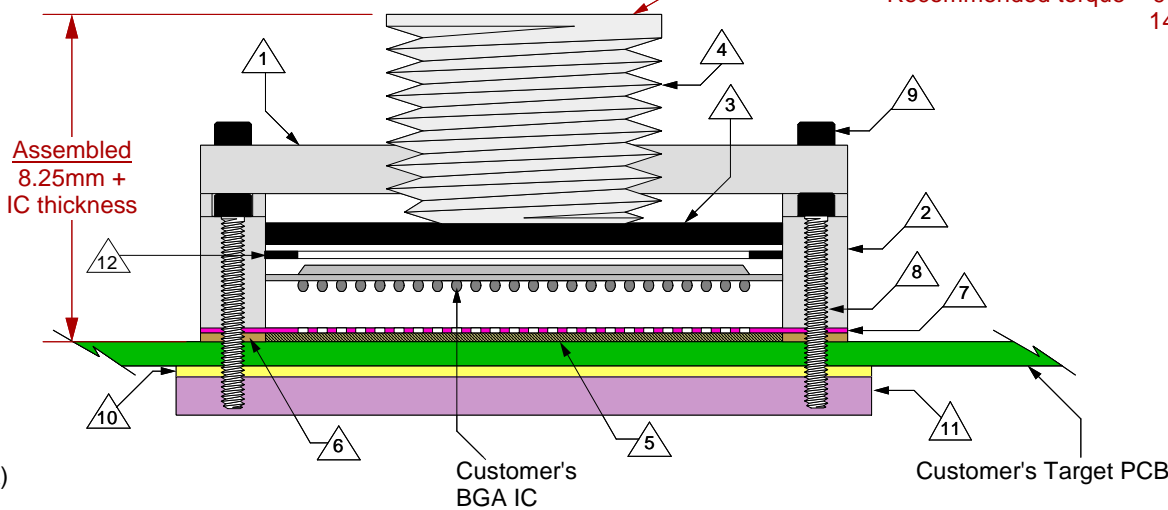

Side View
(Section AA)

SG-BGA-6107 Drawing

© 2009 IRONWOOD ELECTRONICS, INC.
11351 Rupp Drive, Suite 400, Burnsville, MN 55337
Tele: (952) 229-8200
www.ironwoodelectronics.com

Status: Released

Scale: -

Rev: D

Drawing: H. Hansen

Date: 4/9/04

File: SG-BGA-6107 Dwg

Modified: 7/21/09, AE

All tolerances: $\pm 0.125\text{mm}$ (unless stated otherwise). Materials and specifications are subject to change without notice.

Recommended PCB Layout
Top View

Note: Full BGA pattern shown.
 Please adjust pattern according
 to individual requirements.

***Note: BGA pattern is not symmetrical
 with respect to the mounting holes.**

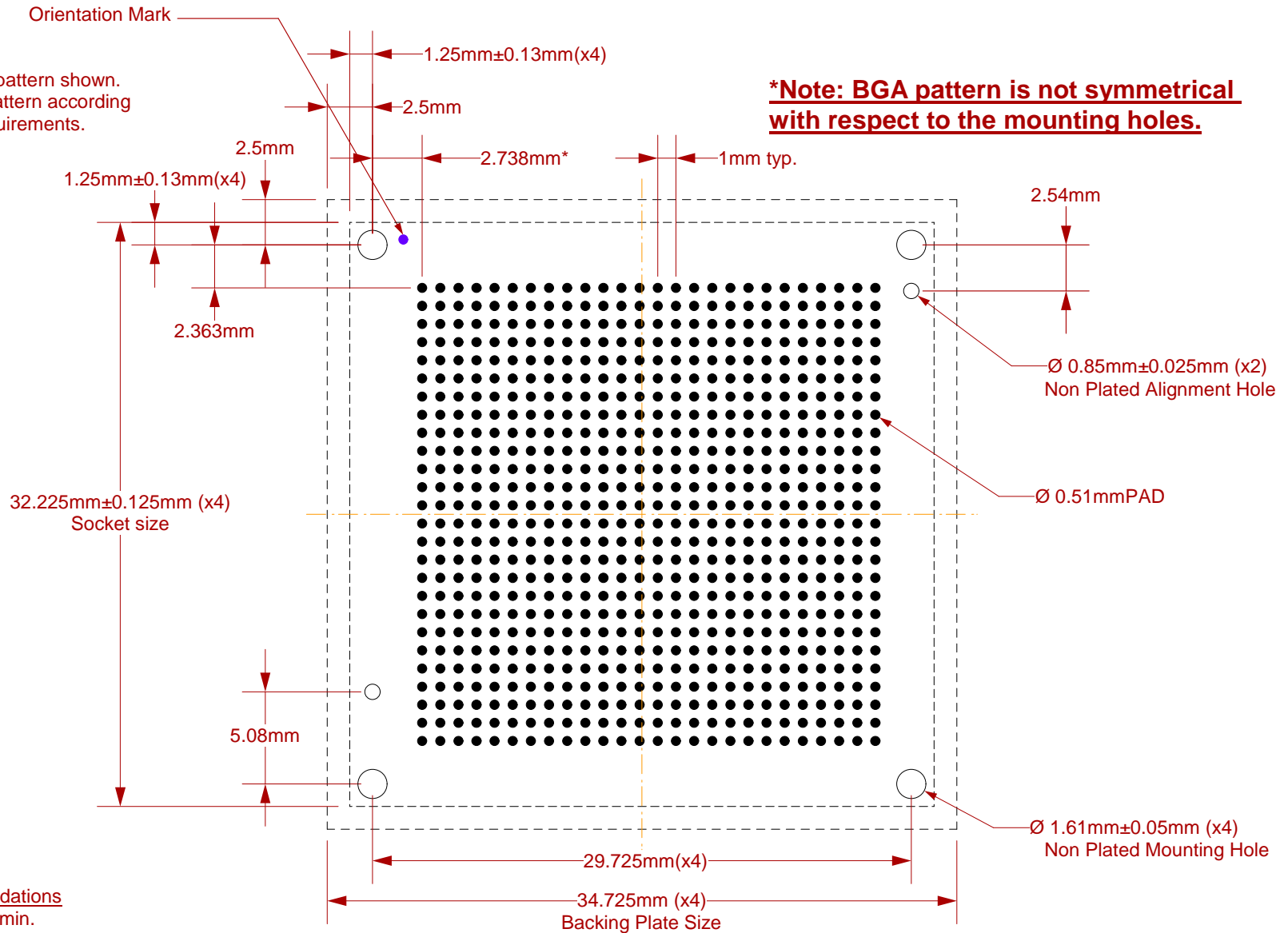

Target PCB Recommendations

Total thickness: 1.6mm min.
 Plating: Gold or Solder finish
 PCB Pad height: Same or higher than solder mask

NOTE: Steel backing plate may be required based on end user's application

Recommended PCB Layout Tolerances: $\pm 0.025\text{mm}$ [$\pm 0.001''$] unless stated otherwise.

 <p>© 2009 IRONWOOD ELECTRONICS, INC. 11351 Rupp Drive, Suite 400, Burnsville, MN 55337 Tele: (952) 229-8200 www.ironwoodelectronics.com</p>	SG-BGA-6107 Drawing		Status: Released	Scale: 3:1	Rev: D
	Drawing: H. Hansen		Date: 4/9/04		
	File: SG-BGA-6107 Dwg		Modified: 7/21/09, AE		

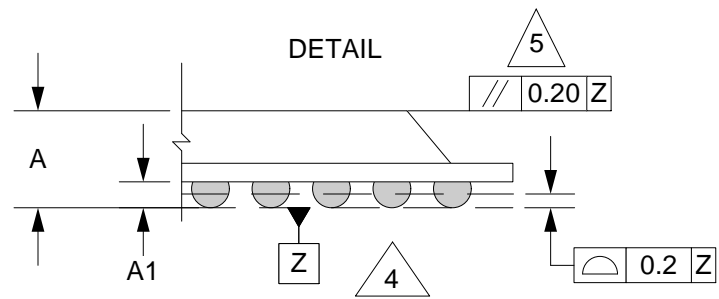
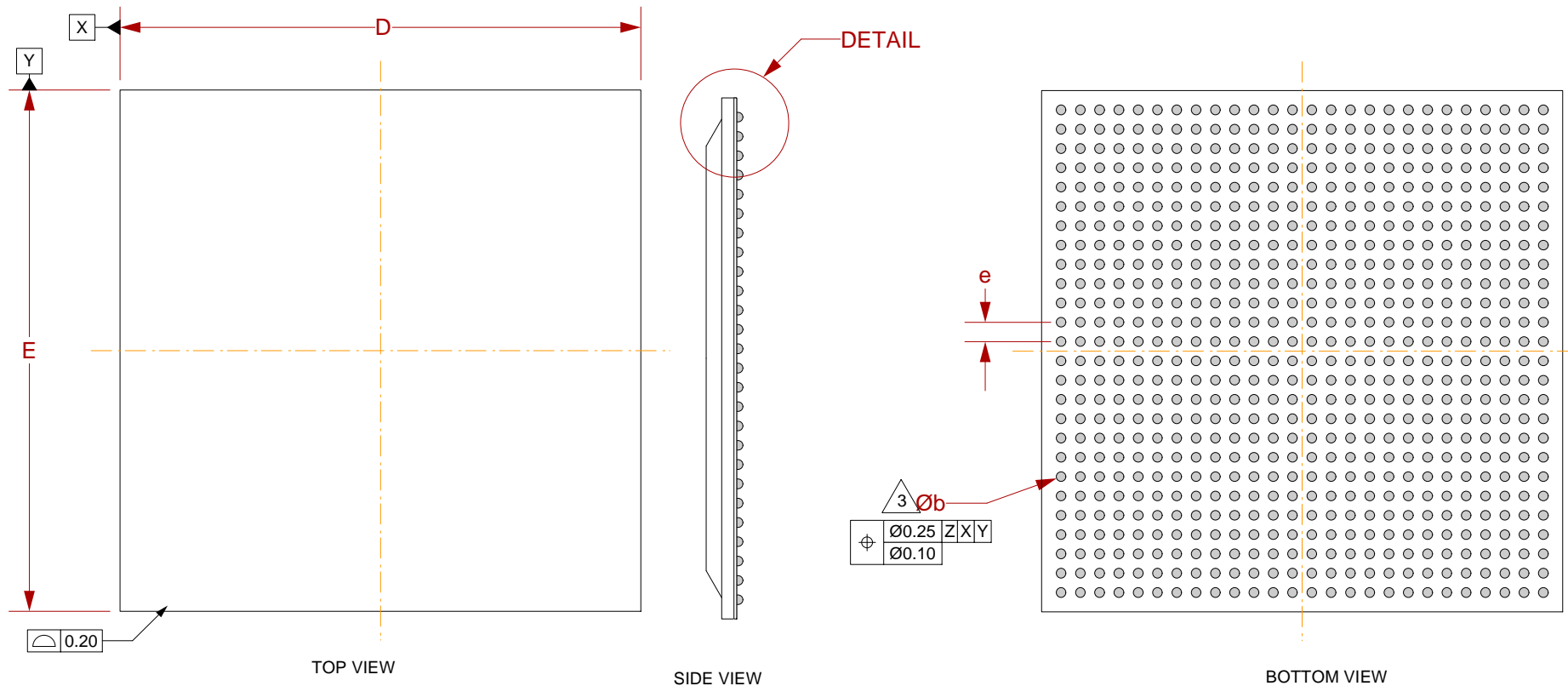

1. Dimensions are in millimeters.
 2. Interpret dimensions and tolerances per ASME Y14.5M-1994.
- 3. Dimension b is measured at the maximum solder ball diameter, parallel to datum plane Z.
 - 4. Datum Z (seating plane) is defined by the spherical crowns of the solder balls.
 - 5. Parallelism measurement shall exclude any effect of mark on top surface of package.

DIM	MIN	MAX
A		2.85
A1	0.4	0.6
b		0.70
D	27.00 BSC	
E	27.00 BSC	
e	1.0 BSC	

Array 26x26

 <p>SG-BGA-6107 Drawing</p> <p>© 2009 IRONWOOD ELECTRONICS, INC. 11351 Rupp Drive, Suite 400, Burnsville, MN 55337 Tele: (952) 229-8200 www.ironwoodelectronics.com</p>	Status: Released	Scale: -	Rev: D
	Drawing: H. Hansen		Date: 4/9/04
	File: SG-BGA-6107 Dwg		Modified: 7/21/09, AE

Top View

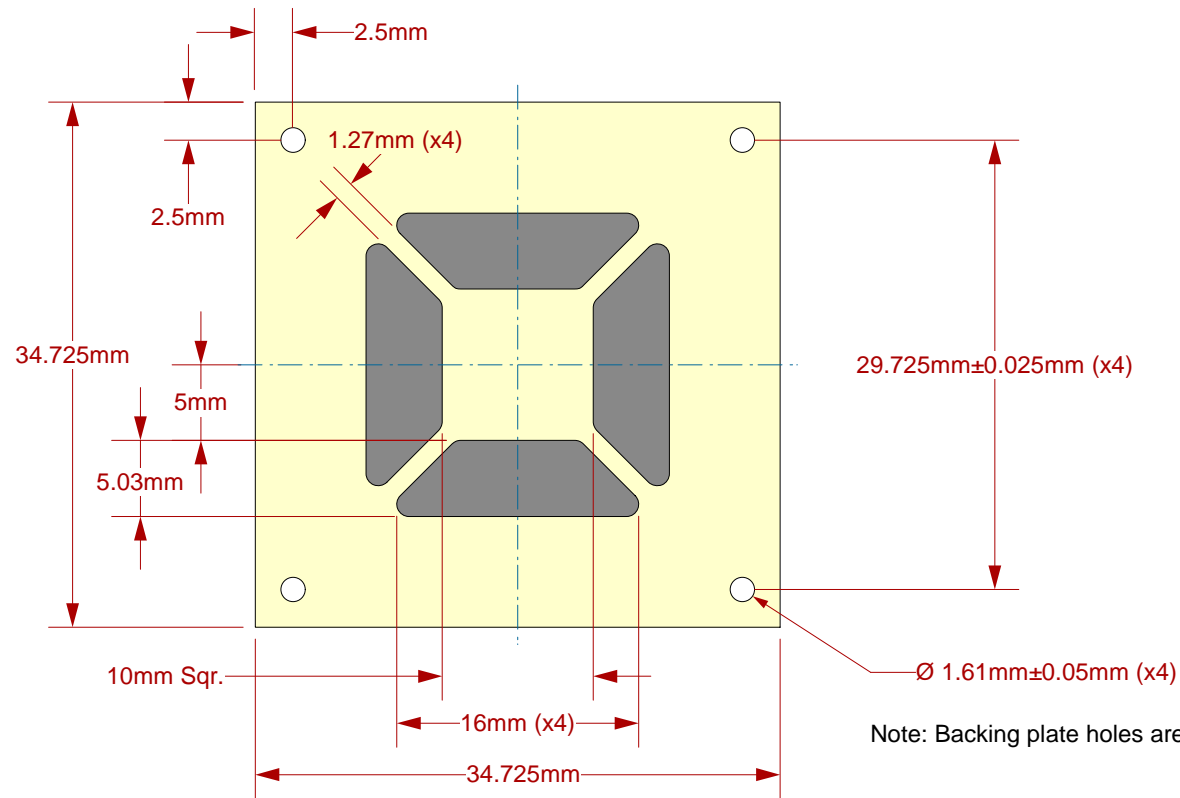

Note: Backing plate holes are tapped to accept 0-80 screws.

Side View

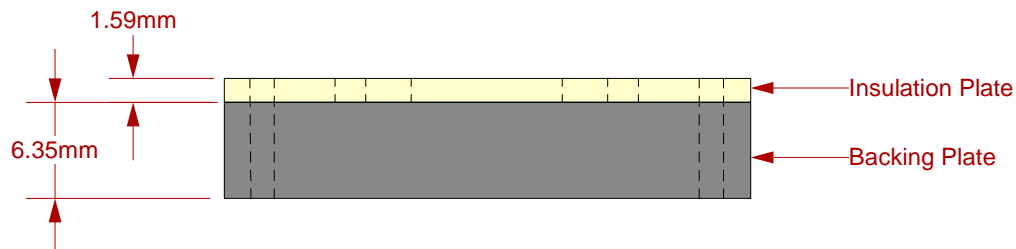

Description: Backing Plate with Insulation Plate

	SG-BGA-6107 Drawing		Status: Released	Scale: -	Rev: D
	© 2009 IRONWOOD ELECTRONICS, INC. 11351 Rupp Drive, Suite 400, Burnsville, MN 55337 Tele: (952) 229-8200 www.ironwoodelectronics.com		Drawing: H. Hansen		Date: 4/9/04
				File: SG-BGA-6107 Dwg	Modified: 7/21/09, AE

All dimensions are in mm.
 All tolerances are +/- 0.125mm.
 (Unless stated otherwise)