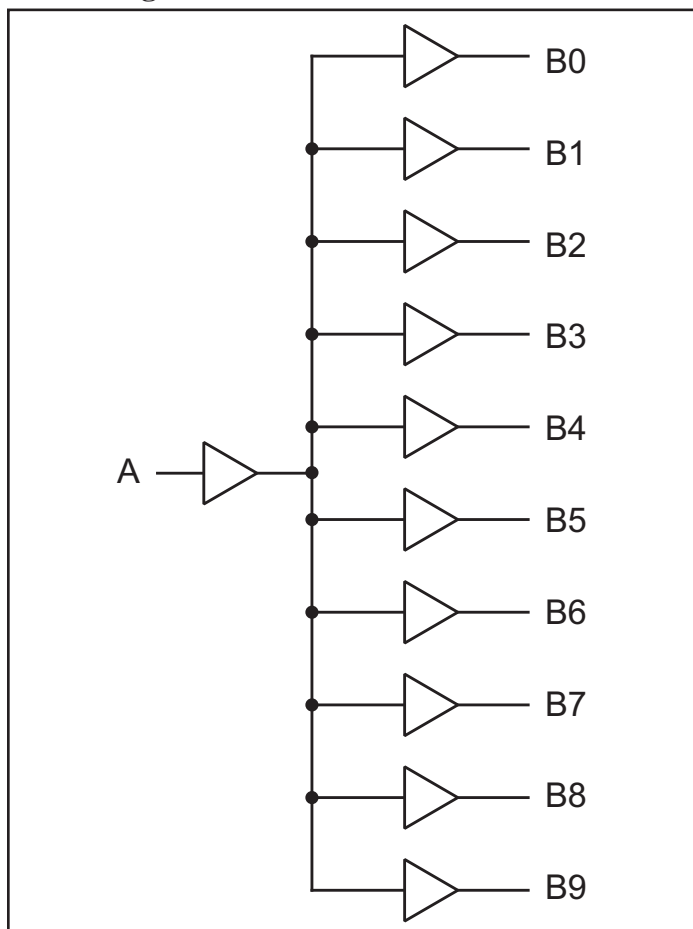
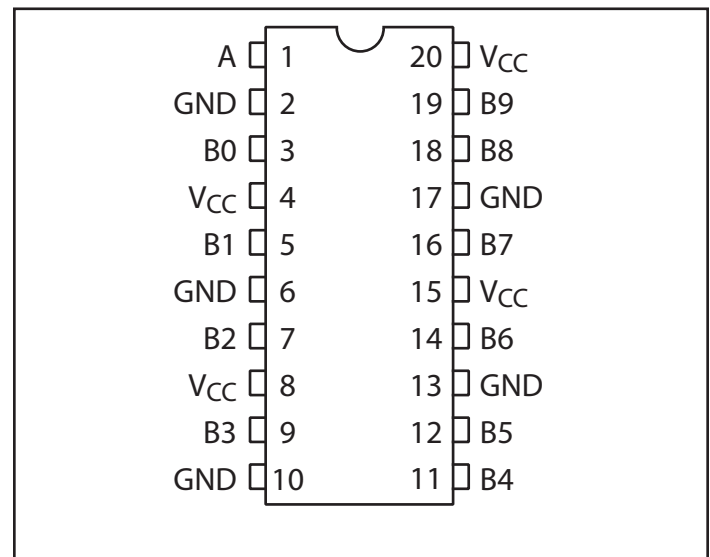

**3.3V Fast CMOS Clock Driver**
**Features**

- 3.3V version of PI49FCT807
- Ultra low skew: 0.35ns
- Low Input Capacitance
- Minimum duty cycle distortion
- 1:10 fanout
- High speed: 3.5ns propagation
- TTL input and CMOS output compatible
  - VOH =3.3V (typical)
  - VOL =0.3V (typical)
- Industrial Temperature: -40°C to +85°C
- 3.3V ±10% operation
- Packaging (Pb-free & Green Available):
  - 20-pin 300-mil wide SOIC (S)
  - 20-pin 150-mil wide QSOP (Q)
  - 20-pin 209-mil wide SSOP (H)

**Description**

Pericom Semiconductor's PI49FCT3807 is a 3.3V 1-to-10 clock driver. This low skew clock driver features one input and ten outputs fanout. The large fanout from a single input line reduced loading on input clock. TTL level outputs reduce noise levels on the part. Typical applications are clock and signal distribution

**Block Diagram**

**Pin Configuration**

**Pin Description**

Pin Name	Description
A	Input
B <sub>0</sub> -B <sub>9</sub>	Outputs
GND	Ground
VCC	Power

### Maximum Ratings

(Above which the useful life may be impaired. For user guidelines, not tested.)

Storage Temperature .....	-65°C to +150°C
Ambient Temperature with Power Applied .....	-40°C to +85°C
Supply Voltage to Ground Potential (Inputs & V <sub>CC</sub> Only).....	-0.5V to +7.0V
Supply Voltage to Ground Potential (Outputs & D/O Only) ..	-0.5V to +7.0V
DC Input Voltage .....	-0.5V to +7.0V
DC Output Current.....	120mA
Power Dissipation .....	0.5W

**Note:**

Stresses greater than those listed under MAXIMUM RATINGS may cause permanent damage to the device. This is a stress rating only and functional operation of the device at these or any other conditions above those indicated in the operational sections of this specification is not implied. Exposure to absolute maximum rating conditions for extended periods may affect reliability.

### DC Electrical Characteristics (TA = -40°C to +85°C V<sub>CC</sub> = 3.3V ±0.3V)

Symbol	Parameter	Test Condition <sup>(1)</sup>	Min.	Typ.	Max.	Units
V <sub>OH</sub>	Output High Voltage	V <sub>CC</sub> = Min., V <sub>IN</sub> = V <sub>IL</sub> or V <sub>IH</sub> I <sub>OH</sub> = -0.1mA I <sub>OH</sub> = -8mA	V <sub>CC</sub> - 0.2 2.4	- 3.0		V
V <sub>OL</sub>	Output Low Voltage	V <sub>CC</sub> = Min., V <sub>IN</sub> = V <sub>IL</sub> or V <sub>IH</sub> I <sub>OH</sub> = 0.1mA I <sub>OH</sub> = 16mA I <sub>OH</sub> = 24mA		- 0.2 0.3	0.2 0.4 0.5	
V <sub>IH</sub>	Input High Voltage	Guaranteed Logic HIGH Level (Input pins)	2.0		5.5	
V <sub>IL</sub>	Input Low Voltage	Guaranteed Logic LOW Level (Input pins)	-0.5		0.8	
I <sub>IH</sub>	Input High Current	V <sub>CC</sub> = Max. V <sub>IN</sub> = V <sub>CC</sub>			1	µA
I <sub>IL</sub>	Input Low Current	V <sub>CC</sub> = Max. V <sub>IN</sub> = GND			-1	
V <sub>IK</sub>	Clamp Diode Voltage	V <sub>CC</sub> = Min., I <sub>IN</sub> = -18mA		-0.7	-1.2	V
I <sub>OH</sub>	Output HIGH Current <sup>(4,5)</sup>	V <sub>OUT</sub> = 1.5V, V <sub>IN</sub> = V <sub>IL</sub> or V <sub>IH</sub> , V <sub>CC</sub> = 3.3V	-35	-60	-110	mA
I <sub>OL</sub>	Output LOW Current <sup>(4,5)</sup>	V <sub>OUT</sub> = 1.5V, V <sub>IN</sub> = V <sub>IL</sub> or V <sub>IH</sub> , V <sub>CC</sub> = 3.3V	50	90	200	
I <sub>OS</sub>	Short Circuit Current <sup>(4,5)</sup>	V <sub>CC</sub> = Max., V <sub>OUT</sub> = GND	-60	-135	-240	
V <sub>H</sub>	Input Hysteresis			150		mV

**Notes:**

1. For Max. or Min. conditions, use appropriate value specified under Electrical Characteristics for the applicable device type.
2. Typical values are at V<sub>CC</sub> = 3.3V, +25°C ambient and maximum loading.
3. V<sub>OH</sub> = V<sub>CC</sub> - 0.6V at rated current.
4. This parameter is determined by device characterization but is not production tested.
5. Not more than one output should be shorted at one time. Duration of the test should not exceed one second.

**Power Supply Characteristics**

Parameters	Description	Test Conditions <sup>(1)</sup>		Min.	Typ <sup>(2)</sup>	Max.	Units
I <sub>CC</sub>	Quiescent Power Supply Current	V <sub>CC</sub> = Max.	V <sub>IN</sub> = GND or V <sub>CC</sub>	—	3	30	μA
ΔI <sub>CC</sub>	Supply Current per Inputs @ TTL HIGH	V <sub>CC</sub> = Max.	V <sub>IN</sub> = V <sub>CC</sub> - 0.6V <sup>(3)</sup>	—	2.0	300	
I <sub>CCD</sub>	Supply Current per Input per MHz <sup>(4)</sup>	V <sub>CC</sub> = Max., Outputs Open Per Output Toggling 50% Duty Cycle	V <sub>IN</sub> = V <sub>CC</sub> V <sub>IN</sub> = GND	—			mA/ MHz

**Notes:**

- For Max. or Min. conditions, use appropriate value specified under Electrical Characteristics for the applicable device.
- Typical values are at V<sub>CC</sub> = 3.3V, +25°C ambient.
- Per TTL driven input (V<sub>IN</sub> = V<sub>CC</sub> - 0.6V); all other inputs at V<sub>CC</sub> or GND.
- This parameter is not directly testable, but is derived for use in Total Power Supply Calculations.
- Values for these conditions are examples of the I<sub>C</sub> formula. These limits are guaranteed but not tested.

**Capacitance** (T<sub>A</sub> = 25°C, f = 1 MHz)

Parameters <sup>(1)</sup>	Description	Test Conditions	Typ	Max.	Units
C <sub>IN</sub>	Input Capacitance	V <sub>IN</sub> = 0V	4.5	6.0	pF
C <sub>OUT</sub>	Output Capacitance	V <sub>OUT</sub> = 0V	5.5	8.0	

**Notes:**

- This parameter is determined by device characterization but is not production tested.

**Maximum Switching Characteristics** (Over operating range)

Symbol	Description	Test Conditions	3807		3087A		3087B		3807C		Units
			Com.		Com.		Com.		Com.		
			Min.	Max.	Min.	Max.	Min.	Max.	Min.	Max.	
t <sub>PLH</sub> t <sub>PHL</sub>	Propagation Delay A to B <sub>N</sub>	C <sub>L</sub> = 15pF R <sub>L</sub> = 500Ω	1.5	4.5	1.5	4.0	1.5	3.8	1.5	3.5	ns
t <sub>SK(O)</sub>	Skew between two outputs of same package <sup>(3)</sup>			0.5		0.5		0.5		0.5	
t <sub>SK(P)</sub>	Skew between opposite transitions of the same output (t <sub>PHL</sub> - t <sub>PHL</sub> ) <sup>(3)</sup>			0.5		0.5		0.35		0.35	
F <sub>IN</sub>	Skew between outputs of different packages at the same power supply, temp. and speed grade <sup>(3)</sup>			1.0		1.0		0.75		0.75	

**Notes:**

- Other loading condition is described on page 4, “Test Circuits for All Outputs.”
- These parameters are guaranteed by design.
- Minimum propagation delay of 1.5ns is guaranteed by design.

**Phase Jitter Measurement Data**

Frequency Band	Input	Output	Additive Jitter	Unit
12kHz-10MHz	342	483	341	f <sub>SRMS</sub>
12kHz-20MHz	493	642	411	f <sub>SRMS</sub>

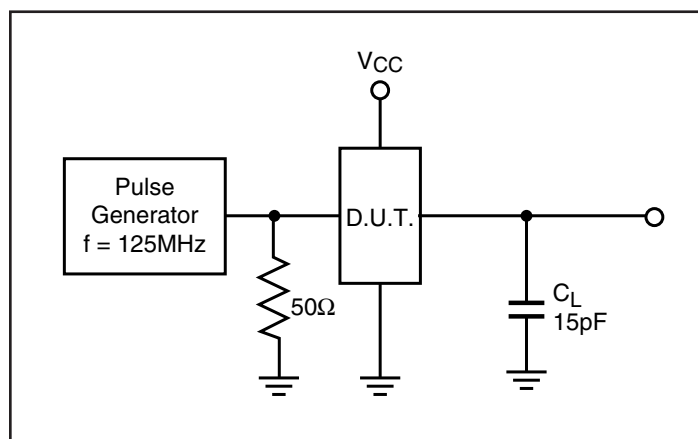
**Tests Circuits for All Outputs**

**Switch Position**

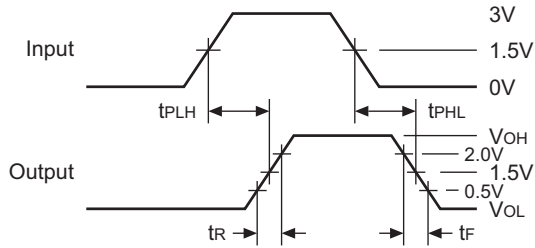
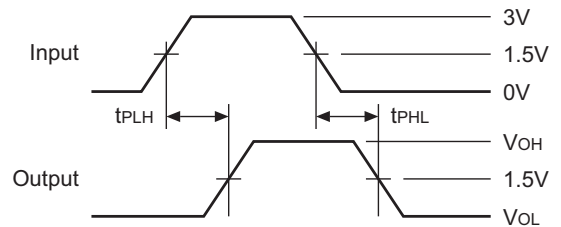
Test	Switch
Disable LOW Enable LOW	6V
Disable HIGH Enable HIGH	GND
All Other Inputs	Open

**Switching Waveforms**
**Propagation Delay**

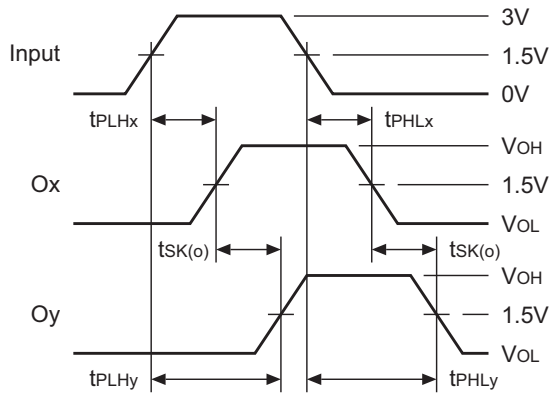
**Pulse Skew –  $t_{SK(p)}$** 

$$t_{SK(p)} = |t_{PHL} - t_{PLH}|$$

**Output Skew –  $t_{SK(o)}$** 

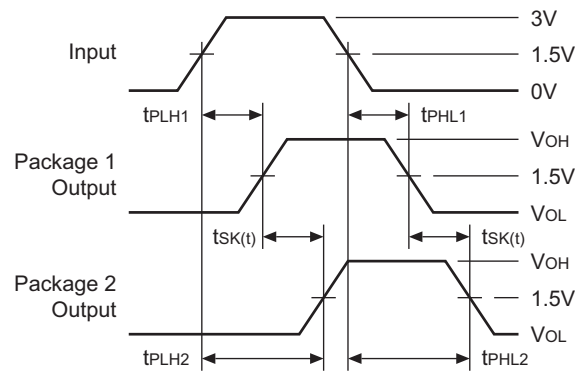
$$t_{SK(o)} = |t_{PLHy} - t_{PLHx}| \text{ or } |t_{PHLy} - t_{PHLx}|$$

**Package Skew –  $t_{SK(t)}$** 

$$t_{SK(t)} = |t_{PLH2} - t_{PLH1}| \text{ or } |t_{PHL2} - t_{PHL1}|$$

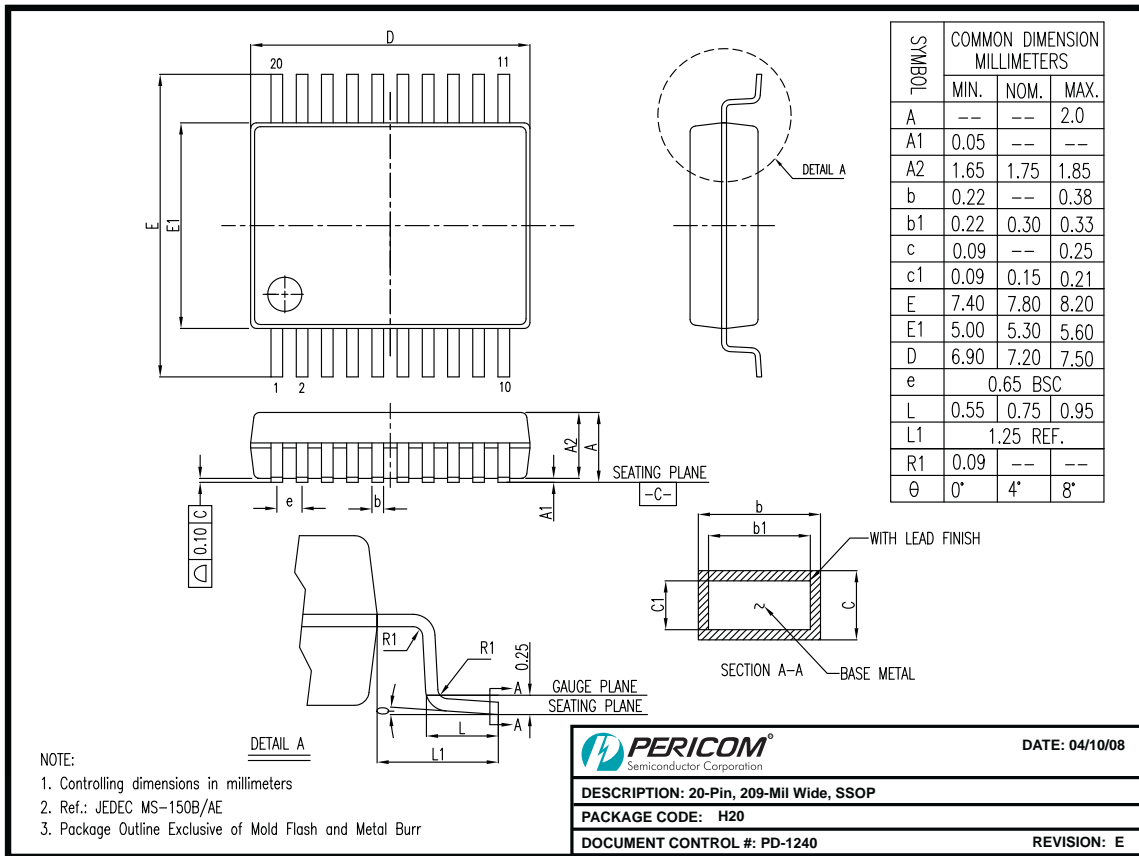

08-0140

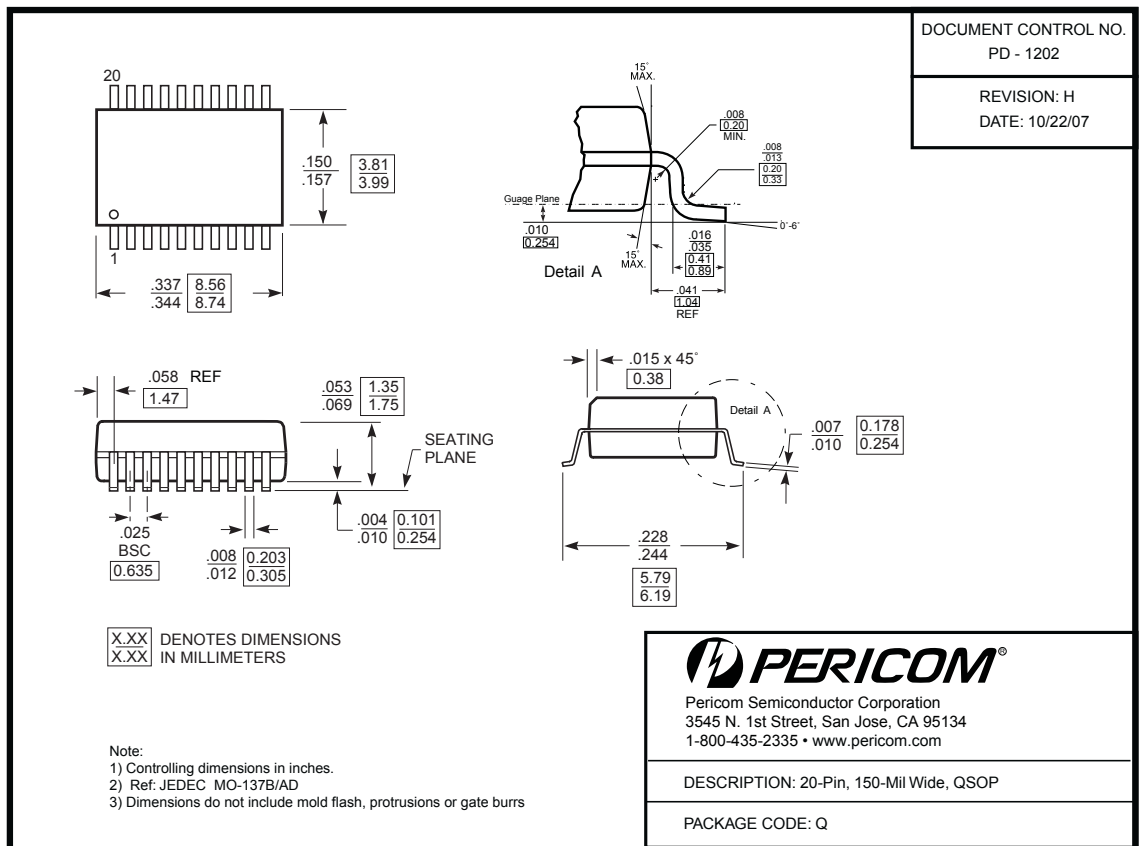

DOCUMENT CONTROL NO.  
PD - 1006

REVISION: D  
DATE: 03/09/05

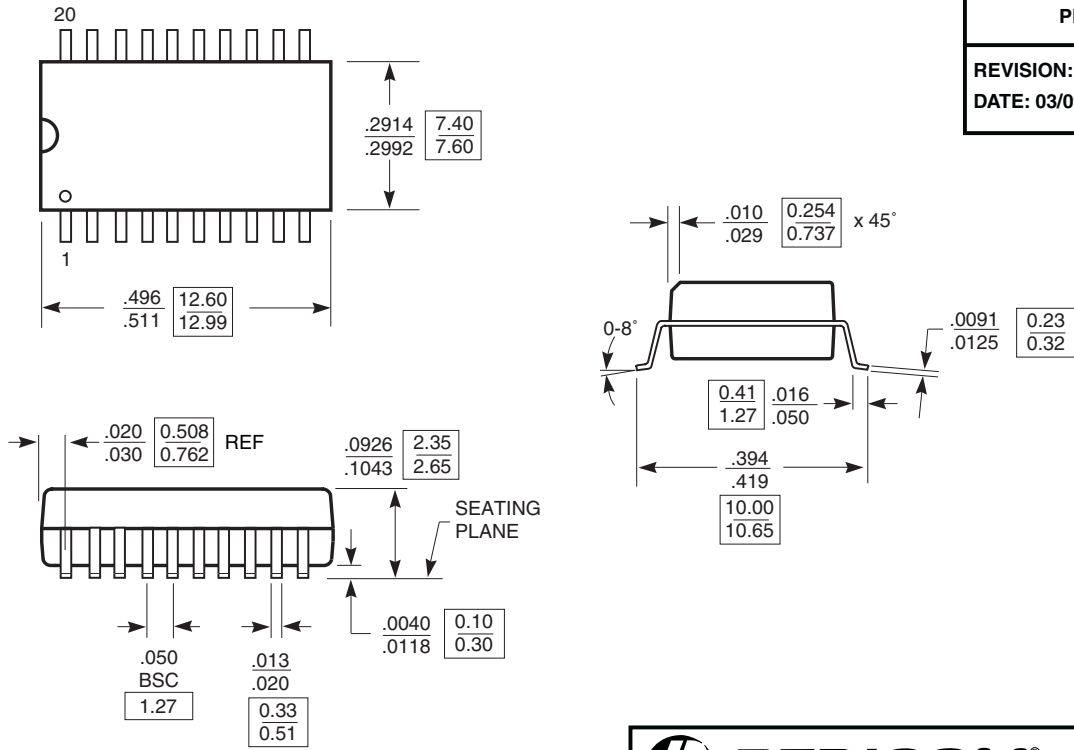

X.XX DENOTES CONTROLLING  
X.XX DIMENSIONS IN MILLIMETERS

**Notes:**

- 1) Controlling dimensions in millimeters.
- 2) Ref: JEDEC MS-013D/AC



Pericom Semiconductor Corporation  
3545 N. 1st Street, San Jose, CA 95134  
1-800-435-2335 • www.pericom.com

DESCRIPTION: 20-Pin, 300-Mil Wide, SOIC

PACKAGE CODE: S

**Note:**

- For latest package info, please check: <http://www.pericom.com/products/packaging/mechanicals.php>

**Ordering Information**

Ordering Code	Package Code	Speed Grade	Package Description
PI49FCT3807AHEX	H	A	Pb-free & Green, 20-pin 209-mil SSOP
PI49FCT3807AQEX	Q	A	Pb-free & Green, 20-pin 150-mil QSOP
PI49FCT3807ASEX	S	A	Pb-free & Green, 20-pin 300-mil SOIC
PI49FCT3807BHEX	H	B	Pb-free & Green, 20-pin 209-mil SSOP
PI49FCT3807BQEX	Q	B	Pb-free & Green, 20-pin 150-mil QSOP
PI49FCT3807BSEX	S	B	Pb-free & Green, 20-pin 300-mil SOIC
PI49FCT3807CHEX	H	C	Pb-free & Green, 20-pin 209-mil SSOP
PI49FCT3807CQEX	Q	C	Pb-free & Green, 20-pin 150-mil QSOP
PI49FCT3807CSEX	S	C	Pb-free & Green, 20-pin 300-mil SOIC
PI49FCT3807DHEX	H	D	Pb-free & Green, 20-pin 209-mil SSOP
PI49FCT3807DQEX	Q	D	Pb-free & Green, 20-pin 150-mil QSOP
PI49FCT3807DSEX	S	D	Pb-free & Green, 20-pin 300-mil SOIC
PI49FCT3807HEX	H	Blank	Pb-free & Green, 20-pin 209-mil SSOP
PI49FCT3807QEX	Q	Blank	Pb-free & Green, 20-pin 150-mil QSOP
PI49FCT3807SEX	S	Blank	Pb-free & Green, 20-pin 300-mil SOIC

**Notes:**

- Thermal characteristics can be found on the company web site at [www.pericom.com/packaging/](http://www.pericom.com/packaging/)
- E = Pb-free and Green
- Adding an X suffix = Tape/Reel



# Mouser Electronics

Authorized Distributor

Click to View Pricing, Inventory, Delivery & Lifecycle Information:

## Diodes Incorporated:

[PI6C185-00QEX](#) [PI6C185-00QIE](#) [PI6C185-00QIEX](#) [PI6C185-01QE](#) [PI6C185-01QEX](#) [PI6C185-01QIE](#)  
[PI6UMC10802-1ZMEX](#) [PI6C182AHE](#) [PI6C4022ZLE](#) [PI6C4022ZLEX](#) [PI49FCT2805BTQE](#) [PI49FCT3807BSE](#)  
[PI49FCT2805TQE](#) [PI49FCT3807SE](#) [PI49FCT3807BHE](#) [PI49FCT2805TSE](#) [PI49FCT3807SEX](#) [PI6C180BVE](#)  
[PI49FCT2805TQEX](#) [PI6C182BHEX](#) [PI6C184HE](#) [PI49FCT2805TSEX](#) [PI49FCT3807BSEX](#) [PI6C182BHE](#)  
[PI49FCT3807BHEX](#) [PI6C180BVEX](#) [PI49FCT32807SEX](#) [PI6C184HEX](#) [PI49FCT3807CHE](#) [PI49FCT3807AQE](#)  
[PI49FCT3807CQEX](#) [PI49FCT3807BQE](#) [PI49FCT3807ASEX](#) [PI49FCT3807CSE](#) [PI49FCT3807CSEX](#)  
[PI49FCT3807DHE](#) [PI49FCT3807QE](#) [PI49FCT3807AHEX](#) [PI49FCT3807DQEX](#) [PI49FCT3807CHEX](#)  
[PI49FCT3807DQE](#) [PI49FCT3807ASE](#) [PI49FCT3807DHEX](#) [PI6C182HE](#) [PI6C182AHEX](#) [PI49FCT3807QEX](#)  
[PI49FCT3807AQEX](#) [PI6C182HEX](#) [PI49FCT3807BQEX](#) [PI49FCT3807CQE](#) [PI49FCT3807HEX](#) [PI49FCT3807AHE](#)  
[PI49FCT3807HE](#) [PI6C10806LEX](#) [PI6CL10807LE](#) [PI6C10808LEX](#) [PI6CL10807LEX](#) [PI6C41204LIE](#) [PI6C10808LE](#)  
[PI6C41204LIEX](#) [PI6CL10806LEX](#) [PI49FCT38072BHEX](#) [PI49FCT38072CQE](#) [PI49FCT38072CQEX](#)  
[PI49FCT3807BQE+AMX](#) [PI49FCT38072BHE](#) [PI49FCT3807BQE+AM-1507](#) [PI49FCT3807BQE+AMX-1507](#)  
[PI49FCT3807BQE-1507](#) [PI49FCT3807BQE+AM](#) [PI49FCT32807HE-2017](#) [PI49FCT3807AHE-2017](#)  
[PI49FCT3807AHEX-2017](#) [PI49FCT3807BQE-2017](#) [PI49FCT3807DQEX-2017](#) [PI49FCT3807BQEX-2017](#)  
[PI49FCT3807CHE-2017](#) [PI49FCT3807CHEX-2017](#) [PI49FCT3807DHE-2017](#) [PI49FCT3807DHEX-2017](#)  
[PI49FCT3807DQE-2017](#)