

High-Speed Isolated TTL-Level
Digital I/O Board for PCI (Internal power supply)
PIO-16/16TB(PCI)H



* Specifications, color and design of the products are subject to change without notice.

Features

The PCI bus (personal computer) and the I/O interface are isolated from each other by an Optocoupler, offering good noise immunity.

The connector pin assignment is compatible with the one of PIO-16/16TB(PCI).

16 TTL level isolated input of digital signal.
16 TTL level isolated output of digital signal.

You can use all of the input signals as interrupt events. You can also select the interrupt trigger edge of the input signal.

The board has a digital filter feature to prevent wrong recognition of input signals from carrying noise or a chattering.

An on-board isolated supply (5VDC, 600mA) is equipped. You can select to use either this on board supply or external power supply for driving photo-insulation circuits.

Specification

Item	Specification
Input	
Input format	Optocoupler isolated TTL level input (Negative logic *1)
Number of input signal channels	16 channels (all available for interrupts)
Input resistance	1.1kΩ
Interrupt	16 interrupt input signals are arranged into a single output of interrupt signal INTA. An interrupt is generated at the rising edge (HIGH-to-LOW transition) or falling edge (LOW-to-HIGH transition).
Response time	1μsec within
Output	
Output format	Optocoupler isolated TTL level output (Negative logic*1)
Number of output signal channels	16 channels
Output rating	5VDC (Max.)
Output voltage	5VDC (Max.)
Output current	Typical 6.4mA (par channel) (4 TTL loads)
Response time	1μsec within
Common	
I/O address	Any 32-byte boundary
Max. board count for connection	16 boards
Power consumption *2	5VDC 1150mA (Max.) (Using the internal power) 5VDC 350mA (Max.) (Using the external power)
Operating condition	0 - 50°C, 10 - 90%RH(No condensation)
Allowable distance of signal extension	Approx. 5m (depending on wiring environment)
PCI bus specification	33bit, 33MHz, Universal key shapes supported *3
Dimension (mm)	176.41(L) x 105.68(H)
Weight	130g
Certification	RoHS,CE,VCCI

*1 Data "0" and "1" correspond to the High and Low levels, respectively.
*2 When the internal power supply is used, the input section consumes a maximum of 51 mA and the output channel switching section consumes a maximum of 102.4mA. In this case, therefore, the output current to be supplied from the board is 446.6 mA.
*3 This board requires +5V power supply from expansion slots (it does not operate in the environment of only +3.3V power supply).

Board Dimensions

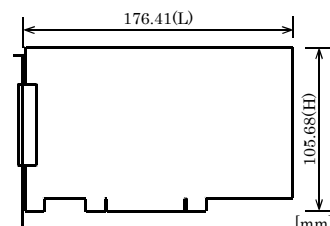

The standard outside dimension (L) is the distance from the end of the board to the outer surface of the slot cover.

Support Software

Windows version of digital I/O driver API-DIO(WDM) / API-DIO(98/PC)

[Stored on the bundled Disk driver library API-PAC(W32)]

The API-DIO(WDM) / API-DIO(98/PC) is the Windows version driver library software that provides products in the form of Win32 API functions (DLL). Various sample programs such as Visual Basic and Visual C++, etc and diagnostic program useful for checking operation is provided.

You can download the updated version from the CONTEC's Web site (<http://www.contec.com/apipac/>). For more details on the supported OS, applicable language and new information, please visit the CONTEC's Web site.

Linux version of digital I/O driver API-DIO(LNX) [Stored on the bundled Disk driver library API-PAC(W32)]

The API-DIO(LNX) is the Linux version driver software which provides device drivers (modules) by shared library and kernel version. Various sample programs of gcc are provided.

You can download the updated version from the CONTEC's Web site (<http://www.contec.com/apipac/>). For more details on the supported OS, applicable language and new information, please visit the CONTEC's Web site.

Data acquisition VI library for LabVIEW VI-DAQ (Free download)

This is a VI library to use in National Instruments LabVIEW. VI-DAQ is created with a function form similar to that of LabVIEW's Data Acquisition VI, allowing you to use various devices without complicated settings.

See <http://www.contec.com/vidaq/> for details and download of VI-DAQ.

Cable & Connector

Cable (Option)

Shield Cable with 37-Pin D-SUB Connector at either Ends (Mold Type)

- : PCB37PS-0.5P (0.5m)
- : PCB37PS-1.5P (1.5m)
- : PCB37PS-3P (3m)
- : PCB37PS-5P (5m)

Flat Cable with 37-Pin D-SUB Connectors at either Ends

- : PCB37P-1.5 (/1.5m)
- : PCB37P-3 (3m)
- : PCB37P-5 (5m)

Flat Cable with 37-Pin D-SUB Connector at One End

- : PCA37P-1.5 (1.5m)
- : PCA37P-3 (3m)
- : PCA37P-5 (5m)

Shield Cable with 37-Pin D-SUB Connector at One End (Mold Type)

- : PCA37PS-0.5P (0.5m)
- : PCA37PS-1.5P (1.5m)
- : PCA37PS-3P (3m)
- : PCA37PS-5P (5m)

Connector (Option)

D-SUB37P Male Connector Set (5 Pieces)
: CN5-D37M

Accessories

Accessories (Option)

- Screw Terminal (M3 x 37P) : EPD-37A *1*2
- Screw Terminal (M3.5 x 37P) : EPD-37 *1
- General Purpose Terminal : DTP-3A *1
- Screw Terminal : DTP-4A *1
- Signal Monitor for Digital I/O : CM-32L *1

*1 PCB37P-1.5, PCB37PS-0.5P and PCB37PS-1.5P optional cable is required separately.

*2 "Spring-up" type terminal is used to prevent terminal screws from falling off.

* Check the CONTEC's Web site for more information on these options.

Packing List

Board [PIO-16/16TB(PCI)H] ...1
 First step guide ...1
 Disk *1 [API-PAC(W32)] ...1
 Serial number label...1
 Product Registration Card & Warranty Certificate...1

*1 The Disk contains the driver software and User's Guide.

Block Diagram

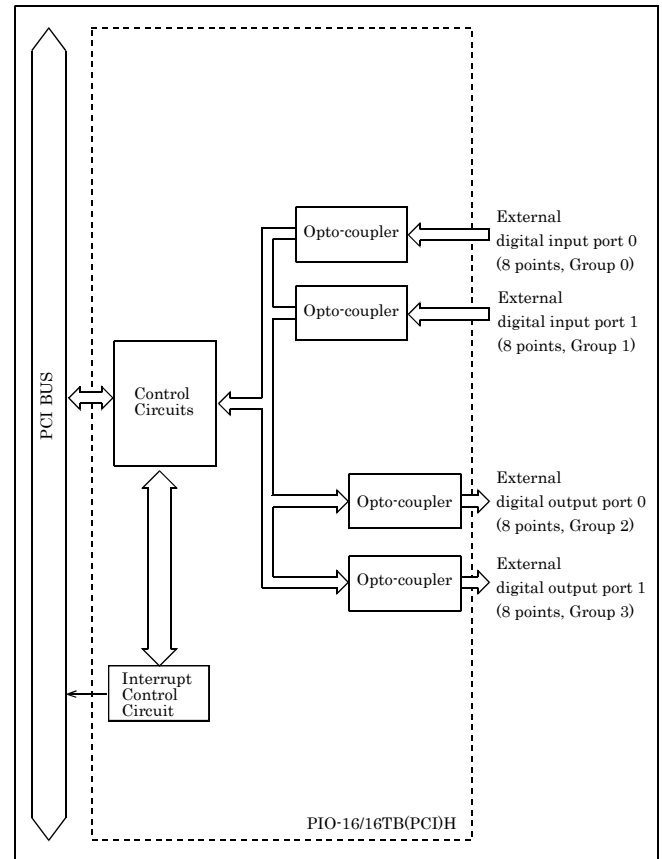

Using the On-board Connectors

Connecting a Device to a Connector

To connect an external device to this board, plug the cable from the device into the interface connector (CN1).

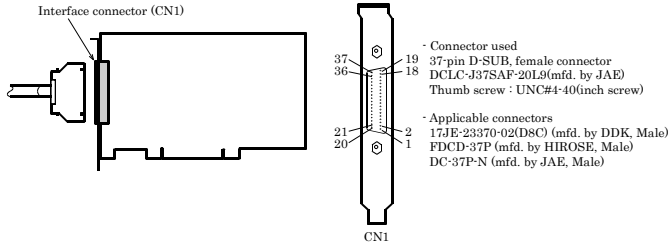

Pin Assignments of Interface Connector

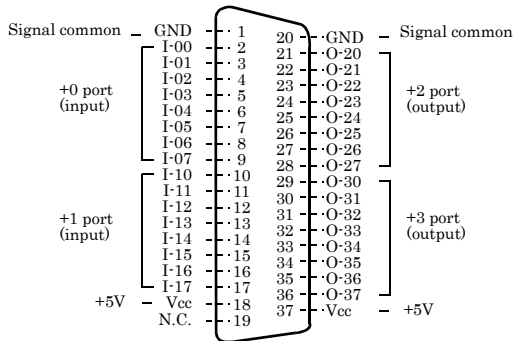

I-00 - I-17	16 input signal pins. Connect output signals from the external device to these pins.
O-20 - O-37	16 output signal pins. Connect these pins to the input signal pins of the external device.
Vcc	When the internal power supply is used, this pin outputs power at +5 V. When the external power supply is used, its positive side is connected to this pin.
Gnd	When the internal power supply is used, this pin outputs power at GND. When the external power supply is used, its negative side is connected to this pin.
N.C.	This pin is left unconnected.

Connecting Input Signals

The external digital signal, with connected to the input logic, should be a TTL level signal.

The computer will recognize this input signal by a negative logic.

All the input signals are pull-upped on board therefore a relay switch signal or a semiconductor switch signal can be directly connected between the input signal and the minus common(GND).

Input Circuit

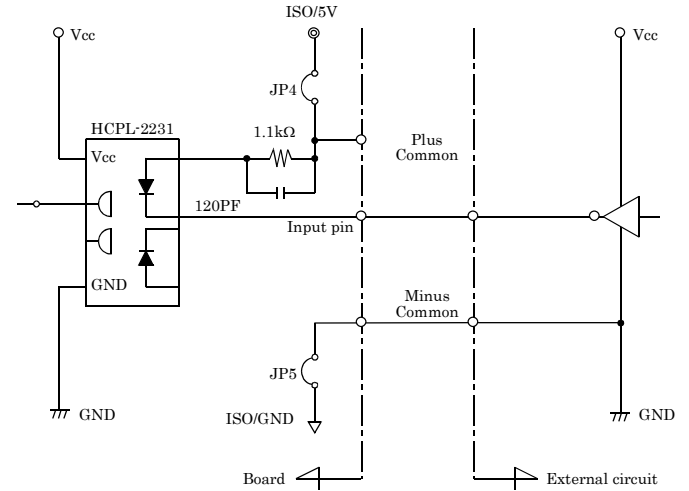

* Input pin is I-xx.

The input circuits of interface blocks of this product are illustrated in the image above. The signal inputs are isolated by the Optocoupler. The board therefore requires an additional power supply isolated from the PC system to drive the photo-isolated circuits. The board offers you an on-board isolated 5VDC power supply in option. In this case (using external supply), 4.5mA current is requested each channel on 5VDC.

Connecting a Switch

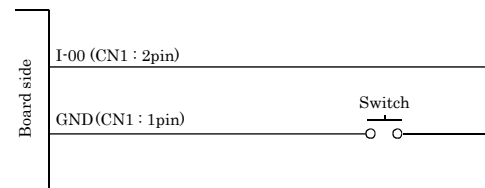

When the switch is ON, the corresponding bit contains 1.
When the switch is OFF, by contrast, the bit contains 0.

Connecting Output Signals

The output signals are TTL level signals. The board uses a negative logic to output the signals.

Output Circuit

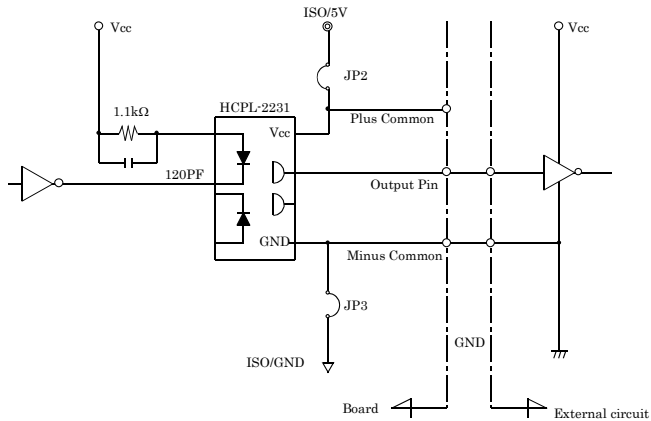

* Output pin is O-xx.

The output circuits of interface blocks of the PIO-16/16TB(PCI)H are illustrated in the image above. The signal output section is an opto-coupler isolated, TTL level output. Driving the output section requires an additional power supply isolated from the PC system. The board offers you an on-board isolated 5VDC power supply in option.

CAUTION

The Opto-coupler "HCPL-2231" used on this board, with power turned, feeds low-level output when the primary circuit is not driven.

Using the external power supply:

The Opto-coupler keeps on outputting low-level while the external power supply is turned on and the PC is off.

Using the internal power supply:

Since the internal power supply ISO 5V is enabled earlier than the PC's Vcc, the opto-coupler outputs the low level for several ms while the PC is off or before the PC is turned on.

Connection to the LED

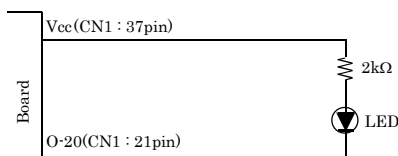

When "1" is output to a relevant bit, the corresponding LED comes on.
When "0" is output to the pin, in contrast, the LED goes out.

Differences between the PIO-16/16TB(PCI)H and PIO-16/16TB(PCI)

This product is connector-pin compatible with the conventional PIO-16/16TB(PCI) but has the following differences from it:

- (1) Different in the number of input signals available to interrupt requests
 - PIO-16/16TB(PCI)H : All of 16 channels
 - PIO-16/16TB(PCI) : 4 channels
- (2) Different in the expression to calculate the digital filter time (n: setting value)
 - PIO-16/16TB(PCI)H : $2^n / (8 \times 10^6)$
 - PIO-16/16TB(PCI) : $2^n / (16 \times 10^6)$
- (3) Different in interrupt level resource allocation
 - PIO-16/16TB(PCI)H : Automatically allocates on interrupt level.
 - PIO-16/16TB(PCI) : Uses a jumper switch to select whether to allocate interrupt levels.
- (4) Different in board dimensions
 - PIO-16/16TB(PCI)H : 176.41(L) x 105.68(H)mm
 - PIO-16/16TB(PCI) : 176.41(L) x 106.68(H) mm
- (5) Different in current consumption (Max.)
 - PIO-16/16TB(PCI)H : 5VDC 350mA(Max.) (When using the external power supply)
 - PIO-16/16TB(PCI) : 5VDC 500mA(Max.) (When using the external power supply)