

Remote I/O R5 Series

THERMOCOUPLE INPUT MODULE

(re-transmitted output)

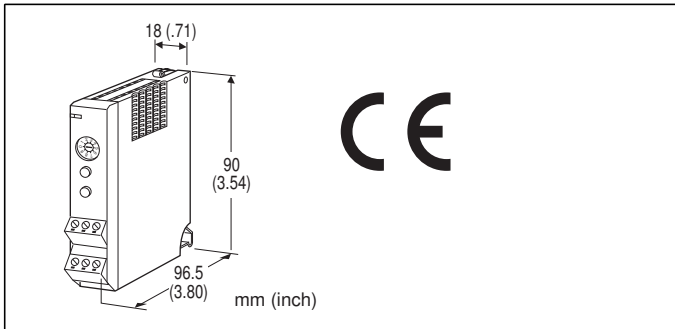

MODEL: R5-TS1A[1][2]

ORDERING INFORMATION

- Code number: R5-TS1A[1][2]
- Specify a code from below for each of [1] and [2].
(e.g. R5-TS1AW/Q)
- Specify the specification for option code /Q
(e.g. /C01)

NO. OF CHANNELS

1: 1 channel

OUTPUT

Current

A: 4 - 20 mA DC (Load resistance 600 Ω max.)

[1] COMMUNICATION MODE

S: Single

W: Dual

[2] OPTIONS

blank: none

/Q: With options (specify the specification)

SPECIFICATIONS OF OPTION: Q

COATING (For the detail, refer to M-System's web site.)

/C01: Silicone coating

/C02: Polyurethane coating

/C03: Rubber coating

GENERAL SPECIFICATIONS

Connection

Internal bus: Via the Installation Base (model: R5-BS)

I/O: Euro type connector terminal

(Applicable wire size: 0.2 - 2.5 mm² (AWG24 - 12),
stripped length 7 mm)

Internal power: Via the base (model: R5-BS)

Isolation: Input to output to internal bus or internal power

Zero/Span adj. mode selector: Rotary switch; monitor mode,
adj. mode and simulated output mode selectable

Sensor type: Selectable with the side DIP SW

Temperature unit: °C, °F or absolute temperature selectable
with the side DIP SW

Burnout detection: Upscale or downscale selectable with the
side DIP SW

Linearization: Standard

Cold junction compensation: CJC sensor attached to the
input terminals

RUN indicator: Bi-color (red/green) LED;

Red when the bus A operates normally;

Green when the bus B operates normally;

Amber when both buses operate normally.

INPUT SPECIFICATIONS

Input resistance: 30 kΩ min.

Burnout sensing: ≤ 0.1 μA

Temperature range

T/C	°C	
	USABLE RANGE	CONFORMANCE RANGE
K (CA) (*)* ¹	-272 to +1472	-150 to +1370
E (CRC) * ¹	-272 to +1120	-170 to +1000
J (IC)	-260 to +1300	-180 to +1200
T (CC) * ¹	-272 to +500	-170 to +400
B (RH) * ¹	24 to 1920	400 to 1760
R	-100 to +1860	200 to 1760
S	-100 to +1860	0 to 1760
C (WRe 5-26)	-52 to +2416	0 to 2315
N * ¹	-272 to +1400	-130 to +1300
U	-252 to +700	-200 to +600
L	-252 to +1000	-200 to +900
P (Platinel II)	-52 to +1496	0 to 1395
(PR)	-52 to +1860	0 to 1760
T/C	°F	
	USABLE RANGE	CONFORMANCE RANGE
K (CA) * ¹	-458 to +2682	-238 to +2498
E (CRC) * ¹	-458 to +2048	-274 to +1832
J (IC)	-436 to +2372	-292 to +2192
T (CC) * ¹	-458 to +932	-274 to +752
B (RH) * ¹	75 to 3488	752 to 3200
R	-148 to +3380	392 to 3200
S	-148 to +3380	32 to 3200
C (WRe 5-26)	-62 to +4381	32 to 4199
N * ¹	-458 to +2552	-202 to +2372
U	-422 to +1292	-328 to +1112
L	-422 to +1832	-328 to +1652
P (Platinel II)	-62 to +2725	32 to 2543
(PR)	-62 to +3380	32 to 3200

(*): Factory setting. Set the input range within 0-1000°C corresponding to the output range 0-10000.

*1. Accuracy degrades at temperatures close to the lower limit of the usable range.

Max. (upscale) or min. (downscale) value of the usable range when a burnout is detected.

OUTPUT SPECIFICATIONS

Operational range: Approx. 0 – 24 mA DC

INSTALLATION

Operating temperature: -10 to +55°C (14 to 131°F)

Operating humidity: 30 to 90 %RH (non-condensing)

Atmosphere: No corrosive gas or heavy dust

Mounting: Installation Base (model: R5-BS)

Weight: 100 g (3.53 oz)

PERFORMANCE

Conversion accuracy

Input: $\pm 0.4^{\circ}\text{C}$ ($\pm 0.6^{\circ}\text{C}$ for C thermocouple)

$\pm 0.8^{\circ}\text{F}$ ($\pm 1.1^{\circ}\text{F}$ for C thermocouple)

Output: $\pm 0.1\%$ of the retransmitted range + input conversion accuracy (May exceed $\pm 0.1\%$ depending upon the input temperature range.)

Conversion data: Temperature data scaled and converted into 0 – 100 % data and supplied to the internal network bus

Data allocation: 1

Cold junction compensation error: $\pm 0.5^{\circ}\text{C}$ or $\pm 0.9^{\circ}\text{F}$
(at $20^{\circ}\text{C} \pm 10^{\circ}\text{C}$ or $68^{\circ}\text{F} \pm 18^{\circ}\text{F}$)

Temp. coefficient

Input: $\pm 0.015\%/^{\circ}\text{C}$ ($\pm 0.008\%/^{\circ}\text{F}$)

Output: $\pm 0.02\%/^{\circ}\text{C}$ ($\pm 0.01\%/^{\circ}\text{F}$)

Response time: ≤ 0.4 sec. (0 – 90 %)

Burnout response time: ≤ 2 sec.

Insulation resistance: $\geq 100\ \text{M}\Omega$ with 500 V DC

Dielectric strength: 1500 V AC @ 1 minute (input to output to internal bus or internal power)

2000 V AC @ 1 minute (power input to FG; isolated on the power supply module)

STANDARDS & APPROVALS

EU conformity:

EMC Directive

EMI EN 61000-6-4

EMS EN 61000-6-2

RoHS Directive

EN 50581

FUNCTIONS

• Zero/Span Adjustment Modes

Monitor Mode

Re-transmits the input signal as output in proportion.

Output 0 % Adjustment Mode

Adjusts the 0 % output signal using the front UP/DOWN buttons, in monitoring the output value with a multimeter. SW1 through SW3 switch the internal increments by 1, 5 and 10.

Output 100 % Adjustment Mode

Adjusts the 100 % output signal using the front UP/DOWN buttons, in monitoring the output value with a multimeter. SW4 through SW6 switch the internal increments by 1, 5 and 10.

Simulated Output Mode

Outputs the simulated signals of 0 %, 50 % and 100 %.

• How to Operate

- 1) Start up in Monitor Mode (SW position = 0) and wait for 2 or 3 seconds.
- 2) Switch to another mode and go through the adjustments.
- 3) Reset the switch to the position '0' so that the new setting is stored in the internal memory.

EXTERNAL VIEW

■ SIDE VIEW

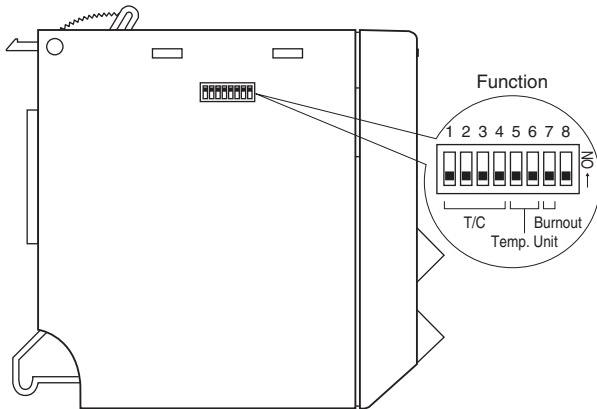

■ FRONT VIEW

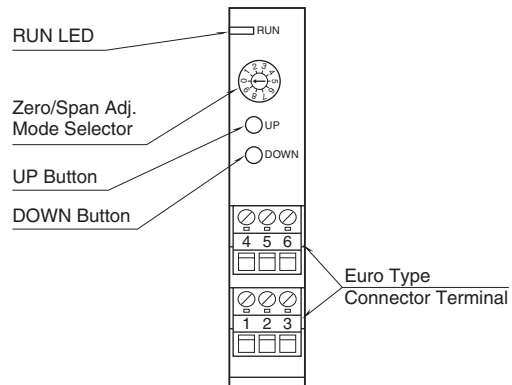

EXTERNAL DIMENSIONS & TERMINAL ASSIGNMENTS unit: mm (inch)

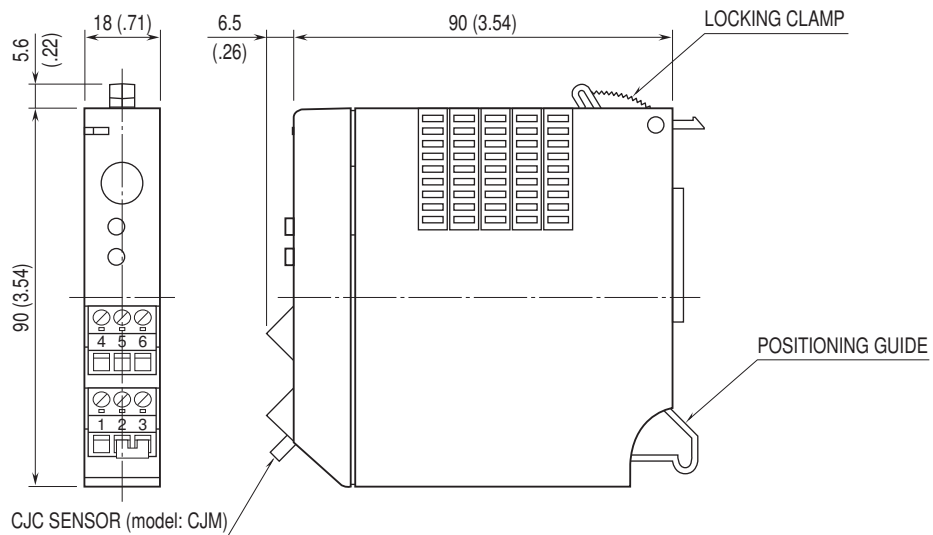

SCHEMATIC CIRCUITRY & CONNECTION DIAGRAM

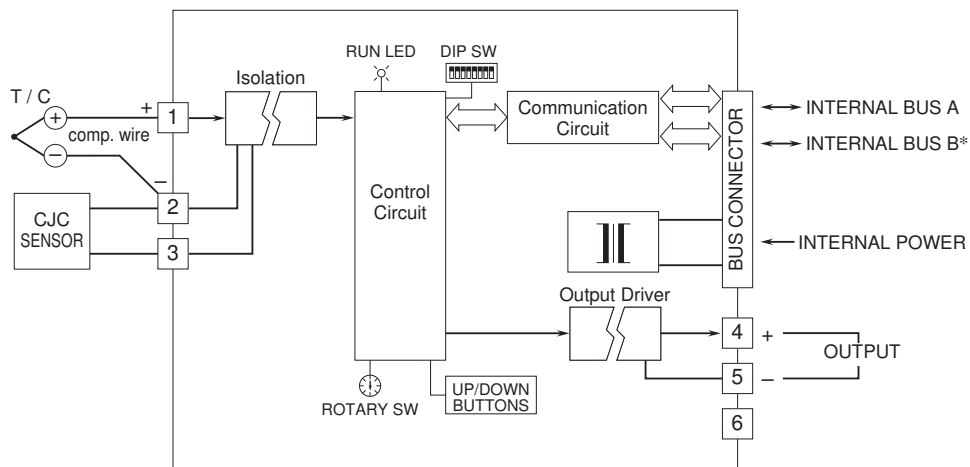

*For dual redundant communication.



Specifications are subject to change without notice.