

## SN74AHC595 具有三态输出寄存器的 8 位移位寄存器

### 1 特性

- 工作范围：2V 至 5.5V  $V_{CC}$
- 8 位串行输入、并行输出移位寄存器
- 门锁性能超过 100mA，符合 JESD 78 II 类规范
- ESD 保护性能超过 JESD 22 规范要求
  - 2000V 人体放电模型 (A114-A)
  - 1000V 充电器件模型 (C101)

### 2 应用

- 网络交换机
- 电力基础设施
- LED 显示屏
- 服务器

### 3 说明

SN74AHC595 器件包含一个可对 8 位 D 类存储寄存器进行馈送的 8 位串行输入、并行输出移位寄存器。存储寄存器具有并行三态输出。移位寄存器和存储寄存器各自具备独立时钟。移位寄存器具有直接覆盖清除 (SRCLR) 输入以及用于级联结构的串行 (SER) 输入和串行输出。当输出使能端 (OE) 输入为高电平时，所有输出 (QH' 除外) 均处于高阻抗状态。

#### 封装信息

器件型号	封装 <sup>(1)</sup>	封装尺寸 <sup>(2)</sup>	本体尺寸 <sup>(3)</sup>
SN74AHC595	BQB ( WQFN , 16 )	3.5mm x 2.5mm	3.5mm x 2.5mm
	N ( PDIP , 16 )	19.31mm x 9.4mm	19.31mm x 6.35mm
	D ( SOIC , 16 )	9.90mm x 6mm	9.90mm x 3.90mm
	DB ( SSOP , 16 )	6.20mm x 7.8mm	6.20mm x 5.30mm
	PW ( TSSOP , 16 )	5.00mm x 6.4mm	5.00mm x 4.40mm

- (1) 如需了解更多信息，请参阅第 11 节。
- (2) 封装尺寸 (长 × 宽) 为标称值，并包括引脚 (如适用)。
- (3) 本体尺寸 (长 × 宽) 为标称值，不包括引脚。

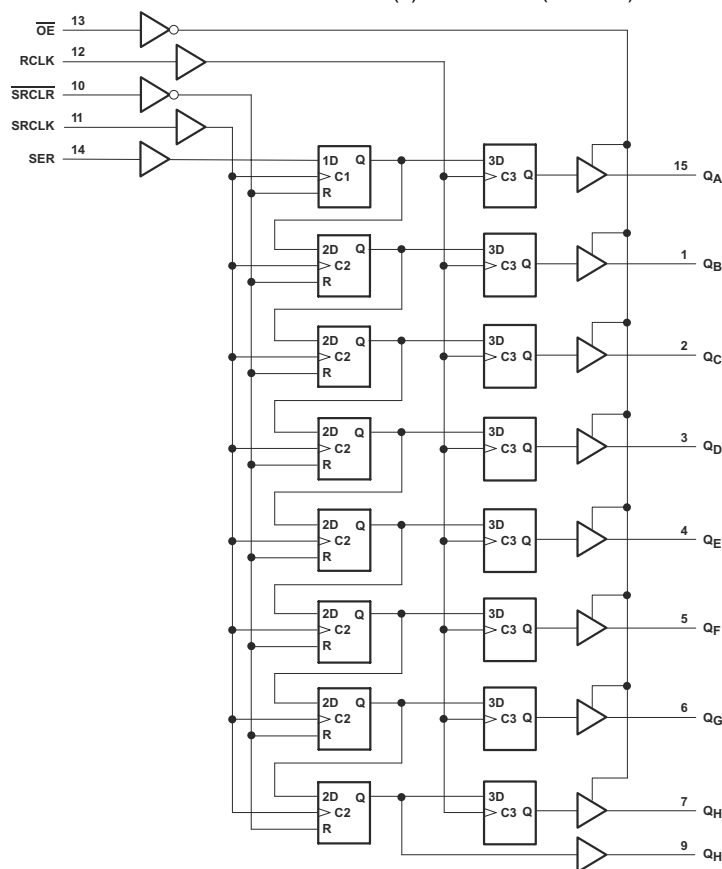

逻辑图 (正逻辑)



## Table of Contents

1 特性.....	1	7 Detailed Description.....	12
2 应用.....	1	8 Application and Implementation.....	14
3 说明.....	1	9 Device and Documentation Support.....	17
4 Pin Configuration and Functions.....	3	10 Revision History.....	18
5 Specifications.....	3	11 Mechanical, Packaging, and Orderable Information.....	18
6 Parameter Measurement Information.....	12		

---

## 4 Pin Configuration and Functions



图 4-1. D, DB, N, PW Packages 16-Pin SOIC, SSOP, PDIP, TSSOP (Top View)



图 4-2. BQB Package, 16-Pin WQFN (Top View)

表 4-1. Pin Functions

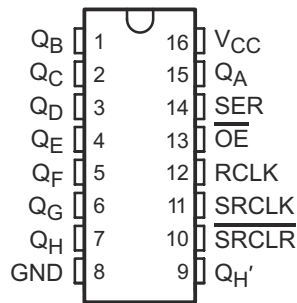
PIN		I/O	DESCRIPTION
NAME	NO.		
GND	8	—	Ground Pin
$\overline{OE}$	13	I	Output Enable
QA	15	O	QA Output
QB	1	O	QB Output
QC	2	O	QC Output
QD	3	O	QD Output
QE	4	O	QE Output
QF	5	O	QF Output
QG	6	O	QG Output
QH	7	O	QH Output
QH'	9	O	QH' Output
RCLK	12	I	RCLK Input
SER	14	I	SER Input
SRCLK	11	I	SRCLK Input
SRCLR	10	I	SRCLR Input
V <sub>CC</sub>	16	—	Power Pin

## 5 Specifications

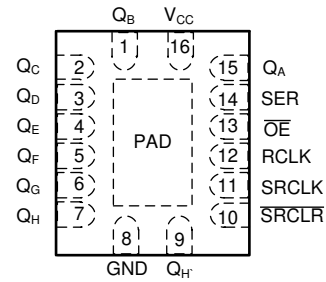
### 5.1 Absolute Maximum Ratings

over operating free-air temperature range (unless otherwise noted)<sup>(1)</sup>

			MIN	MAX	UNIT
V <sub>CC</sub>	Supply voltage		-0.5	7	V
V <sub>I</sub>	Input voltage <sup>(2)</sup>		-0.5	7	V
V <sub>O</sub>	Output voltage <sup>(2)</sup>		-0.5	V <sub>CC</sub> + 0.5	V
I <sub>IK</sub>	Input clamp current	(V <sub>I</sub> < 0)		-20	mA
I <sub>OK</sub>	Output clamp current	(V <sub>O</sub> < 0 or V <sub>O</sub> > V <sub>CC</sub> )		±20	mA
I <sub>O</sub>	Continuous output current	(V <sub>O</sub> = 0 to V <sub>CC</sub> )		±25	mA
	Continuous current through V <sub>CC</sub> or GND			±75	mA
T <sub>J</sub>	Junction temperature			150	°C

over operating free-air temperature range (unless otherwise noted)<sup>(1)</sup>

		MIN	MAX	UNIT
T <sub>stg</sub>	Storage temperature	-65	150	°C

- (1) Stresses beyond those listed under *Absolute Maximum Ratings* may cause permanent damage to the device. These are stress ratings only, and functional operation of the device at these or any other conditions beyond those indicated under *Recommended Operating Conditions* is not implied. Exposure to absolute-maximum-rated conditions for extended periods may affect device reliability.
- (2) The input and output voltage ratings may be exceeded if the input and output current ratings are observed.

## 5.2 ESD Ratings

		VALUE	UNIT
V <sub>(ESD)</sub>	Electrostatic discharge	Human body model (HBM), per ANSI/ESDA/JEDEC JS-001 <sup>(1)</sup>	±2000
		Charged device model (CDM), per JEDEC specification JESD22-C101 <sup>(2)</sup>	±1000

- (1) JEDEC document JEP155 states that 500-V HBM allows safe manufacturing with a standard ESD control process.
- (2) JEDEC document JEP157 states that 250-V CDM allows safe manufacturing with a standard ESD control process.

## 5.3 Recommended Operating Conditions

over operating free-air temperature range (unless otherwise noted)<sup>(1)</sup>

		MIN	NOM	MAX	UNIT
V <sub>CC</sub>	Supply voltage	2		5.5	V
V <sub>IH</sub>	High-level input voltage	V <sub>CC</sub> = 2 V	1.5		V
		V <sub>CC</sub> = 3 V	2.1		
		V <sub>CC</sub> = 5.5 V	3.85		
V <sub>IL</sub>	Low-level Input voltage	V <sub>CC</sub> = 2 V		0.5	V
		V <sub>CC</sub> = 3 V		0.9	
		V <sub>CC</sub> = 5.5 V		1.65	
V <sub>I</sub>	Input voltage	0		5.5	V
V <sub>O</sub>	Output voltage	0		V <sub>CC</sub>	V
I <sub>OH</sub>	High-level output current	V <sub>CC</sub> = 2 V		-50	μA
		V <sub>CC</sub> = 3.3 V ± 0.3 V		-4	mA
		V <sub>CC</sub> = 5 V ± 0.5 V		-8	
I <sub>OL</sub>	Low-level output current	V <sub>CC</sub> = 2 V		50	μA
		V <sub>CC</sub> = 3.3 V ± 0.3 V		4	mA
		V <sub>CC</sub> = 5 V ± 0.5 V		8	
Δt/Δv	Input transition rise or fall rate	V <sub>CC</sub> = 3.3 V ± 0.3 V		100	ns/V
		V <sub>CC</sub> = 5 V ± 0.5 V		20	
T <sub>A</sub>	Operating free-air temperature	-40		125	°C

- (1) All unused inputs of the device must be held at V<sub>CC</sub> or GND to ensure proper device operation. Refer to the TI application report, *Implications of Slow or Floating CMOS Inputs*, [SCBA004](#).

## 5.4 Thermal Information

THERMAL METRIC <sup>(1)</sup>		SN74AHC595					UNIT
		BQB (WQFN)	D (SOIC)	DB (SSOP)	N (PDIP)	PW (TSSOP)	
		16 PINS	16 PINS	16 PINS	16 PINS	16 PINS	
R <sub>θJA</sub>	Junction-to-ambient thermal resistance	91.8	73	97.8	47.8	135.9	°C/W
R <sub>θJC(top)</sub>	Junction-to-case (top) thermal resistance	87.7	—	48.1	35.1	70.3	°C/W
R <sub>θJB</sub>	Junction-to-board thermal resistance	61.6	—	48.5	27.8	81.3	°C/W
ψ <sub>JT</sub>	Junction-to-top characterization parameter	11.9	—	10.0	20.1	22.5	°C/W

THERMAL METRIC <sup>(1)</sup>	SN74AHC595					UNIT
	BQB (WQFN)	D (SOIC)	DB (SSOP)	N (PDIP)	PW (TSSOP)	
	16 PINS	16 PINS	16 PINS	16 PINS	16 PINS	
$\Psi_{JB}$ Junction-to-board characterization parameter	61.4	—	47.9	27.7	80.8	°C/W
$R_{\theta JC(bot)}$ Junction-to-case (bottom) thermal resistance	39.4	—	—	—	—	°C/W

(1) For more information about traditional and new thermal metrics, see the *Semiconductor and IC Package Thermal Metrics* application report, [SPRA953](#).

### 5.5 Electrical Characteristics

over operating free-air temperature range (unless otherwise noted) <sup>(1)</sup>

PARAMETER	TEST CONDITIONS		V <sub>CC</sub>	MIN	TYP	MAX	UNIT
V <sub>OH</sub>	I <sub>OH</sub> = -50 μA	T <sub>A</sub> = 25°C	2 V	1.9	2		V
		T <sub>A</sub> = -40°C to 85°C		1.9			
		T <sub>A</sub> = -40°C to 125°C Recommended		1.9			
	I <sub>OH</sub> = -50 μA	T <sub>A</sub> = 25°C	3 V	2.9	3		
		T <sub>A</sub> = -40°C to 85°C		2.9			
		T <sub>A</sub> = -40°C to 125°C Recommended		2.9			
	I <sub>OH</sub> = -50 μA	T <sub>A</sub> = 25°C	4.5 V	4.4	4.5		
		T <sub>A</sub> = -40°C to 85°C		4.4			
		T <sub>A</sub> = -40°C to 125°C Recommended		4.4			
	I <sub>OH</sub> = -4 mA	T <sub>A</sub> = 25°C	3 V	2.58			
		T <sub>A</sub> = -40°C to 85°C		2.48			
		T <sub>A</sub> = -40°C to 125°C Recommended		2.48			
I <sub>OH</sub> = -8 mA	T <sub>A</sub> = 25°C	4.5 V	3.94				
	T <sub>A</sub> = -40°C to 85°C		3.8				
	T <sub>A</sub> = -40°C to 125°C Recommended		3.8				
V <sub>OL</sub>	I <sub>OL</sub> = 50 μA	T <sub>A</sub> = 25°C	2 V			0.1	V
		T <sub>A</sub> = -40°C to 85°C				0.1	
		T <sub>A</sub> = -40°C to 125°C Recommended				0.1	
	I <sub>OL</sub> = 50 μA	T <sub>A</sub> = 25°C	3 V			0.1	
		T <sub>A</sub> = -40°C to 85°C				0.1	
		T <sub>A</sub> = -40°C to 125°C Recommended				0.1	
	I <sub>OL</sub> = 50 μA	T <sub>A</sub> = 25°C	4.5 V			0.1	
		T <sub>A</sub> = -40°C to 85°C				0.1	
		T <sub>A</sub> = -40°C to 125°C Recommended				0.1	
	I <sub>OL</sub> = 4 mA	T <sub>A</sub> = 25°C	3 V			0.36	
		T <sub>A</sub> = -40°C to 85°C				0.44	
		T <sub>A</sub> = -40°C to 125°C Recommended				0.44	
	I <sub>OL</sub> = 8 mA	T <sub>A</sub> = 25°C	4.5 V			0.36	
		T <sub>A</sub> = -40°C to 85°C				0.44	
		T <sub>A</sub> = -40°C to 125°C Recommended				0.44	
I <sub>I</sub>	V <sub>I</sub> = 5.5 V or GND	T <sub>A</sub> = 25°C	0 V to 5.5 V			±0.1	μA
		T <sub>A</sub> = -40°C to 85°C				±1	
		T <sub>A</sub> = -40°C to 125°C Recommended				±1	
I <sub>OZ</sub>	V <sub>I</sub> = V <sub>CC</sub> or GND, V <sub>O</sub> = V <sub>CC</sub> or GND, OE = V <sub>IH</sub> or V <sub>IL</sub> .	Q <sub>A</sub> - Q <sub>H</sub>	5.5 V	T <sub>A</sub> = 25°C		±0.25	μA
				T <sub>A</sub> = -40°C to 85°C		±2.5	
				T <sub>A</sub> = -40°C to 125°C Recommended		±2.5	

over operating free-air temperature range (unless otherwise noted) <sup>(1)</sup>

PARAMETER	TEST CONDITIONS		V <sub>CC</sub>	MIN	TYP	MAX	UNIT	
I <sub>CC</sub>	V <sub>I</sub> = V <sub>CC</sub> or GND,	I <sub>O</sub> = 0	5.5 V			4	μA	
						T <sub>A</sub> = 25°C		40
						T <sub>A</sub> = -40°C to 85°C		40
C <sub>i</sub>	V <sub>I</sub> = V <sub>CC</sub> or GND	T <sub>A</sub> = 25°C	5 V			3	pF	
						T <sub>A</sub> = -40°C TO 85°C		10
						T <sub>A</sub> = -40°C to 125°C Recommended		
C <sub>O</sub>	V <sub>O</sub> = V <sub>CC</sub> or GND,	T <sub>A</sub> = 25°C	5 V		5.5		pF	

(1) On products compliant to MIL-PRF-38535, this parameter is not production tested at V<sub>CC</sub> = 0 V.

### 5.6 Timing Requirements: V<sub>CC</sub> = 3.3 V ± 0.3 V

over recommended operating free-air temperature range (unless otherwise noted)

			MIN	MAX	UNIT
t <sub>w</sub>	Pulse duration	SRCLK high or low	T <sub>A</sub> = 25°C	5	ns
			T <sub>A</sub> = -40°C to 85°C	5	
			T <sub>A</sub> = -40°C to 125°C Recommended	6	
	RCLK high or low	T <sub>A</sub> = 25°C	5		
		T <sub>A</sub> = -40°C to 85°C	5		
		T <sub>A</sub> = -40°C to 125°C Recommended	6		
	SRCLR low	T <sub>A</sub> = 25°C	5		
		T <sub>A</sub> = -40°C to 85°C	5		
		T <sub>A</sub> = -40°C to 125°C Recommended	6.5		
t <sub>su</sub>	Set-up time	SER before SRCLK↑	T <sub>A</sub> = 25°C	3.5	ns
			T <sub>A</sub> = -40°C to 85°C	3.5	
			T <sub>A</sub> = -40°C to 125°C Recommended	4.5	
	SRCLK↑ before RCLK↑ <sup>(1)</sup>	T <sub>A</sub> = 25°C	8		
		T <sub>A</sub> = -40°C to 85°C	8.5		
		T <sub>A</sub> = -40°C to 125°C Recommended	9.5		
	SRCLR low before RCLK↑	T <sub>A</sub> = 25°C	8		
		T <sub>A</sub> = -40°C to 85°C	9		
		T <sub>A</sub> = -40°C to 125°C Recommended	10		
	SRCLR high (inactive) before SRCLK↑	T <sub>A</sub> = 25°C	3		
		T <sub>A</sub> = -40°C to 85°C	3		
		T <sub>A</sub> = -40°C to 125°C Recommended	4		
t <sub>h</sub>	Hold time	SER after SRCLK↑	T <sub>A</sub> = 25°C	1.5	ns
			T <sub>A</sub> = -40°C to 85°C	1.5	
			T <sub>A</sub> = -40°C to 125°C Recommended	2.5	

(1) This set-up time allows the storage register to receive stable data from the shift register. The clocks can be tied together, in which case the shift register is one clock pulse ahead of the storage register.

### 5.7 Timing Requirements: $V_{CC} = 5\text{ V} \pm 0.5\text{ V}$

			MIN	NOM	MAX	UNIT
$t_W$	Pulse duration	SRCLK high or low	$T_A = 25^\circ\text{C}$	5		ns
			$T_A = -40^\circ\text{C to } 85^\circ\text{C}$	5		
			$T_A = -40^\circ\text{C to } 125^\circ\text{C Recommended}$	6		
	RCLK high or low	$T_A = 25^\circ\text{C}$	5			
		$T_A = -40^\circ\text{C to } 85^\circ\text{C}$	5			
		$T_A = -40^\circ\text{C to } 125^\circ\text{C Recommended}$	6			
	SRCLR low	$T_A = 25^\circ\text{C}$	5			
		$T_A = -40^\circ\text{C to } 85^\circ\text{C}$	5			
		$T_A = -40^\circ\text{C to } 125^\circ\text{C Recommended}$	6.2			
$t_{su}$	Set-up time	SER before SRCLK $\uparrow$	$T_A = 25^\circ\text{C}$	3		ns
			$T_A = -40^\circ\text{C to } 85^\circ\text{C}$	3		
			$T_A = -40^\circ\text{C to } 125^\circ\text{C Recommended}$	4		
	SRCLK $\uparrow$ before RCLK $\uparrow$ (1)	$T_A = 25^\circ\text{C}$	5			
		$T_A = -40^\circ\text{C to } 85^\circ\text{C}$	5			
		$T_A = -40^\circ\text{C to } 125^\circ\text{C Recommended}$	6			
	SRCLR low before RCLK $\uparrow$	$T_A = 25^\circ\text{C}$	5			
		$T_A = -40^\circ\text{C to } 85^\circ\text{C}$	5			
		$T_A = -40^\circ\text{C to } 125^\circ\text{C Recommended}$	6			
	SRCLR high (inactive) before SRCLK $\uparrow$	$T_A = 25^\circ\text{C}$	2.5			
		$T_A = -40^\circ\text{C to } 85^\circ\text{C}$	2.5			
		$T_A = -40^\circ\text{C to } 125^\circ\text{C Recommended}$	3.5			
$t_h$	Hold time	SER after SRCLK $\uparrow$	$T_A = 25^\circ\text{C}$	2		ns
			$T_A = -40^\circ\text{C to } 85^\circ\text{C}$	2		
			$T_A = -40^\circ\text{C to } 125^\circ\text{C Recommended}$	3		

(1) This set-up time allows the storage register to receive stable data from the shift register. The clocks can be tied together, in which case the shift register is one clock pulse ahead of the storage register.

### 5.8 Switching Characteristics: $V_{CC} = 3.3\text{ V} \pm 0.3\text{ V}$

over operating free-air temperature range (unless otherwise noted)

PARAMETER	FROM (INPUT)	TO (OUTPUT)	LOAD CAPACITANCE	TEST CONDITIONS	MIN	TYP	MAX	UNIT
$f_{max}$			$C_L = 15\text{ pF}$	$T_A = 25^\circ\text{C}$	80 <sup>(1)</sup>	120 <sup>(1)</sup>	MHz	
				$T_A = -40^\circ\text{C to } 85^\circ\text{C}$	70			
				$T_A = -40^\circ\text{C to } 125^\circ\text{C Recommended}$	60			
			$C_L = 50\text{ pF}$	$T_A = 25^\circ\text{C}$	55	105		
				$T_A = -40^\circ\text{C to } 85^\circ\text{C}$	50			
				$T_A = -40^\circ\text{C to } 125^\circ\text{C Recommended}$	40			
$t_{PLH}$	RCLK	$Q_A - Q_H$	$C_L = 15\text{ pF}$	$T_A = 25^\circ\text{C}$		6 <sup>(1)</sup>	11.9 <sup>(1)</sup>	ns
				$T_A = -40^\circ\text{C to } 85^\circ\text{C}$	1		13.5	
				$T_A = -40^\circ\text{C to } 125^\circ\text{C Recommended}$	1		14.9	
$t_{PHL}$	RCLK	$Q_A - Q_H$	$C_L = 15\text{ pF}$	$T_A = 25^\circ\text{C}$		6 <sup>(1)</sup>	11.9 <sup>(1)</sup>	ns
				$T_A = -40^\circ\text{C to } 85^\circ\text{C}$	1		13.5	
				$T_A = -40^\circ\text{C to } 125^\circ\text{C Recommended}$	1		14.9	
$t_{PLH}$	SRCLK	$Q_H$	$C_L = 15\text{ pF}$	$T_A = 25^\circ\text{C}$		6.6 <sup>(1)</sup>	13 <sup>(1)</sup>	ns
				$T_A = -40^\circ\text{C to } 85^\circ\text{C}$	1		15	
				$T_A = -40^\circ\text{C to } 125^\circ\text{C Recommended}$	1		16.4	
$t_{PHL}$	SRCLK	$Q_H$	$C_L = 15\text{ pF}$	$T_A = 25^\circ\text{C}$		6.6 <sup>(1)</sup>	13 <sup>(1)</sup>	ns
				$T_A = -40^\circ\text{C to } 85^\circ\text{C}$	1		15	
				$T_A = -40^\circ\text{C to } 125^\circ\text{C Recommended}$	1		16.4	

over operating free-air temperature range (unless otherwise noted)

PARAMETER	FROM (INPUT)	TO (OUTPUT)	LOAD CAPACITANCE	TEST CONDITIONS	MIN	TYP	MAX	UNIT
t <sub>PHL</sub>	SRCLR	Q <sub>H</sub>	C <sub>L</sub> = 15 pF	T <sub>A</sub> = 25°C		6.2 <sup>(1)</sup>	12.8 <sup>(1)</sup>	ns
				T <sub>A</sub> = -40°C to 85°C		1	13.7	
				T <sub>A</sub> = -40°C to 125°C Recommended		1	15	
t <sub>PZH</sub>	OE	Q <sub>A</sub> – Q <sub>H</sub>	C <sub>L</sub> = 15 pF	T <sub>A</sub> = 25°C		6 <sup>(1)</sup>	11.5 <sup>(1)</sup>	ns
				T <sub>A</sub> = -40°C to 85°C		1	13.5	
				T <sub>A</sub> = -40°C to 125°C Recommended		1	14.9	
t <sub>PZL</sub>	OE	Q <sub>A</sub> – Q <sub>H</sub>	C <sub>L</sub> = 15 pF	T <sub>A</sub> = 25°C		7.8 <sup>(1)</sup>	11.5 <sup>(1)</sup>	ns
				T <sub>A</sub> = -40°C to 85°C		1	13.5	
				T <sub>A</sub> = -40°C to 125°C Recommended		1	14.9	
t <sub>PLH</sub>	RCLK	Q <sub>A</sub> – Q <sub>H</sub>	C <sub>L</sub> = 50 pF	T <sub>A</sub> = 25°C		7.9	15.4	ns
				T <sub>A</sub> = -40°C to 85°C		1	17	
				T <sub>A</sub> = -40°C to 125°C Recommended		1	18.6	
t <sub>PHL</sub>	RCLK	Q <sub>A</sub> – Q <sub>H</sub>	C <sub>L</sub> = 50 pF	T <sub>A</sub> = 25°C		7.9	15.4	ns
				T <sub>A</sub> = -40°C to 85°C		1	17	
				T <sub>A</sub> = -40°C to 125°C Recommended		1	18.6	
t <sub>PLH</sub>	SRCLK	Q <sub>H</sub>	C <sub>L</sub> = 50 pF	T <sub>A</sub> = 25°C		9.2	16.5	ns
				T <sub>A</sub> = -40°C to 85°C		1	18.5	
				T <sub>A</sub> = -40°C to 125°C Recommended		1	20	
t <sub>PHL</sub>	SRCLK	Q <sub>H</sub>	C <sub>L</sub> = 50 pF	T <sub>A</sub> = 25°C		9.2	16.5	ns
				T <sub>A</sub> = -40°C to 85°C		1	18.5	
				T <sub>A</sub> = -40°C to 125°C Recommended		1	20	
t <sub>PHL</sub>	SRCLR	Q <sub>H</sub>	C <sub>L</sub> = 50 pF	T <sub>A</sub> = 25°C		9	16.3	ns
				T <sub>A</sub> = -40°C to 85°C		1	17.2	
				T <sub>A</sub> = -40°C to 125°C Recommended		1	18.7	
t <sub>PZH</sub>	OE	Q <sub>A</sub> – Q <sub>H</sub>	C <sub>L</sub> = 50 pF	T <sub>A</sub> = 25°C		7.8	15	ns
				T <sub>A</sub> = -40°C to 85°C		1	17	
				T <sub>A</sub> = -40°C to 125°C Recommended		1	18.6	
t <sub>PZL</sub>	OE	Q <sub>A</sub> – Q <sub>H</sub>	C <sub>L</sub> = 50 pF	T <sub>A</sub> = 25°C		9.6	15	ns
				T <sub>A</sub> = -40°C to 85°C		1	17	
				T <sub>A</sub> = -40°C to 125°C Recommended		1	18.6	
t <sub>PHZ</sub>	OE	Q <sub>A</sub> – Q <sub>H</sub>	C <sub>L</sub> = 50 pF	T <sub>A</sub> = 25°C		8.1	15.7	ns
				T <sub>A</sub> = -40°C to 85°C		1	16.2	
				T <sub>A</sub> = -40°C to 125°C Recommended		1	17.4	
t <sub>PLZ</sub>	OE	Q <sub>A</sub> – Q <sub>H</sub>	C <sub>L</sub> = 50 pF	T <sub>A</sub> = 25°C		9.3	15.7	ns
				T <sub>A</sub> = -40°C to 85°C		1	16.2	
				T <sub>A</sub> = -40°C to 125°C Recommended		1	17.4	

(1) On products compliant to MIL-PRF-38535, this parameter is not production tested.

### 5.9 Switching Characteristics: $V_{CC} = 5 V \pm 0.5 V$

over operating free-air temperature range (unless otherwise noted)

PARAMETER	FROM (INPUT)	TO (OUTPUT)	LOAD CAPACITANCE	TEST CONDITIONS	MIN	TYP	MAX	UNIT
$f_{max}$			$C_L = 15 \text{ pF}$	$T_A = 25^\circ\text{C}$	135 <sup>(1)</sup>	170 <sup>(1)</sup>		MHz
				$T_A = -40^\circ\text{C to } 85^\circ\text{C}$	115			
			$C_L = 50 \text{ pF}$	$T_A = 25^\circ\text{C}$	95	140		
				$T_A = -40^\circ\text{C to } 85^\circ\text{C}$	85			
$t_{PLH}$	RCLK	$Q_A - Q_H$	$C_L = 15 \text{ pF}$	$T_A = 25^\circ\text{C}$		4.3 <sup>(1)</sup>	7.4 <sup>(1)</sup>	ns
				$T_A = -40^\circ\text{C to } 85^\circ\text{C}$	1		8.5	
$t_{PHL}$	RCLK	$Q_A - Q_H$	$C_L = 15 \text{ pF}$	$T_A = 25^\circ\text{C}$		4.3 <sup>(1)</sup>	7.4 <sup>(1)</sup>	ns
				$T_A = -40^\circ\text{C to } 85^\circ\text{C}$	1		8.5	
$t_{PLH}$	SRCLK	$Q_H$	$C_L = 15 \text{ pF}$	$T_A = 25^\circ\text{C}$		4.5 <sup>(1)</sup>	8.2 <sup>(1)</sup>	ns
				$T_A = -40^\circ\text{C to } 85^\circ\text{C}$	1		9.4	
$t_{PHL}$	SRCLK	$Q_H$	$C_L = 15 \text{ pF}$	$T_A = 25^\circ\text{C}$		4.5 <sup>(1)</sup>	8.2 <sup>(1)</sup>	ns
				$T_A = -40^\circ\text{C to } 85^\circ\text{C}$	1		9.4	
$t_{PHL}$	$\overline{\text{SRCLR}}$	$Q_H$	$C_L = 15 \text{ pF}$	$T_A = 25^\circ\text{C}$		4.5 <sup>(1)</sup>	8 <sup>(1)</sup>	ns
				$T_A = -40^\circ\text{C to } 85^\circ\text{C}$	1		9.1	
$t_{PZH}$	$\overline{\text{OE}}$	$Q_A - Q_H$	$C_L = 15 \text{ pF}$	$T_A = 25^\circ\text{C}$		4.3 <sup>(1)</sup>	8.6 <sup>(1)</sup>	ns
				$T_A = -40^\circ\text{C to } 85^\circ\text{C}$	1		10	
$t_{PZL}$	$\overline{\text{OE}}$	$Q_A - Q_H$	$C_L = 15 \text{ pF}$	$T_A = 25^\circ\text{C}$		5.4 <sup>(1)</sup>	8.6 <sup>(1)</sup>	ns
				$T_A = -40^\circ\text{C to } 85^\circ\text{C}$	1		10	
$t_{PLH}$	RCLK	$Q_A - Q_H$	$C_L = 50 \text{ pF}$	$T_A = 25^\circ\text{C}$		5.6	9.4	ns
				$T_A = -40^\circ\text{C to } 85^\circ\text{C}$	1		10.5	
$t_{PHL}$	RCLK	$Q_A - Q_H$	$C_L = 50 \text{ pF}$	$T_A = 25^\circ\text{C}$		5.6	9.4	ns
				$T_A = -40^\circ\text{C to } 85^\circ\text{C}$	1		10.5	
$t_{PLH}$	SRCLK	$Q_H$	$C_L = 50 \text{ pF}$	$T_A = 25^\circ\text{C}$		6.4	10.2	ns
				$T_A = -40^\circ\text{C to } 85^\circ\text{C}$	1		11.4	
$t_{PHL}$	SRCLK	$Q_H$	$C_L = 50 \text{ pF}$	$T_A = 25^\circ\text{C}$		6.4	10.2	ns
				$T_A = -40^\circ\text{C to } 85^\circ\text{C}$	1		11.4	
$t_{PHL}$	$\overline{\text{SRCLR}}$	$Q_H$	$C_L = 50 \text{ pF}$	$T_A = 25^\circ\text{C}$		6.4	10	ns
				$T_A = -40^\circ\text{C to } 85^\circ\text{C}$	1		11.1	
$t_{PZH}$	$\overline{\text{OE}}$	$Q_A - Q_H$	$C_L = 50 \text{ pF}$	$T_A = 25^\circ\text{C}$		5.7	10.6	ns
				$T_A = -40^\circ\text{C to } 85^\circ\text{C}$	1		12	
$t_{PZL}$	$\overline{\text{OE}}$	$Q_A - Q_H$	$C_L = 50 \text{ pF}$	$T_A = 25^\circ\text{C}$		6.8	10.6	ns
				$T_A = -40^\circ\text{C to } 85^\circ\text{C}$	1		12	
$t_{PHZ}$	$\overline{\text{OE}}$	$Q_A - Q_H$	$C_L = 50 \text{ pF}$	$T_A = 25^\circ\text{C}$		3.5	10.3	ns
				$T_A = -40^\circ\text{C to } 85^\circ\text{C}$	1		11	
$t_{PLZ}$	$\overline{\text{OE}}$	$Q_A - Q_H$	$C_L = 50 \text{ pF}$	$T_A = 25^\circ\text{C}$		3.4	10.3	ns
				$T_A = -40^\circ\text{C to } 85^\circ\text{C}$	1		11	

(1) On products compliant to MIL-PRF-38535, this parameter is not production tested.

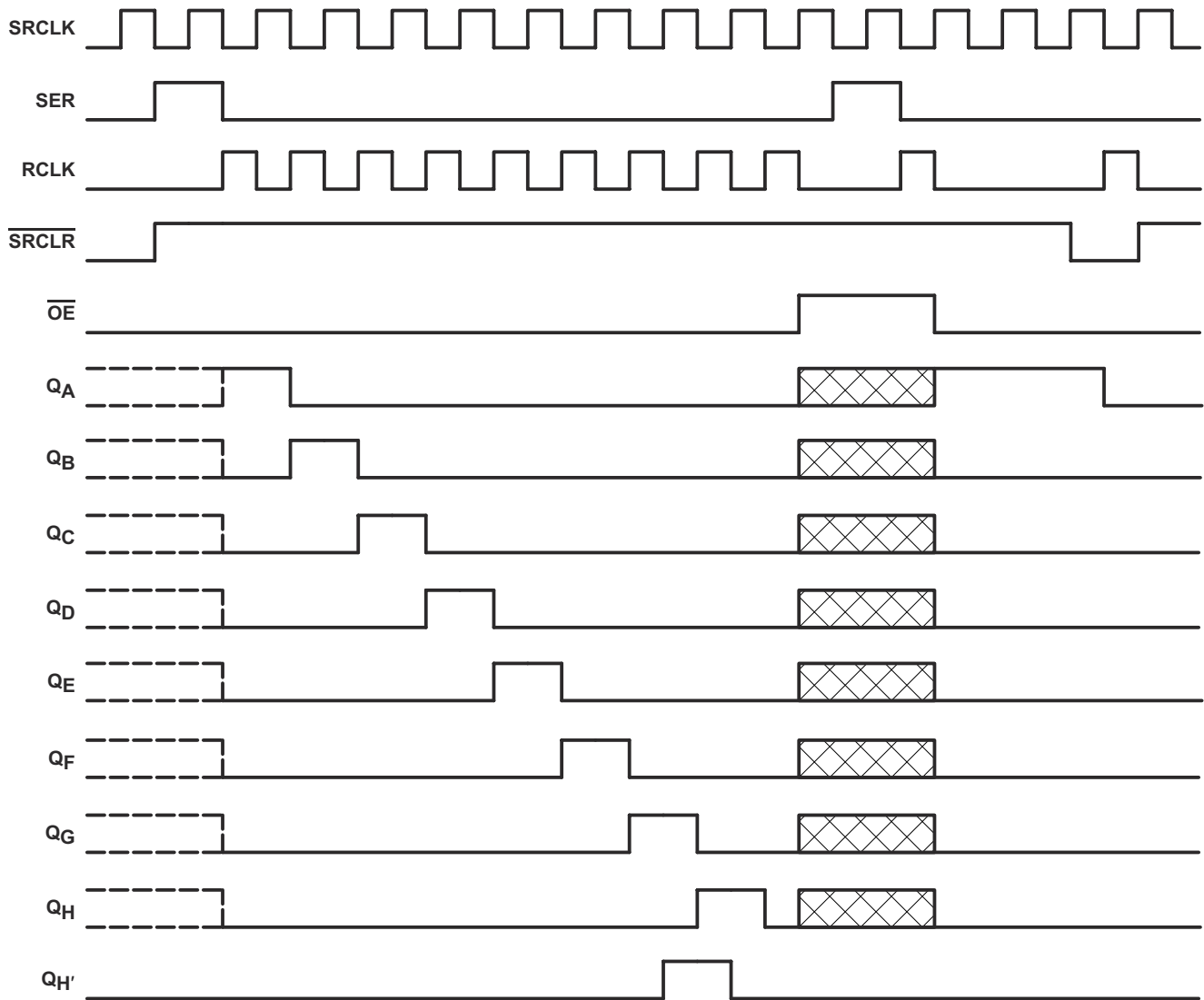

NOTE:  implies that the output is in 3-State mode.

图 5-1. Timing Diagram

### 5.10 Operating Characteristics

$V_{CC} = 5\text{ V}$ ,  $T_A = 25^\circ\text{C}$

PARAMETER		TEST CONDITIONS	TYP	UNIT
$C_{pd}$	Power dissipation capacitance	No load, $f = 1\text{ MHz}$	25.2	pF

### 5.11 Typical Characteristics

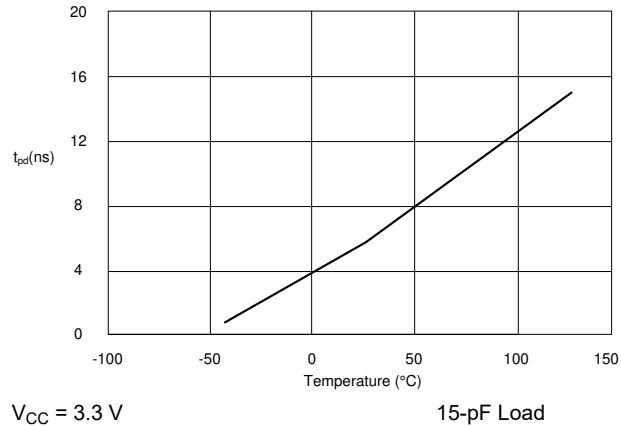

**图 5-2. SN74AHC595 RCLK to Q TPD vs Temperature**

## 6 Parameter Measurement Information

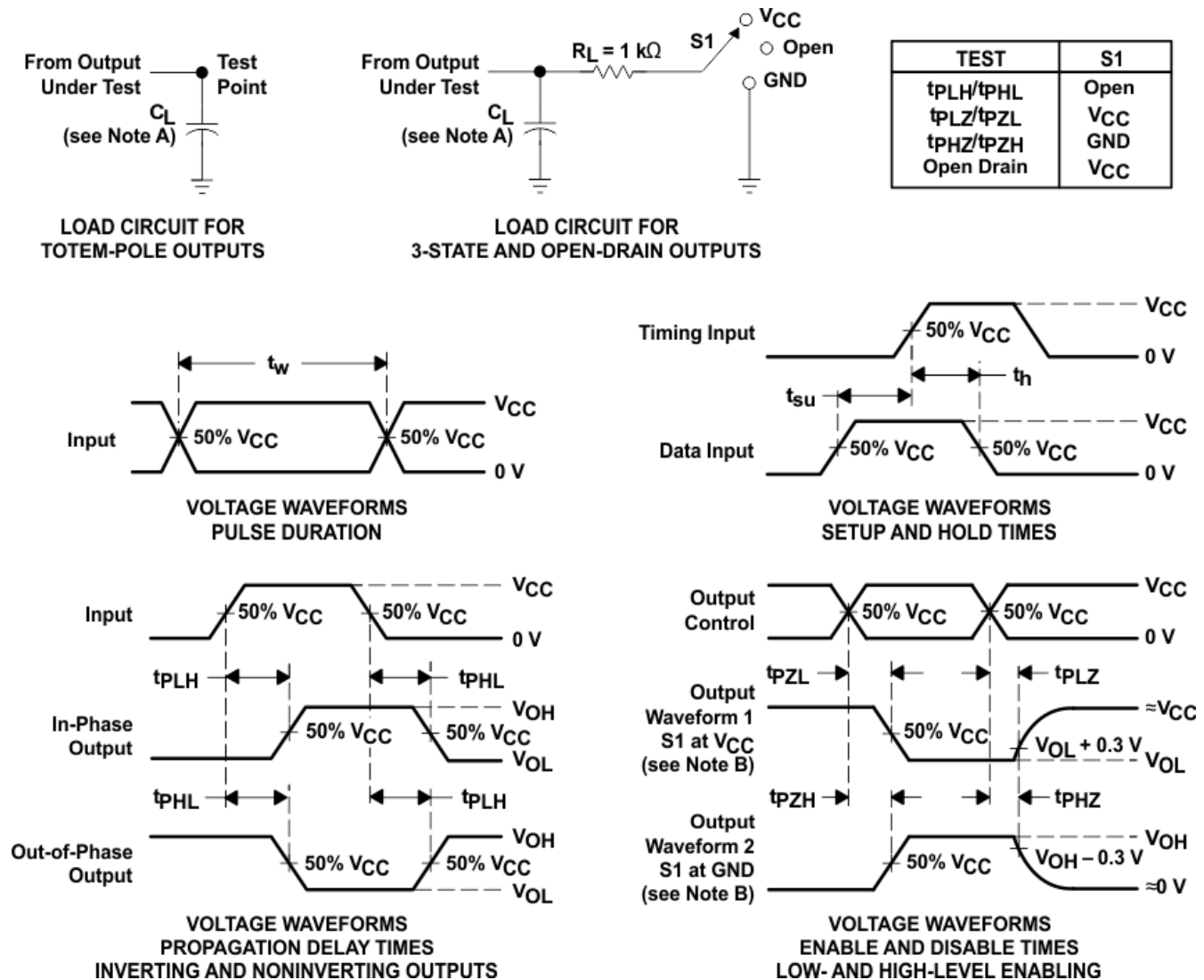

- A.  $C_L$  includes probe and jig capacitance.
- B. Waveform 1 is for an output with internal conditions such that the output is low except when disabled by the output control. Waveform 2 is for an output with internal conditions such that the output is high except when disabled by the output control.
- C. All input pulses are supplied by generators having the following characteristics: PRR  $\leq 1\text{ MHz}$ ,  $Z_O = 50\ \Omega$ ,  $t_r \leq 3\text{ ns}$ ,  $t_f \leq 3\text{ ns}$ .
- D. The outputs are measured one at a time with one input transition per measurement.
- E. All parameters and waveforms are not applicable to all devices.

**图 6-1. Load Circuit and Voltage Waveforms**

## 7 Detailed Description

### 7.1 Overview

The SN74AHC595 device is part of the AHC family of logic devices intended for CMOS applications. The SN74HC595 device is an 8-bit shift register that feeds an 8-bit D-type storage register.

Both the shift-register clock (SRCLK) and storage-register clock (RCLK) are positive-edge triggered. If both clocks are connected together, the shift register is always one clock pulse ahead of the storage register.

### 7.2 Functional Block Diagram

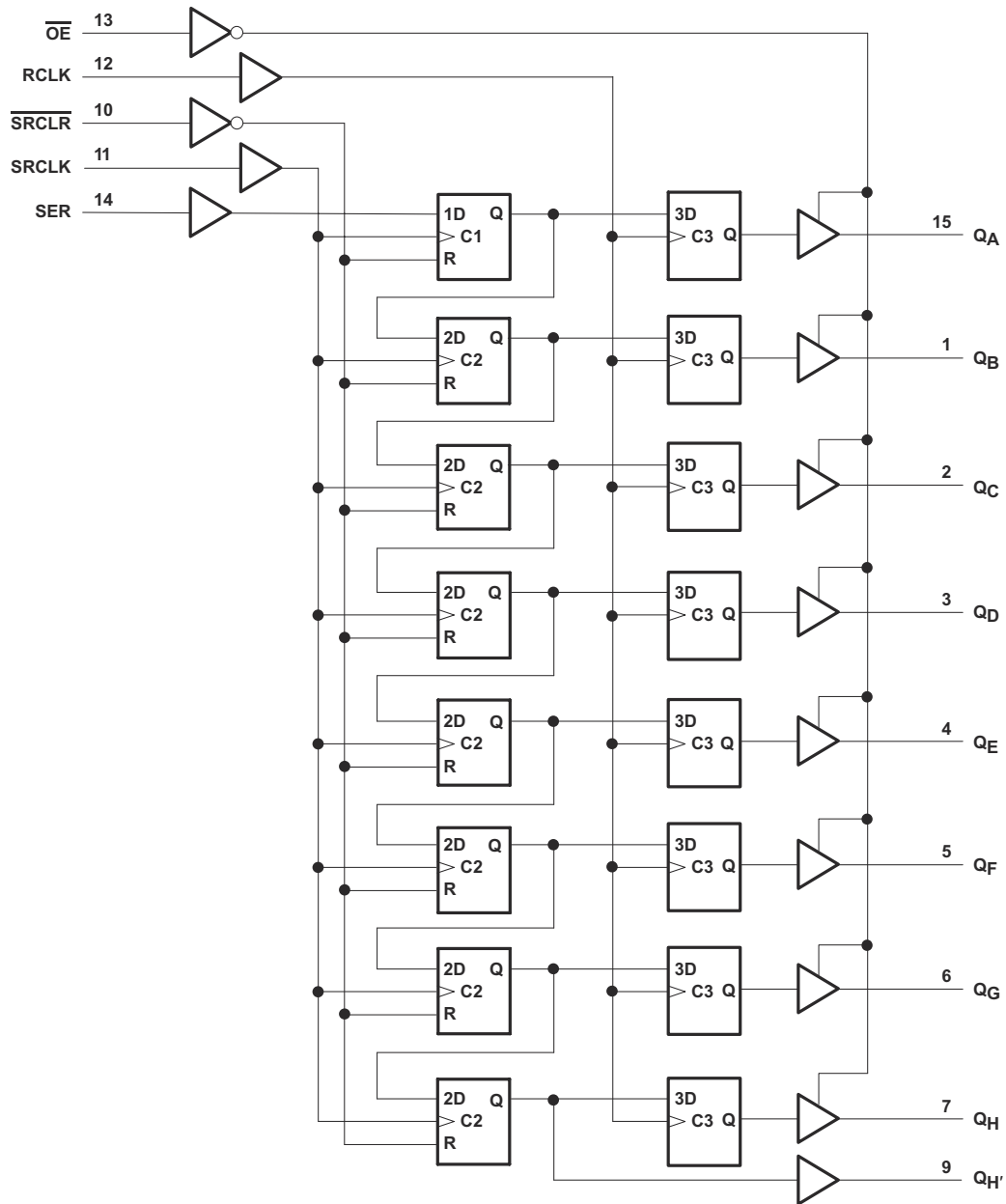

### 7.3 Feature Description

The SN74AHC595 device is an 8-bit serial-in, parallel-out shift registers that have a wide operating voltage range from 2 V to 5.5 V and a low current consumption of 40- $\mu$ A (max)  $I_{CC}$ .

### 7.4 Device Functional Modes

表 7-1. Function Table

INPUTS					FUNCTION
SER	SRCLK	SRCLR	RCLK	OE	
X	X	X	X	H	Outputs $Q_A$ – $Q_H$ are disabled.
X	X	X	X	L	Outputs $Q_A$ – $Q_H$ are enabled.
X	X	L	X	X	Shift register is cleared.
L	↑	H	X	X	First stage of the shift register goes low. Other stages store the data of previous stage, respectively.
H	↑	H	X	X	First stage of the shift register goes high. Other stages store the data of previous stage, respectively.
X	X	X	↑	X	Shift-register data is stored into the storage register.

## 8 Application and Implementation

### 备注

以下应用部分中的信息不属于 TI 器件规格的范围，TI 不担保其准确性和完整性。TI 的客户应负责确定器件是否适用于其应用。客户应验证并测试其设计，以确保系统功能。

### 8.1 Application Information

The SN74AHC595 device is a low-drive CMOS device that can be used for a multitude of bus-interface type applications where output ringing is a concern. The low drive and slow edge rates minimize overshoot and undershoot on the outputs. 图 8-1 shows an application where eight LEDs are used to visualize the data bits contained within the shift register.

## 8.2 Typical Application

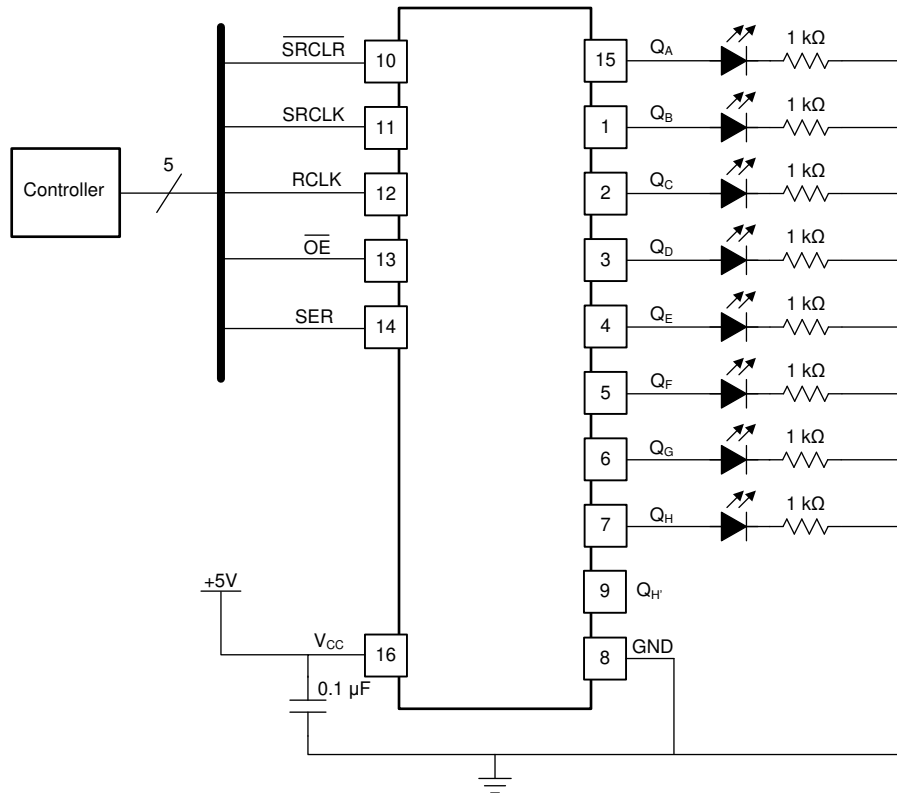

**图 8-1. Shift Register Display of 8 bits**

### 8.2.1 Design Requirements

This device uses CMOS technology and has balanced output drive. Care must be taken to avoid bus contention because it can drive currents that would exceed maximum limits. The high drive will also create fast edges into light loads, so routing and load conditions must be considered to prevent ringing.

### 8.2.2 Detailed Design Procedure

- Recommended input conditions:
  - Specified high and low levels. See ( $V_{IH}$  and  $V_{IL}$ ) in the [Recommended Operating Conditions](#) table.
  - Specified high and low levels. See ( $V_{IH}$  and  $V_{IL}$ ) in the [Recommended Operating Conditions](#) table.
  - Inputs are overvoltage tolerant allowing them to go as high as 6.0 V at any valid  $V_{CC}$
- Recommend output conditions:
  - Load currents must not exceed 25 mA per output and 75 mA total for the part
  - Outputs must not be pulled above  $V_{CC}$



### 8.3 Power Supply Recommendations

The power supply can be any voltage between the MIN and MAX supply-voltage rating located in the [Recommended Operating Conditions](#) table.

Each  $V_{CC}$  pin must have a good bypass capacitor to prevent power disturbance. For devices with a single supply, 0.1- $\mu\text{F}$  capacitor is recommended; if there are multiple  $V_{CC}$  pins, then a 0.01- $\mu\text{F}$  or a 0.022- $\mu\text{F}$  capacitor is recommended for each power pin. It is acceptable to parallel multiple bypass capacitors to reject different frequencies of noise. A 0.1- $\mu\text{F}$  and a 1- $\mu\text{F}$  capacitor are commonly used in parallel. The bypass capacitor must be installed as close to the power pin as possible for best results.

### 8.4 Layout

#### 8.4.1 Layout Guidelines

When using multiple-bit logic devices, inputs must never float.

In many cases, functions or parts of functions of digital logic devices are unused, for example, when only two inputs of a triple-input AND gate are used or only 3 of the 4 buffer gates are used. Such input pins must **not** be left unconnected because the undefined voltages at the outside connections results in undefined operational states. [图 8-3](#) specifies the rules that must be observed under all circumstances. All unused inputs of digital logic devices must be connected to a high or low bias to prevent them from floating. The logic level that must be applied to any particular unused input depends on the function of the device. Generally, these unused inputs will be tied to GND or  $V_{CC}$ , whichever makes more sense or is more convenient. It is generally acceptable to float outputs, unless the part is a transceiver. If the transceiver has an output-enable pin, it will disable the output section of the part when asserted. This will not disable the input section of the I/Os, so they cannot float when disabled.

#### 8.4.2 Layout Example



图 8-3. Example Layout for the SN74AHC595

## 9 Device and Documentation Support

### 9.1 Documentation Support

#### 9.1.1 Related Documentation

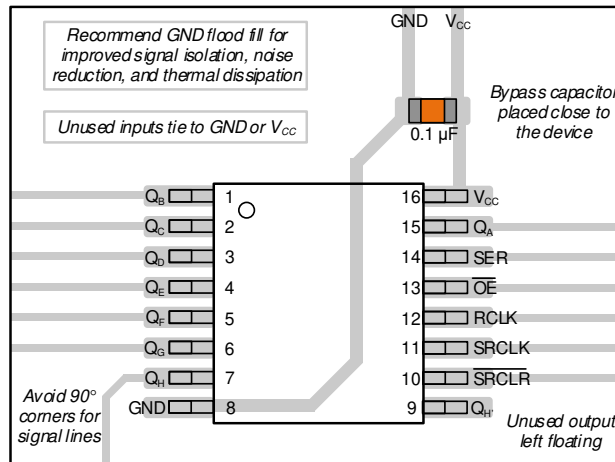
For related documentation, see the following:

*Implications of Slow or Floating CMOS Inputs*, [SCBA004](#)

### 9.2 接收文档更新通知

要接收文档更新通知，请导航至 [ti.com](#) 上的器件产品文件夹。点击 [通知](#) 进行注册，即可每周接收产品信息更改摘要。有关更改的详细信息，请查看任何已修订文档中包含的修订历史记录。

### 9.3 支持资源

TI E2E™ 中文支持论坛是工程师的重要参考资料，可直接从专家处获得快速、经过验证的解答和设计帮助。搜索现有解答或提出自己的问题，获得所需的快速设计帮助。

链接的内容由各个贡献者“按原样”提供。这些内容并不构成 TI 技术规范，并且不一定反映 TI 的观点；请参阅 TI 的使用条款。

### 9.4 Trademarks

TI E2E™ is a trademark of Texas Instruments.

所有商标均为其各自所有者的财产。

### 9.5 静电放电警告



静电放电 (ESD) 会损坏这个集成电路。德州仪器 (TI) 建议通过适当的预防措施处理所有集成电路。如果不遵守正确的处理和安装程序，可能会损坏集成电路。

ESD 的损坏小至导致微小的性能降级，大至整个器件故障。精密的集成电路可能更容易受到损坏，这是因为非常细微的参数更改都可能会导致器件与其发布的规格不相符。

### 9.6 术语表

TI 术语表 本术语表列出并解释了术语、首字母缩略词和定义。

## 10 Revision History

注：以前版本的页码可能与当前版本的页码不同

Changes from Revision L (March 2024) to Revision M (April 2024)	Page
• Updated thermal values for PW package from RθJA = 106.1 to 135.9, RθJC(top) = 40.8 to 70.3, RθJB = 51.1 to 81.3, ΨJT = 3.8 to 22.5, ΨJB = 50.6 to 80.8, all values in °C/W.....	4
• Added <i>Typical Characteristics</i> .....	11
• Updated <i>Layout Example</i> .....	17

Changes from Revision K (September 2015) to Revision L (March 2024)	Page
• 删除了对机器型号的引用，将器件信息更改为封装信息，并在表中添加了封装尺寸.....	1
• 向封装信息表、引脚配置和功能部分和热性能信息表中添加了 BQB 封装.....	1

## 11 Mechanical, Packaging, and Orderable Information

The following pages include mechanical, packaging, and orderable information. This information is the most current data available for the designated devices. This data is subject to change without notice and revision of this document. For browser-based versions of this data sheet, refer to the left-hand navigation.

**PACKAGING INFORMATION**

Orderable Device	Status (1)	Package Type	Package Drawing	Pins	Package Qty	Eco Plan (2)	Lead finish/ Ball material (6)	MSL Peak Temp (3)	Op Temp (°C)	Device Marking (4/5)	Samples
SN74AHC595BQBR	ACTIVE	WQFN	BQB	16	3000	RoHS & Green	NIPDAU	Level-1-260C-UNLIM	-40 to 125	AHC595	<a href="#">Samples</a>
SN74AHC595D	OBSOLETE	SOIC	D	16		TBD	Call TI	Call TI	-40 to 125	AHC595	
SN74AHC595DBR	ACTIVE	SSOP	DB	16	2000	RoHS & Green	NIPDAU	Level-1-260C-UNLIM	-40 to 125	HA595	<a href="#">Samples</a>
SN74AHC595DR	ACTIVE	SOIC	D	16	2500	RoHS & Green	NIPDAU	Level-1-260C-UNLIM	-40 to 125	AHC595	<a href="#">Samples</a>
SN74AHC595N	ACTIVE	PDIP	N	16	25	RoHS & Green	NIPDAU	N / A for Pkg Type	-40 to 125	SN74AHC595N	<a href="#">Samples</a>
SN74AHC595PW	OBSOLETE	TSSOP	PW	16		TBD	Call TI	Call TI	-40 to 125	HA595	
SN74AHC595PWR	ACTIVE	TSSOP	PW	16	2000	RoHS & Green	NIPDAU   SN	Level-1-260C-UNLIM	-40 to 125	HA595	<a href="#">Samples</a>
SN74AHC595PWRG4	ACTIVE	TSSOP	PW	16	2000	RoHS & Green	NIPDAU	Level-1-260C-UNLIM	-40 to 125	HA595	<a href="#">Samples</a>

(1) The marketing status values are defined as follows:

**ACTIVE:** Product device recommended for new designs.

**LIFEBUY:** TI has announced that the device will be discontinued, and a lifetime-buy period is in effect.

**NRND:** Not recommended for new designs. Device is in production to support existing customers, but TI does not recommend using this part in a new design.

**PREVIEW:** Device has been announced but is not in production. Samples may or may not be available.

**OBSOLETE:** TI has discontinued the production of the device.

(2) **RoHS:** TI defines "RoHS" to mean semiconductor products that are compliant with the current EU RoHS requirements for all 10 RoHS substances, including the requirement that RoHS substance do not exceed 0.1% by weight in homogeneous materials. Where designed to be soldered at high temperatures, "RoHS" products are suitable for use in specified lead-free processes. TI may reference these types of products as "Pb-Free".

**RoHS Exempt:** TI defines "RoHS Exempt" to mean products that contain lead but are compliant with EU RoHS pursuant to a specific EU RoHS exemption.

**Green:** TI defines "Green" to mean the content of Chlorine (Cl) and Bromine (Br) based flame retardants meet JS709B low halogen requirements of <=1000ppm threshold. Antimony trioxide based flame retardants must also meet the <=1000ppm threshold requirement.

(3) MSL, Peak Temp. - The Moisture Sensitivity Level rating according to the JEDEC industry standard classifications, and peak solder temperature.

(4) There may be additional marking, which relates to the logo, the lot trace code information, or the environmental category on the device.

(5) Multiple Device Markings will be inside parentheses. Only one Device Marking contained in parentheses and separated by a "-" will appear on a device. If a line is indented then it is a continuation of the previous line and the two combined represent the entire Device Marking for that device.

<sup>(6)</sup> Lead finish/Ball material - Orderable Devices may have multiple material finish options. Finish options are separated by a vertical ruled line. Lead finish/Ball material values may wrap to two lines if the finish value exceeds the maximum column width.

**Important Information and Disclaimer:**The information provided on this page represents TI's knowledge and belief as of the date that it is provided. TI bases its knowledge and belief on information provided by third parties, and makes no representation or warranty as to the accuracy of such information. Efforts are underway to better integrate information from third parties. TI has taken and continues to take reasonable steps to provide representative and accurate information but may not have conducted destructive testing or chemical analysis on incoming materials and chemicals. TI and TI suppliers consider certain information to be proprietary, and thus CAS numbers and other limited information may not be available for release.

In no event shall TI's liability arising out of such information exceed the total purchase price of the TI part(s) at issue in this document sold by TI to Customer on an annual basis.

**OTHER QUALIFIED VERSIONS OF SN74AHC595 :**

- Automotive : [SN74AHC595-Q1](#)

NOTE: Qualified Version Definitions:

- Automotive - Q100 devices qualified for high-reliability automotive applications targeting zero defects

**TAPE AND REEL INFORMATION**

**QUADRANT ASSIGNMENTS FOR PIN 1 ORIENTATION IN TAPE**



\*All dimensions are nominal

Device	Package Type	Package Drawing	Pins	SPQ	Reel Diameter (mm)	Reel Width W1 (mm)	A0 (mm)	B0 (mm)	K0 (mm)	P1 (mm)	W (mm)	Pin1 Quadrant
SN74AHC595BQBR	WQFN	BQB	16	3000	180.0	12.4	2.8	3.8	1.2	4.0	12.0	Q1
SN74AHC595DBR	SSOP	DB	16	2000	330.0	16.4	8.35	6.6	2.4	12.0	16.0	Q1
SN74AHC595DR	SOIC	D	16	2500	330.0	16.4	6.5	10.3	2.1	8.0	16.0	Q1
SN74AHC595PWR	TSSOP	PW	16	2000	330.0	12.4	6.9	5.6	1.6	8.0	12.0	Q1
SN74AHC595PWRG4	TSSOP	PW	16	2000	330.0	12.4	6.9	5.6	1.6	8.0	12.0	Q1

**TAPE AND REEL BOX DIMENSIONS**

\*All dimensions are nominal

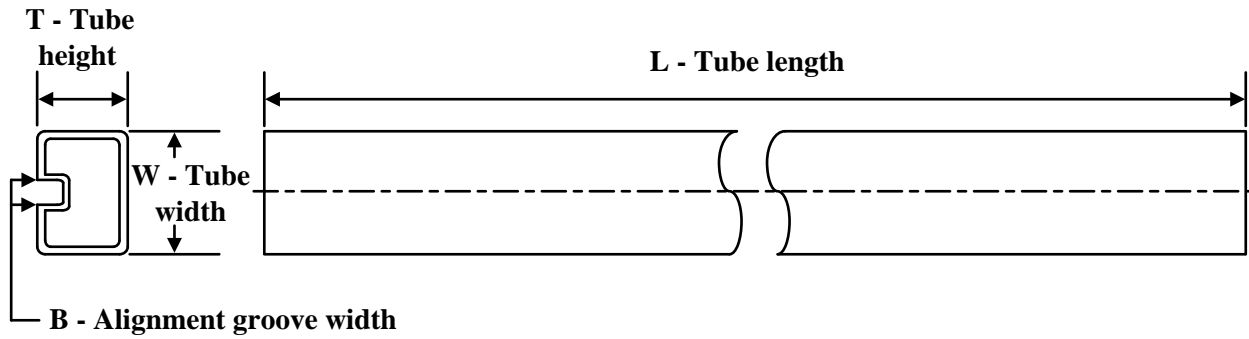
Device	Package Type	Package Drawing	Pins	SPQ	Length (mm)	Width (mm)	Height (mm)
SN74AHC595BQBR	WQFN	BQB	16	3000	210.0	185.0	35.0
SN74AHC595DBR	SSOP	DB	16	2000	356.0	356.0	35.0
SN74AHC595DR	SOIC	D	16	2500	340.5	336.1	32.0
SN74AHC595PWR	TSSOP	PW	16	2000	356.0	356.0	35.0
SN74AHC595PW RG4	TSSOP	PW	16	2000	367.0	367.0	35.0

**TUBE**

\*All dimensions are nominal

Device	Package Name	Package Type	Pins	SPQ	L (mm)	W (mm)	T (μm)	B (mm)
SN74AHC595N	N	PDIP	16	25	506	13.97	11230	4.32
SN74AHC595N	N	PDIP	16	25	506	13.97	11230	4.32

D (R-PDSO-G16)

PLASTIC SMALL OUTLINE



- NOTES:
- A. All linear dimensions are in inches (millimeters).
  - B. This drawing is subject to change without notice.
  - C. Body length does not include mold flash, protrusions, or gate burrs. Mold flash, protrusions, or gate burrs shall not exceed 0.006 (0,15) each side.
  - D. Body width does not include interlead flash. Interlead flash shall not exceed 0.017 (0,43) each side.
  - E. Reference JEDEC MS-012 variation AC.



4220204/A 02/2017

**NOTES:**

1. All linear dimensions are in millimeters. Any dimensions in parenthesis are for reference only. Dimensioning and tolerancing per ASME Y14.5M.
2. This drawing is subject to change without notice.
3. This dimension does not include mold flash, protrusions, or gate burrs. Mold flash, protrusions, or gate burrs shall not exceed 0.15 mm per side.
4. This dimension does not include interlead flash. Interlead flash shall not exceed 0.25 mm per side.
5. Reference JEDEC registration MO-153.

# EXAMPLE BOARD LAYOUT

PW0016A

TSSOP - 1.2 mm max height

SMALL OUTLINE PACKAGE



LAND PATTERN EXAMPLE  
EXPOSED METAL SHOWN  
SCALE: 10X



4220204/A 02/2017

NOTES: (continued)

- 6. Publication IPC-7351 may have alternate designs.
- 7. Solder mask tolerances between and around signal pads can vary based on board fabrication site.

# EXAMPLE STENCIL DESIGN

PW0016A

TSSOP - 1.2 mm max height

SMALL OUTLINE PACKAGE



SOLDER PASTE EXAMPLE  
BASED ON 0.125 mm THICK STENCIL  
SCALE: 10X

4220204/A 02/2017

NOTES: (continued)

8. Laser cutting apertures with trapezoidal walls and rounded corners may offer better paste release. IPC-7525 may have alternate design recommendations.
9. Board assembly site may have different recommendations for stencil design.

# DB0016A



# PACKAGE OUTLINE

## SSOP - 2 mm max height

SMALL OUTLINE PACKAGE

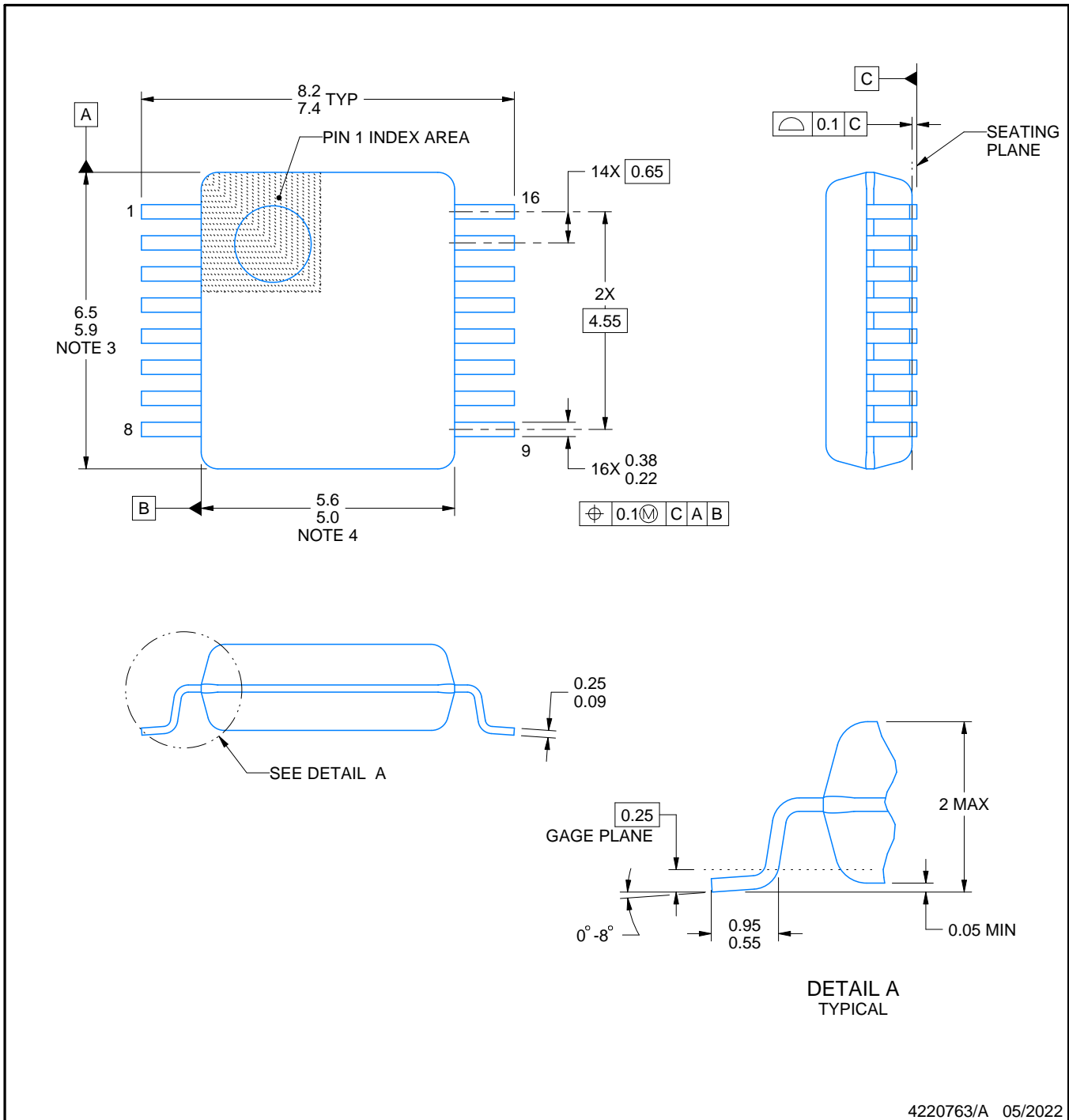

4220763/A 05/2022

### NOTES:

- All linear dimensions are in millimeters. Any dimensions in parenthesis are for reference only. Dimensioning and tolerancing per ASME Y14.5M.
- This drawing is subject to change without notice.
- This dimension does not include mold flash, protrusions, or gate burrs. Mold flash, protrusions, or gate burrs shall not exceed 0.15 mm per side.
- Reference JEDEC registration MO-150.

# EXAMPLE BOARD LAYOUT

DB0016A

SSOP - 2 mm max height

SMALL OUTLINE PACKAGE

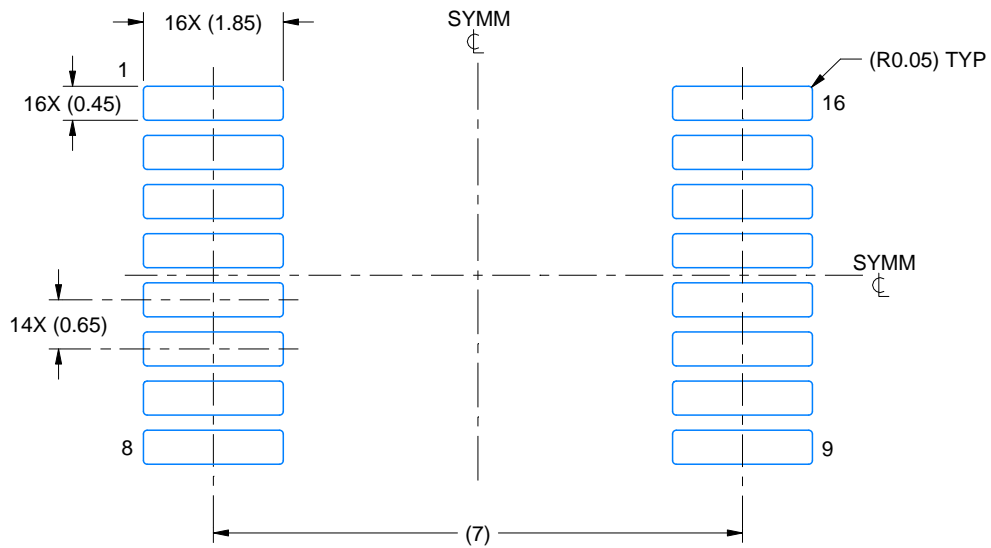

LAND PATTERN EXAMPLE  
EXPOSED METAL SHOWN  
SCALE: 10X

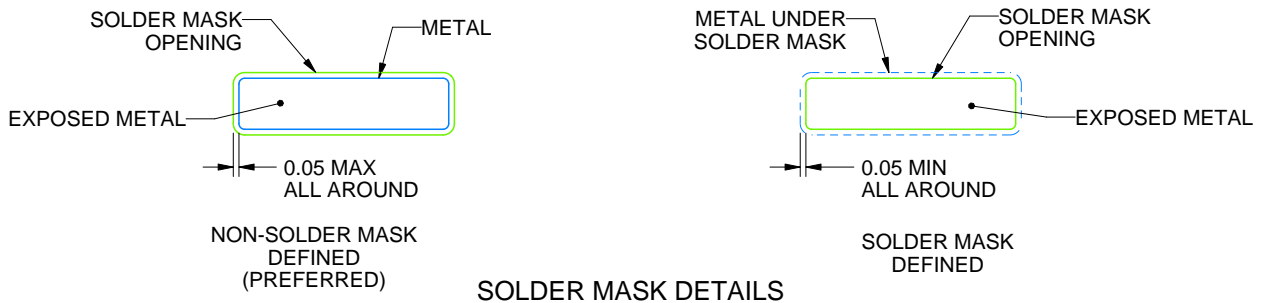

4220763/A 05/2022

NOTES: (continued)

- 5. Publication IPC-7351 may have alternate designs.
- 6. Solder mask tolerances between and around signal pads can vary based on board fabrication site.

# EXAMPLE STENCIL DESIGN

DB0016A

SSOP - 2 mm max height

SMALL OUTLINE PACKAGE

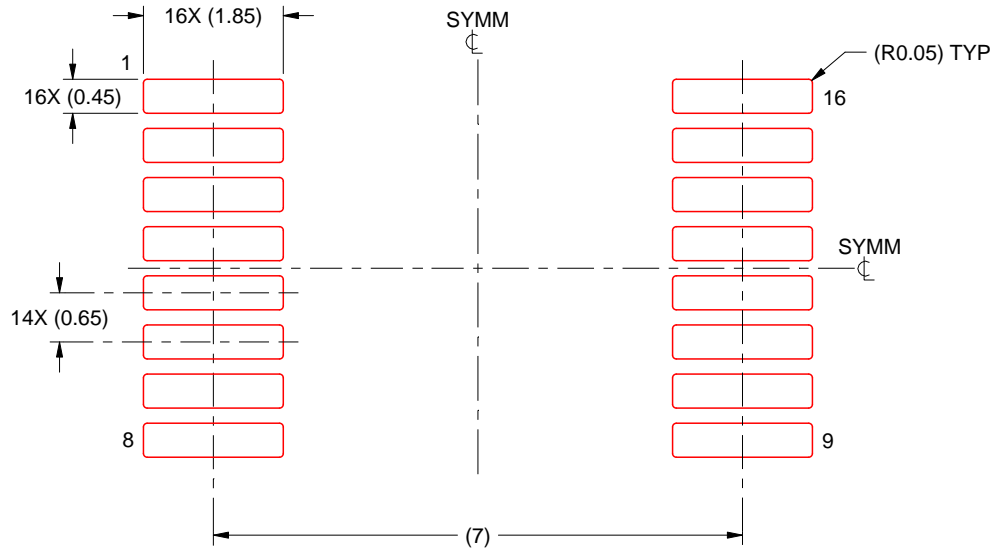

SOLDER PASTE EXAMPLE  
BASED ON 0.125 mm THICK STENCIL  
SCALE: 10X

4220763/A 05/2022

NOTES: (continued)

7. Laser cutting apertures with trapezoidal walls and rounded corners may offer better paste release. IPC-7525 may have alternate design recommendations.
8. Board assembly site may have different recommendations for stencil design.

## GENERIC PACKAGE VIEW

**BQB 16**

**WQFN - 0.8 mm max height**

2.5 x 3.5, 0.5 mm pitch

PLASTIC QUAD FLATPACK - NO LEAD

This image is a representation of the package family, actual package may vary.  
Refer to the product data sheet for package details.

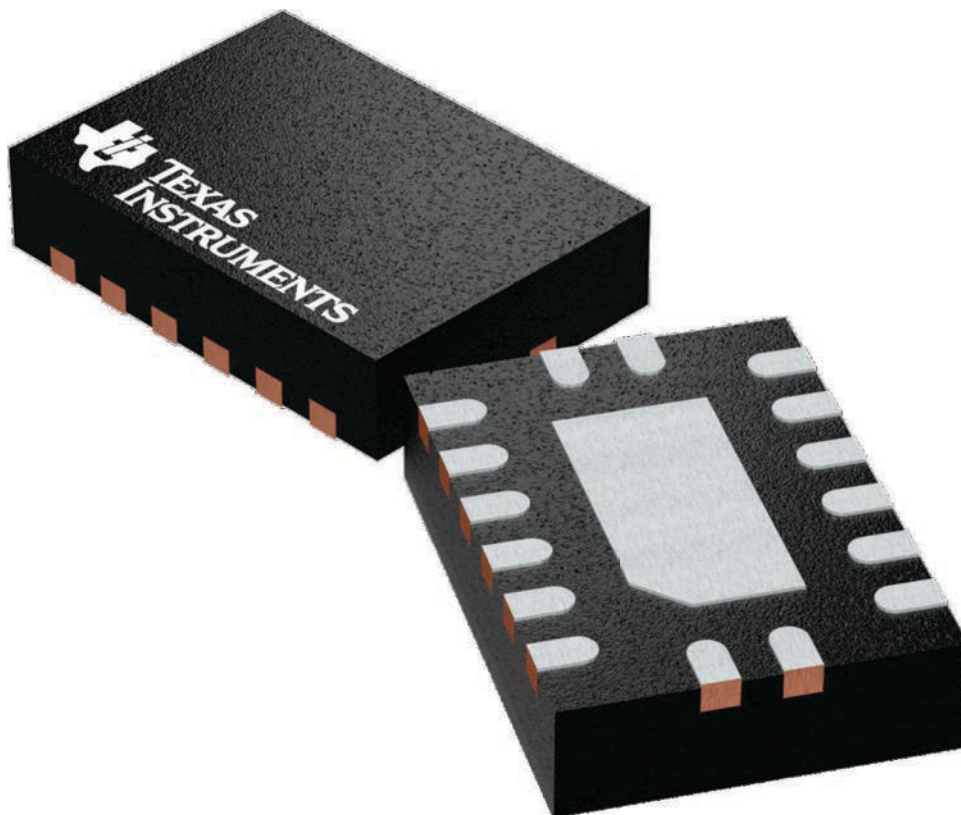

4226161/A

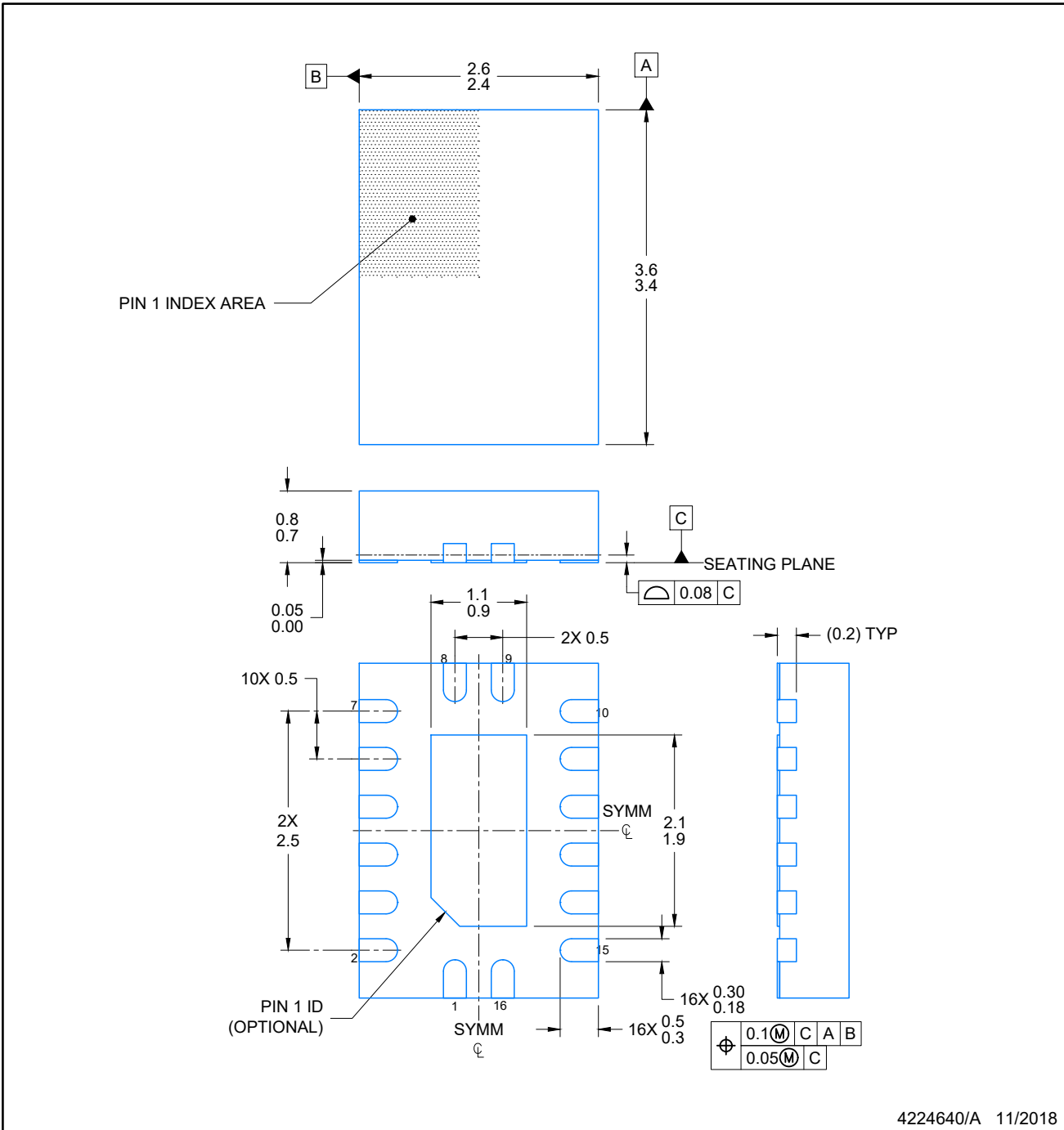

4224640/A 11/2018

**NOTES:**

1. All linear dimensions are in millimeters. Any dimensions in parenthesis are for reference only. Dimensioning and tolerancing per ASME Y14.5M.
2. This drawing is subject to change without notice.
3. The package thermal pad must be soldered to the printed circuit board for optimal thermal and mechanical performance.



**EXAMPLE STENCIL DESIGN**

**BQB0016A**

**WQFN - 0.8 mm max height**

PLASTIC QUAD FLAT PACK-NO LEAD

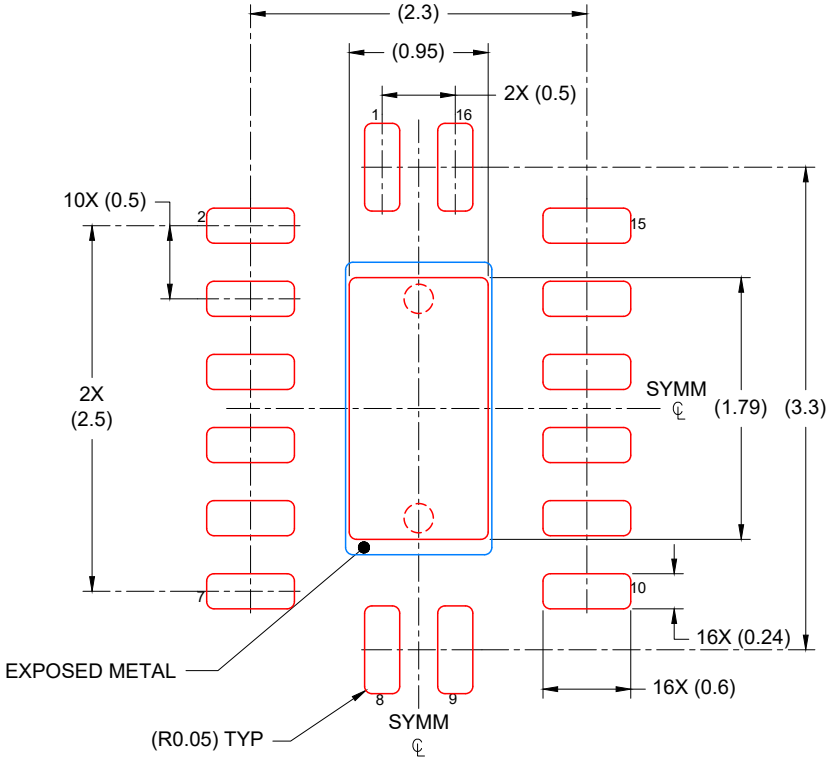

**SOLDER PASTE EXAMPLE**  
 BASED ON 0.125 mm THICK STENCIL

EXPOSED PAD  
 85% PRINTED COVERAGE BY AREA  
 SCALE: 20X

4224640/A 11/2018

NOTES: (continued)

- 6. Laser cutting apertures with trapezoidal walls and rounded corners may offer better paste release. IPC-7525 may have alternate design recommendations.

N (R-PDIP-T\*\*)

PLASTIC DUAL-IN-LINE PACKAGE

16 PINS SHOWN

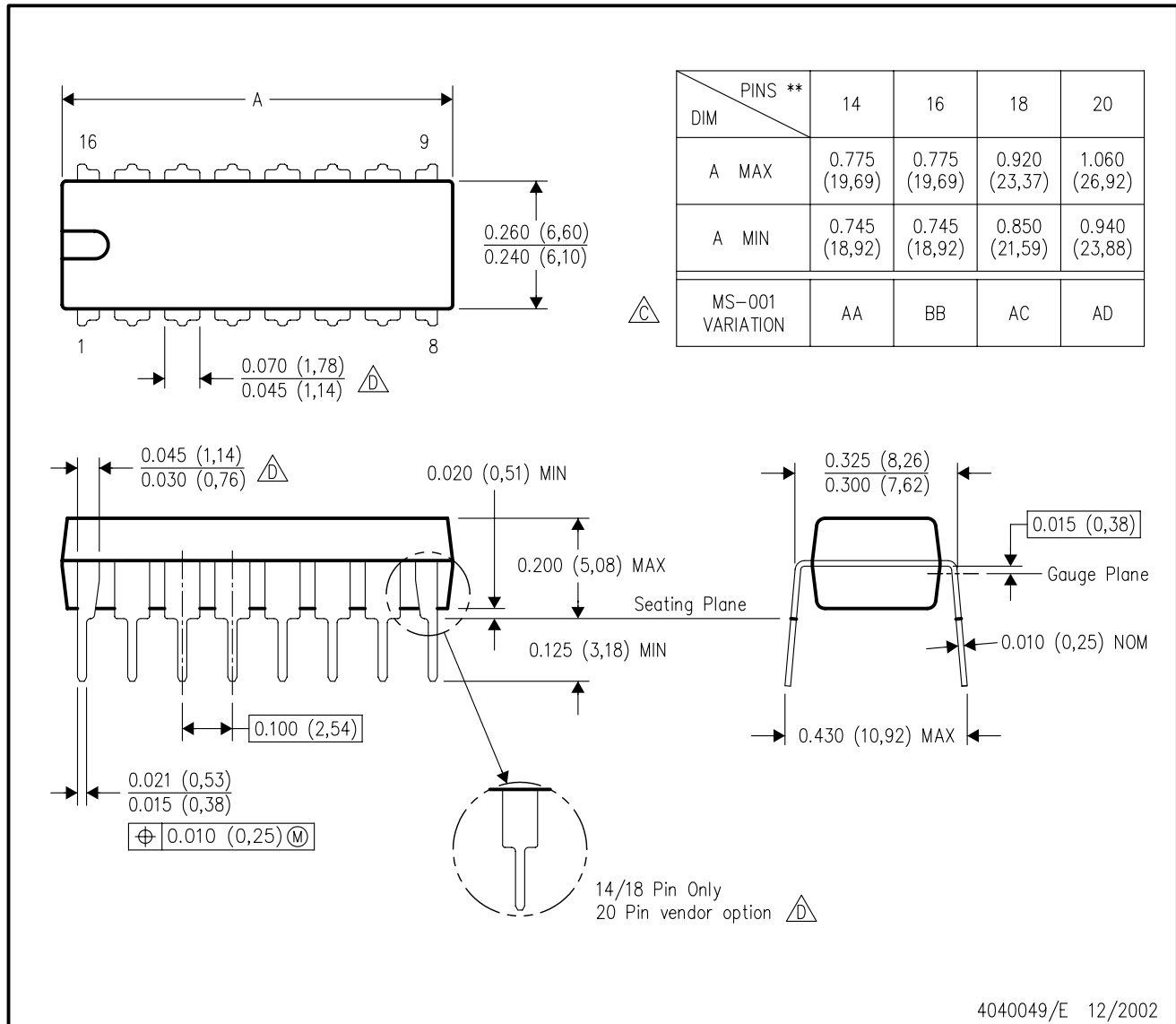

- NOTES:
- A. All linear dimensions are in inches (millimeters).
  - B. This drawing is subject to change without notice.
  - (C) Falls within JEDEC MS-001, except 18 and 20 pin minimum body length (Dim A).
  - (D) The 20 pin end lead shoulder width is a vendor option, either half or full width.

## 重要声明和免责声明

TI“按原样”提供技术和可靠性数据（包括数据表）、设计资源（包括参考设计）、应用或其他设计建议、网络工具、安全信息和其他资源，不保证没有瑕疵且不做任何明示或暗示的担保，包括但不限于对适销性、某特定用途方面的适用性或不侵犯任何第三方知识产权的暗示担保。

这些资源可供使用 TI 产品进行设计的熟练开发人员使用。您将自行承担以下全部责任：(1) 针对您的应用选择合适的 TI 产品，(2) 设计、验证并测试您的应用，(3) 确保您的应用满足相应标准以及任何其他功能安全、信息安全、监管或其他要求。

这些资源如有变更，恕不另行通知。TI 授权您仅可将这些资源用于研发本资源所述的 TI 产品的应用。严禁对这些资源进行其他复制或展示。您无权使用任何其他 TI 知识产权或任何第三方知识产权。您应全额赔偿因在这些资源的使用中对 TI 及其代表造成的任何索赔、损害、成本、损失和债务，TI 对此概不负责。

TI 提供的产品受 [TI 的销售条款](#) 或 [ti.com](#) 上其他适用条款/TI 产品随附的其他适用条款的约束。TI 提供这些资源并不会扩展或以其他方式更改 TI 针对 TI 产品发布的适用的担保或担保免责声明。

TI 反对并拒绝您可能提出的任何其他或不同的条款。

邮寄地址：Texas Instruments, Post Office Box 655303, Dallas, Texas 75265  
Copyright © 2024，德州仪器 (TI) 公司