

## Features

- Low Cost Miniature Plastic Package
- 6.6 dB Typical Conversion Loss at 1900 MHz
- 6.7 dB Typical Conversion Loss at 2200 MHz
- +13 to +17 dBm LO Drive
- HMIC™ Process
- Silicon High Barrier Schottky Diodes
- DC - 500 MHz IF Bandwidth
- RoHS\* Compliant with 260 °C. Reflow Capability
- 100% MATTE Tin Plating

## Description and Applications

M/A-COM's MA4EX190H1-1225T is a silicon monolithic 1700-2300 MHz double balanced mixer in a low cost miniature surface mount SOT-25 package. The die uses M/A-COM's unique HMIC™ silicon/glass process to achieve low loss passive elements while retaining the advantages of low barrier silicon Schottky diodes.

These mixers are well suited for high volume wireless and cellular applications where small size and repeatability are required. Typical applications include frequency conversion, modulation, and demodulation for receivers and transmitters in both portable cellular and base station applications.

## Ordering Information

Standard Part Number	Package
MA4EX190H1-1225T	Tape and Reel

## Absolute Maximum Ratings<sup>1</sup>

Parameter	Maximum Ratings
Operating Temperature	-40°C to +85°C
Storage Temperature	-65°C to 150°C
Incident LO Power	+20 dBm
Incident RF Power	+20 dBm
Solder Temperature	+260°C

1. Exceeding these limits may cause permanent damage.

\*Restrictions on Hazardous Substances, European Union Directive 2002/95/EC.

## SOT-25 Package Outline (Topview)

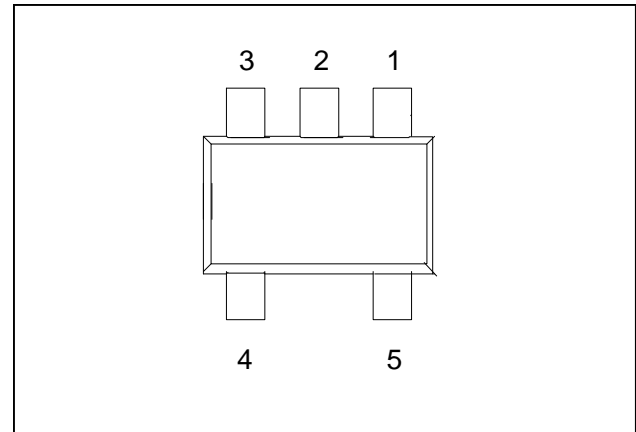

## PIN Configuration

PIN	Function	PIN	Function
1	RF	4	GND
2	GND	5	IF
3	LO		

## Schematic

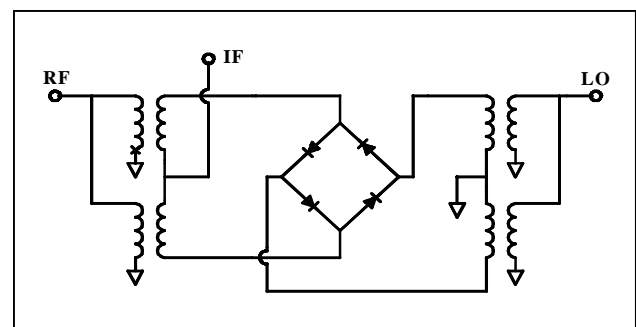

# MA4EX190H1-1225T



Silicon Double Balanced HMIC Mixer  
1700 - 2300 MHz

Rev. V2

## Electrical Specifications @ +25 °C

Parameter	Frequency Range	Test Conditions	Units	Min.	Typ.	Max.
Conversion Loss	1900 MHz 1700-2300 MHz	LO Drive = +15 dBm RF = -10 dBm, IF = 60 MHz	dB dB		6.6 6.7	7.0 8.0
L - R Isolation	1900 MHz 1700-2300 MHz	LO Drive = +15 dBm RF Level = -10 dBm	dB dB		30.0 30.0	
L - I Isolation	1900 MHz 1700-2300 MHz	LO Drive = +15 dBm RF Level = -10 dBm	dB dB		28.0 28.0	
R - I Isolation	1900 MHz 1700-2300 MHz	LO Drive = +15 dBm RF Level = -10 dBm	dB dB		23.0 20.0	
RF VSWR	1900 MHz 1700-2300 MHz	LO Drive = +15 dBm RF Level = -10 dBm			1.10:1 1.20:1	
IF VSWR	DC - 500 MHz	LO Drive = +15 dBm RF Level = -10 dBm			1.40:1	-
Input IP3	1900 MHz 1850-2300 MHz	LO Drive = +15 dBm IF = 60 MHz	dBm dBm	23 23	26.0 26.0	
Input 1 dB Compression	1900 MHz 1700-2300 MHz	LO Drive = +17 dBm IF = 60 MHz	dBm dBm		10.5 10.5	- -
IF 1 dB Bandwidth			MHz	0	500	-

## Typical Performance Curves (LO Drive = +15 dBm, RF = -10 dBm, IF = 60 MHz)

### Conversion Loss

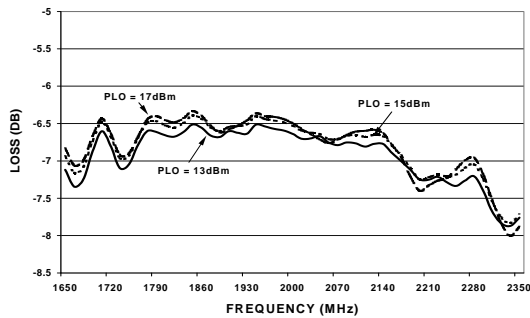

### Isolation

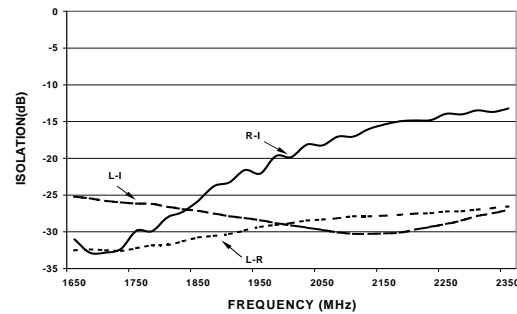

### VSWR

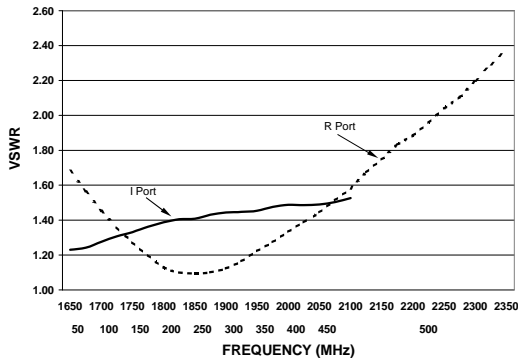

### Input IP3 & 1dB Compression Point

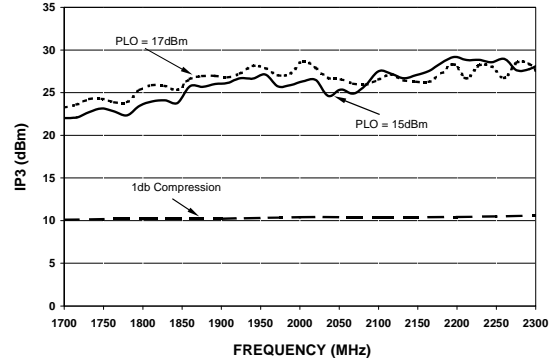

2

**ADVANCED:** Data Sheets contain information regarding a product M/A-COM Technology Solutions is considering for development. Performance is based on target specifications, simulated results, and/or prototype measurements. Commitment to develop is not guaranteed.  
**PRELIMINARY:** Data Sheets contain information regarding a product M/A-COM Technology Solutions has under development. Performance is based on engineering tests. Specifications are typical. Mechanical outline has been fixed. Engineering samples and/or test data may be available. Commitment to produce in volume is not guaranteed.

- **North America** Tel: 800.366.2266 / Fax: 978.366.2266
- **Europe** Tel: 44.1908.574.200 / Fax: 44.1908.574.300
- **Asia/Pacific** Tel: 81.44.844.8296 / Fax: 81.44.844.8298

Visit [www.macomtech.com](http://www.macomtech.com) for additional data sheets and product information.

M/A-COM Technology Solutions Inc. and its affiliates reserve the right to make changes to the product(s) or information contained herein without notice.

# MA4EX190H1-1225T



Silicon Double Balanced HMIC Mixer  
1700 - 2300 MHz

Rev. V2

## Case Style - SOT-25

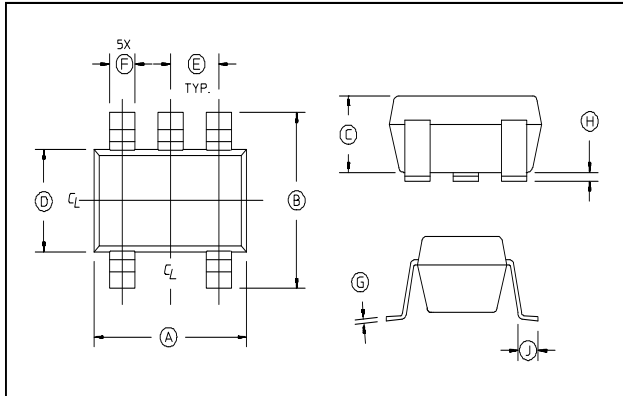

## SOT-25 Dimensions

Dim	Inches		Millimeters	
	Min.	Max.	Min.	Max.
A	.106	.122	2.70	3.10
B	.100	.118	2.54	3.00
C	—	.051	—	1.30
D	.063 REF.		1.60 REF.	
E	.032	.043	.80	1.10
F	.014	.020	.35	.50
G	.003	—	.08	—
H	.000	.006	.00	.15
J	.018 REF.		.45 REF.	

2. Leads Coplanarity should be 0.003 (0.08) max.