

修订 REV	标记 MARK	修改摘要 REVISION DESCRIPTION	签名 SIGNATURE	日期 DATE
A0		NEW DWG		2020-08-04

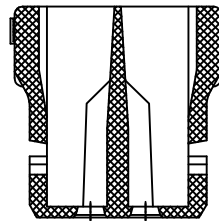

SEC:A-A

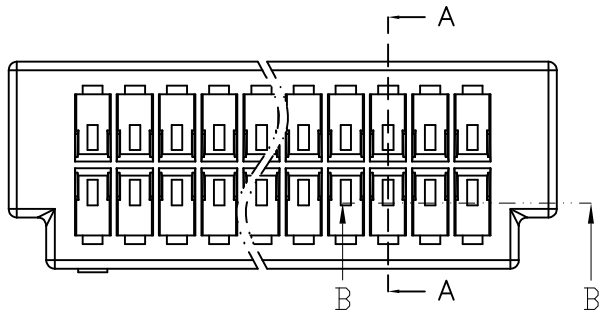
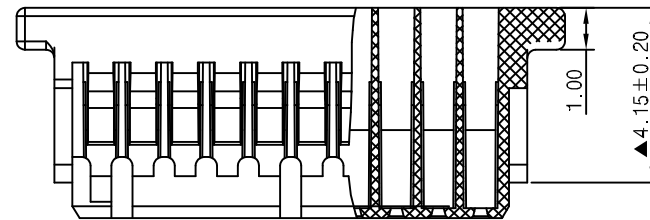
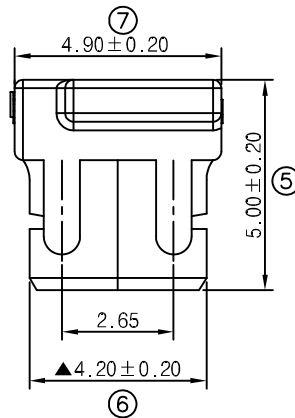
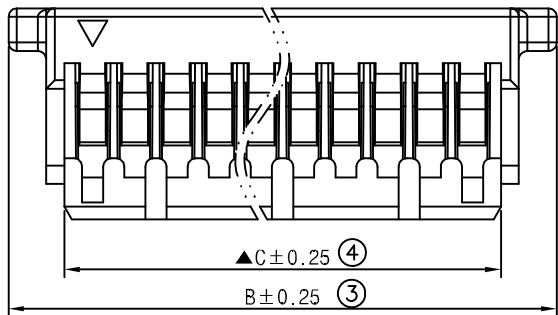
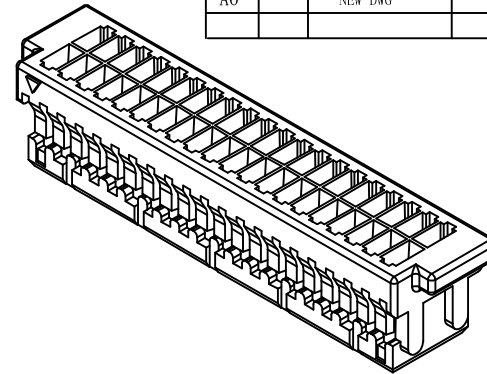

SEC:B-B

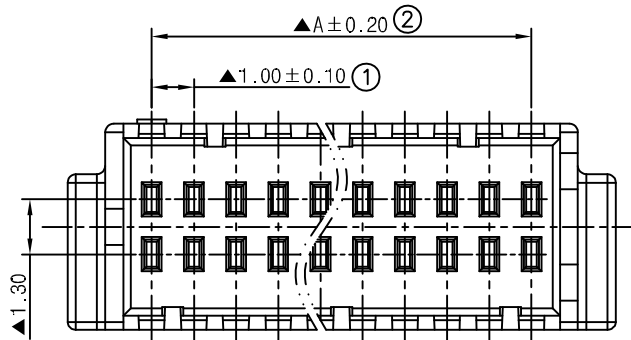

Circuit No.	Dimensions		
	A	B	C
2X04P	3.00	7.00	4.35
2X05P	4.00	8.00	5.35
2X06P	5.00	9.00	6.35
2X07P	6.00	10.00	7.35
2X08P	7.00	11.00	8.35
2X09P	8.00	12.00	9.35
2X10P	9.00	13.00	10.35
2X11P	10.00	14.00	11.35
2X15P	14.00	18.00	15.35
2X20P	19.00	23.00	20.35
2X25P	24.00	28.00	25.35

产品要求:

- 1、材质: PA66 UL 94V-0。
- 2、外观: 外形无缺胶、变形等不良。
- 3、尺寸: 全尺寸符合检测标准, ▲为重点尺寸。



深圳市华德共创科技有限公司

Shenzhen Huade co-create Technology Co., LTD

电话: 0755-27129737 传真: 0755-29940187

-TOLERANCES- UNLESS OTHERWISE SPECIFIED 公差参数表		TITLE: 产品名称: SH1.0H-2XNP	
X.X ± 0.30	X.X' ± 3'	APPD: 核准: 谢亮	PART NO: 产品编号: HDGC1002H-2xXP
X.XX ± 0.30	X.XX' ± 2'	CHECK: 校对: 王建业	DATE
X.XXX ± 0.10	X.XXX' ± 1'	DRAW: 绘图: 黄艳兰	SCALE
			UNIT
			CODE NUMBER
		2020-08-04	A001

修订 REV	标记 MARK	修改摘要 REVISION DESCRIPTION	签名 SIGNATURE	日期 DATE
A0		NEW DWG		2018-02-10
A1	※	端子头部增加斜面，使端子插入 塑胶更顺畅。		2020-12-22

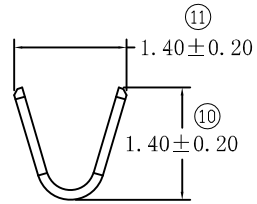
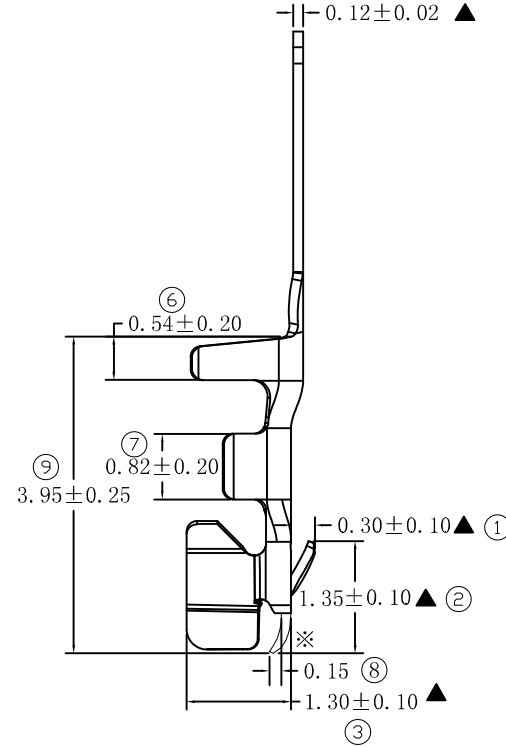
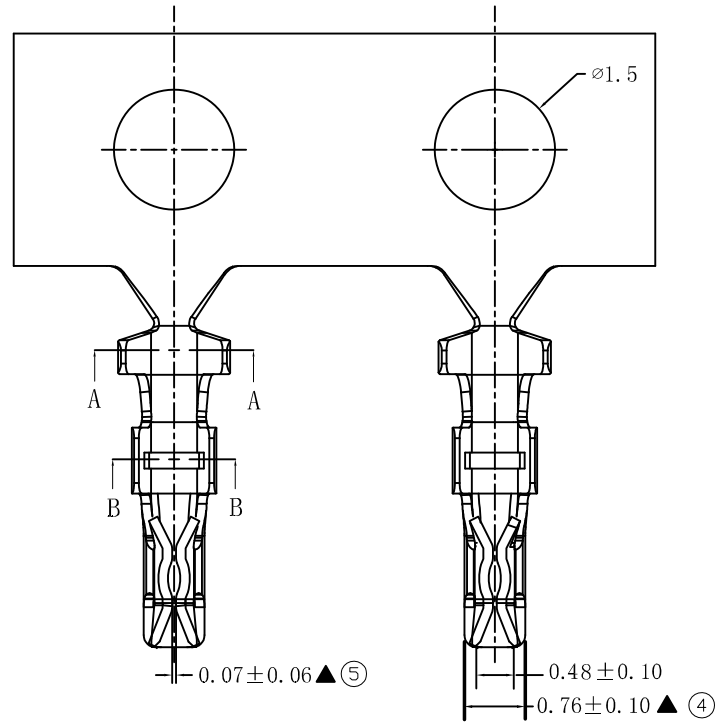

SECTION A-A

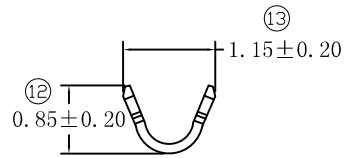

SECTION B-B

产品要求

1. 材质要求：磷铜，C5191；材厚：T=0.12±0.02
2. 电镀要求：先冲后镀 镀全锡 Ni底



深圳市华德共创科技有限公司

Shenzhen Huade co-create Technology Co., LTD

电话：0755-27129737 传真：0755-29940187

-TOLERANCES- UNLESS OTHERWISE SPECIFIED 公差参数表						TITLE: 产品名称: SH1.0-T			
X.X	±0.30	X.X°	±3°	APPD: 核准:	谢亮	PART NO: 产品编号: HDGC1002-T			
X.XX	±0.30	X.XX°	±2°	CHECK: 校对:	王建业	DATE	SCALE	UNIT	CODE NUMBER
X.XXX	±0.10	X.XXX°	±1°	DRAW: 绘图:	黄艳兰	2020-12-22	1:1	mm	A001