

PT3320 Series

**30 WATT ISOLATED
DC/DC CONVERTER**

[Application Notes](#)
[Mechanical Outline](#)
[Product Selector Guide](#)

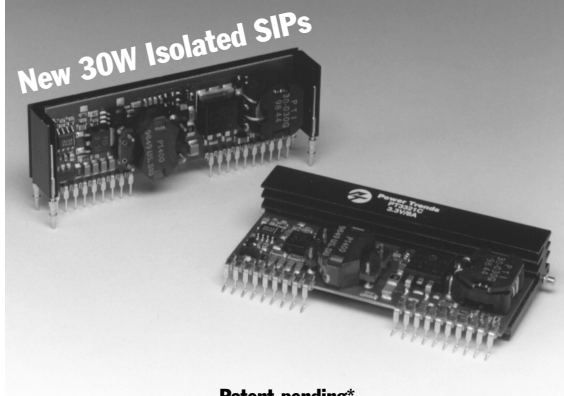

Patent pending*

The PT3320 is a new series of high-input voltage, 30 Watt, isolated DC to DC converters housed in a unique vertical or horizontal 19-pin SIP package. The 36 to 75V input range allows easy integration into many distributed power applications which utilize 48V bus architectures.

The PT3320 series is available with output voltages from 2V to 15V. The output voltage is adjustable from 90 to

110% of nominal with the addition of an external resistor. Other easy to use features include an inhibit function and differential remote sense which automatically compensates for any voltage drop from the converter to the load. The PT3320 includes built in current limit, short circuit protection and over-temperature shutdown.

The PT3320 requires a 330µF output capacitor for proper operation.

Standard Application

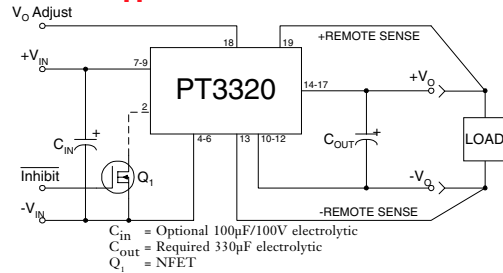

Pin-Out Information

Pin	Function	Pin	Function
1	Do Not Use	10	-V _o
2	Inhibit	11	-V _o
3	Do Not Use	12	-V _o
4	-V _{in}	13	-Remote Sense
5	-V _{in}	14	+V _o
6	-V _{in}	15	+V _o
7	+V _{in}	16	+V _o
8	+V _{in}	17	+V _o
9	+V _{in}	18	V _o Adjust
		19	+Remote Sense

Features

- 30W Output Power
- Input Voltage Range: 36V to 75V
- 1500 VDC Isolation
- V_o Inhibit
- V_o Adjust
- Differential Remote Sense
- Current Limit
- Short-Circuit Protection
- Over-Temperature Shutdown
- Undervoltage Lockout
- Flexible SIP Package
- UL 1950, CSA 22.2 950 approval pending
- Meets EN60950

Preliminary Specifications

Characteristics (T _a = 25°C unless noted)	Symbols	Conditions	PT3320 SERIES			
			Min	Typ	Max	Units
Output Current	I _o	Over V _{in} range	V _o = 3.3V 0.25 V _o = 5V 0.25 V _o = 12V 0.1	—	8.0 6.0 2.5	A
On/Off Standby Current	I _{in standby}	V _{in} = 48V, Pin 1 = -V _{in}	—	8	16	mA
Short Circuit Current	I _{sc}	V _{in} = 48V	—	2xI _{o max}	—	A
Input Voltage Range	V _{in}	Over I _o Range	36.0	48.0	75.0	V
Output Voltage Tolerance	ΔV _o	Over V _{in} Range T _A = -40°C to +85°C	—	±1.0	—	%V _o
Line Regulation	Reg _{line}	Over V _{in} range @ max I _o	—	±0.5	—	%V _o
Load Regulation	Reg _{load}	10% to 100% of I _o max	—	±0.5	—	%V _o
V _o Ripple/Noise	V _n	V _{in} =48V, I _o =I _o max, V _o ≥5V V _{in} =48V, I _o =I _o max, V _o <5V	—	1.0 50	—	%V _o mV _{pp}
Transient Response	t _{tr}	50% load change, 1A/µSec V _o over/undershoot, V _o ≥5V	—	100 3.0	—	µSec %V _o
Efficiency	η	V _{in} =48V, I _o =6A, V _o =3.3V V _{in} =48V, I _o =6A, V _o =5V V _{in} =48V, I _o =2.5A, V _o =12V	—	80 84 85	—	% % %
Switching Frequency	f _o	Over V _{in} and I _o	V _o <10V 400 V _o ≥10V	750 500	900 600	kHz kHz
Recommended Operating Temperature Range	T _a	V _{in} = 48V @ max I _o Airflow = 200 LFM	-40*	—	+85	°C
Storage Temperature	T _s	—	-40	—	+125	°C
Mechanical Shock	—	Per Mil-Std-883D, method 2002.3, 1mS, half-sine, mounted to a fixture	—	500	—	G's
Mechanical Vibration	—	Per Mil-Std-883D, method 2007.2, 20-2000Hz, soldered in a PC board	—	10	—	G's
Weight	—	—	—	40	—	grams
Input/Output Isolation Capacitance	—	—	1500	—	—	VDC pF
Resistance	—	—	10	—	—	MΩ
Flammability	—	Materials meet UL 94V-0	—	—	—	—
Inhibit (pin 2)	On** Off	Referenced to -V _{in}	2.5 0	—	15 0.8	VDC VDC

* At temperatures below 0°C, the PT3320 series requires output capacitors with temperature stable dielectrics such as tantalum or Oscon.

** If pin 2 is left open, the PT3320 will operate when input power is applied.

Ordering Information

- PT3321□ = 3.3V/8A
PT3322□ = 5.0V/6A
PT3323□ = 12.0V/2.5A
PT3324□ = 15.0V/2A
PT3325□ = 2.0V/8A
PT3326□ = 2.5V/8A
PT3327□ = 1.8V/8A
PT3328□ = 5.2V/6A

PT Series Suffix (PT1234X)

Case/Pin Configuration

Vertical Through-Hole	N
Horizontal Through-Hole	A
Horizontal Surface Mount	C

(For dimensions and PC board layout, see Package Styles 840 and 850.)

* **Note:** This product is the subject of one or more patents. Other patents pending.

PT3320 Series

CHARACTERISTIC DATA

PT3321, 3.3 VDC (See Note 1)

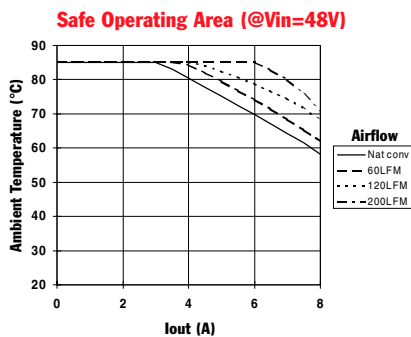
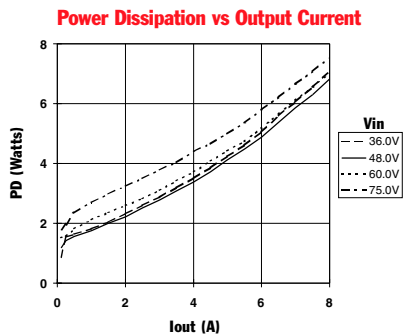
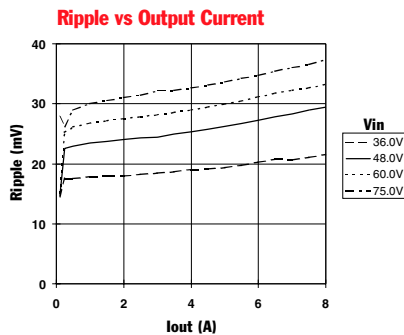
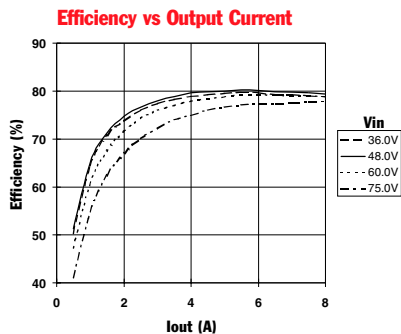

PT3322, 5.0 VDC (See Note 1)

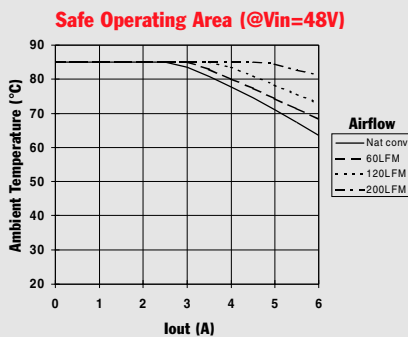
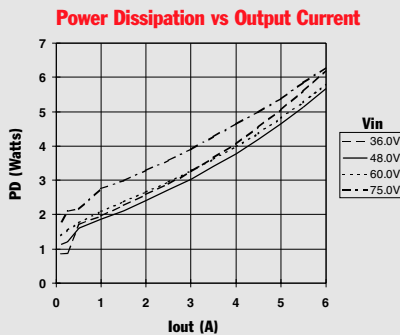
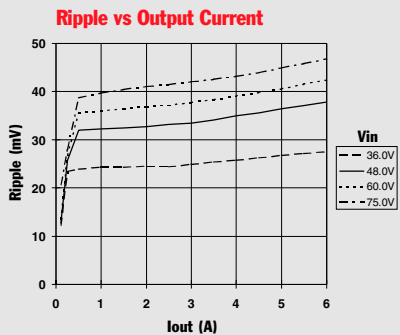
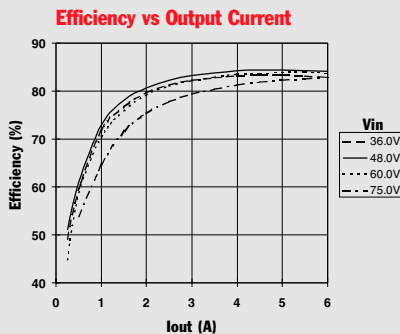

PT3323, 12.0 VDC (See Note 1)

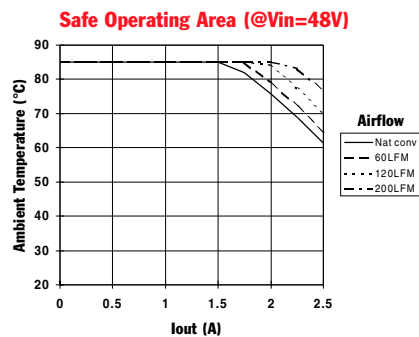
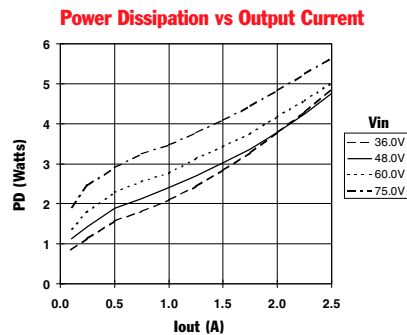
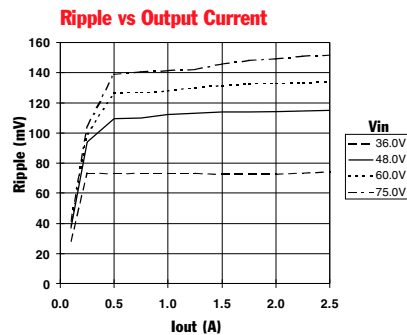
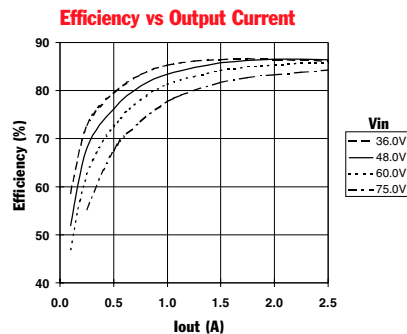

Note 1: All data listed in the above graphs has been developed from actual products tested at 25°C. This data is considered typical data for the DC-DC Converter.

[More Application Notes](#)**Adjusting the Output Voltage of the PT3320 / PT3340 Series of Isolated DC-DC Converters**

The factory pre-set output voltage of Power Trends' PT3320 and PT3340 series DC-DC converters may be adjusted within a nominal $\pm 10\%$ range. This is accomplished with the addition of a single external resistor. For the input voltage range specified in the data sheet, Table 1 gives the allowable adjustment range for each model as V_o (min) and V_o (max).

Adjust Up: An increase in the output voltage is obtained by adding a resistor, R2 between pin 18 (V_o adjust), and pin 13 (-Remote Sense). See note 4.

Adjust Down: Add a resistor (R1), between pin 18 (V_o adjust) and pin 19 (+Remote Sense).

Refer to Figure 1 and Table 2 for both the placement and value of the required resistor, (R1) or R2.

Notes:

- Use only a single 1% resistor in either the (R1) or R2 location. Place the resistor as close to the ISR as possible.
- Never connect capacitors to V_o adjust. Any capacitance added to the V_o adjust control pin will affect the stability of the ISR.

- If the remote sense pins are not being used, the resistors (R1) and R2 can be connected to $+V_{out}$ or $-V_{out}$ respectively.
- The adjusted output voltage V_a effectively sets the voltage across pins 13 and 19 (\pm Remote Sense). When using the remote sense pins, V_{out} (measured directly across pins 10-12, and 14-17) can be significantly higher than V_a , and may exceed V_o (max). If V_a is adjusted upward, the alternative is to increase the minimum input voltage by the same percentage as V_{out} exceeds V_o (max).

The values of (R1) [adjust down], and R2 [adjust up], can also be calculated using the following formulas.

$$(R1) = \frac{R_o (V_o - V_r)(V_a - V_r)}{V_r (V_o - V_a)} - R_s \quad k\Omega$$

$$R2 = \frac{R_o (V_o - V_r)}{(V_a - V_o)} - R_s \quad k\Omega$$

Where V_o = Original output voltage
 V_a = Adjusted output voltage
 V_r = Reference voltage (Table 1)
 R_o = Multiplier resistance (Table 1)
 R_s = Series resistance (Table 1)

Table 1**DC-DC CONVERTER ADJUSTMENT RANGE AND FORMULA PARAMETERS**

Series Pt #						
24V Bus			PT3341	PT3342	PT3343	PT3344
48V Bus	PT3325	PT3326	PT3321	PT3322	PT3323	PT3324
V_o (nom)	2.0V	2.5	3.3	5.0	12.0	15.0
V_o (min)	1.8V	2.25	2.95	4.5	10.8	13.5
V_o (max)	2.2	2.75	3.65	5.5	13.2	16.5
V_r	1.225	1.225	1.225	1.225	2.5	2.5
R_o (k Ω)	80.6	33.2	33.2	18.2	14.3	11.0
R_s (k Ω)	150.0	121.0	150.0	121.0	90.9	80.6

Figure 1

Table 2

PT3320 / PT3340 ADJUSTMENT RESISTOR VALUES

Series Pt #							
24V Bus	PT3341		PT3342		PT3343	PT3344	
48V Bus	PT3325	PT3326	PT3321	PT3322	PT3323	PT3324	
Current	8Adc	8Adc	8Adc	6adc	2.5Adc	2.0Adc	
V _o (nom)	2.0Vdc	2.5Vdc	3.3Vdc	5.0Vdc	12.0Vdc	15.0Vdc	
V _a (req'd)				V _a (req'd)	V _a (req'd)		
1.8	0.0kΩ			4.5	(246.0)kΩ	10.8	(285.0)kΩ
1.85	(62.5)kΩ			4.55	(293.0)kΩ	11.0	(371.0)kΩ
1.9	(194.0)kΩ			4.6	(352.0)kΩ	11.2	(500.0)kΩ
1.95	(589.0)kΩ			4.65	(428.0)kΩ	11.4	(715.0)kΩ
2.0				4.7	(529.0)kΩ	11.6	(1150.0)kΩ
2.05	1100.0kΩ			4.75	(670.0)kΩ	11.8	
2.1	475.0kΩ			4.8	(882.0)kΩ	12.0	
2.15	266.0kΩ			4.85	(1230.0)kΩ	12.2	588.0kΩ
2.2	162.0kΩ			4.9	(1940.0)kΩ	12.4	249.0kΩ
2.25		(20.7)kΩ		4.95		12.6	136.0kΩ
2.3		(64.7.0)kΩ		5.0		12.8	78.9kΩ
2.35		(138.0)kΩ		5.05		13.0	45.0kΩ
2.4		(285.0)kΩ		5.1	566.0kΩ	13.2	22.3kΩ
2.45		(726.0)kΩ		5.15	337.0kΩ		
2.5				5.2	223.0kΩ	13.5	(323.0)kΩ
2.55		726.0kΩ		5.25	154.0kΩ	13.6	(355.0)kΩ
2.6		302.0kΩ		5.3	108.0kΩ	13.8	(437.0)kΩ
2.65		161.0kΩ		5.35	75.3kΩ	14.0	(522.0)kΩ
2.7		90.6kΩ		5.4	50.8kΩ	14.2	(724.0)kΩ
2.75		48.3kΩ		5.45	31.7kΩ	14.4	(1010.0)kΩ
2.95			(127.0)kΩ	5.5	16.4kΩ	14.6	(1580.0)kΩ
3.0			(183.0)kΩ			14.8	
3.05			(261.0)kΩ			15.0	
3.1			(377.0)kΩ			15.2	607.0kΩ
3.15			(572.0)kΩ			15.4	263.0kΩ
3.2			(961.0)kΩ			15.6	149.0kΩ
3.25			(2130.0)kΩ			15.8	91.3kΩ
3.3						16.0	56.9kΩ
3.35			1230.0kΩ			16.5	11.1kΩ
3.4			539.0kΩ				
3.45			309.0kΩ				
3.5			194.0kΩ				
3.55			126.0kΩ				
3.6			79.6kΩ				
3.65			46.8kΩ				

R1 = (Red) R2 = Black

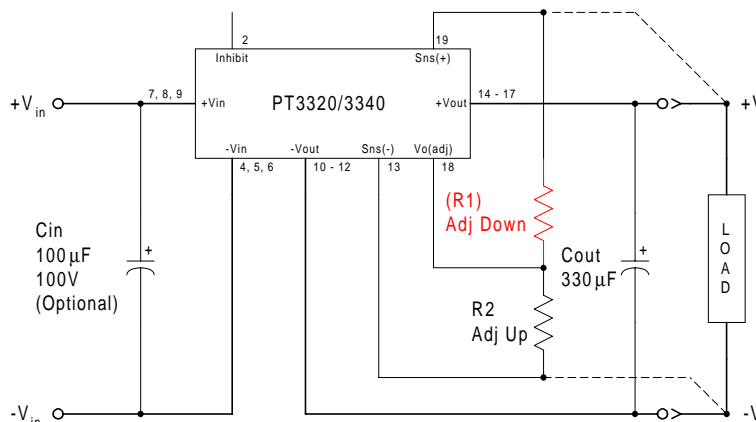
IMPORTANT NOTICE

Texas Instruments and its subsidiaries (TI) reserve the right to make changes to their products or to discontinue any product or service without notice, and advise customers to obtain the latest version of relevant information to verify, before placing orders, that information being relied on is current and complete. All products are sold subject to the terms and conditions of sale supplied at the time of order acknowledgement, including those pertaining to warranty, patent infringement, and limitation of liability.

TI warrants performance of its semiconductor products to the specifications applicable at the time of sale in accordance with TI's standard warranty. Testing and other quality control techniques are utilized to the extent TI deems necessary to support this warranty. Specific testing of all parameters of each device is not necessarily performed, except those mandated by government requirements.

CERTAIN APPLICATIONS USING SEMICONDUCTOR PRODUCTS MAY INVOLVE POTENTIAL RISKS OF DEATH, PERSONAL INJURY, OR SEVERE PROPERTY OR ENVIRONMENTAL DAMAGE ("CRITICAL APPLICATIONS"). TI SEMICONDUCTOR PRODUCTS ARE NOT DESIGNED, AUTHORIZED, OR WARRANTED TO BE SUITABLE FOR USE IN LIFE-SUPPORT DEVICES OR SYSTEMS OR OTHER CRITICAL APPLICATIONS. INCLUSION OF TI PRODUCTS IN SUCH APPLICATIONS IS UNDERSTOOD TO BE FULLY AT THE CUSTOMER'S RISK.

In order to minimize risks associated with the customer's applications, adequate design and operating safeguards must be provided by the customer to minimize inherent or procedural hazards.

TI assumes no liability for applications assistance or customer product design. TI does not warrant or represent that any license, either express or implied, is granted under any patent right, copyright, mask work right, or other intellectual property right of TI covering or relating to any combination, machine, or process in which such semiconductor products or services might be or are used. TI's publication of information regarding any third party's products or services does not constitute TI's approval, warranty or endorsement thereof.