

## General Description

The 813N2532 device uses IDT's fourth generation FemtoClock® NG technology for optimal high clock frequency and low phase noise performance, combined with a low power consumption and high power supply noise rejection. The 813N2532 is a PLL based synchronous multiplier that is optimized for PDH or SONET to Ethernet clock jitter attenuation and frequency translation.

The 813N2532 is a fully integrated Phase Locked loop utilizing a FemtoClock NG Digital VCXO that provides the low jitter, high frequency SONET/PDH output clock that easily meets OC-48 jitter requirements. This VCXO technology simplifies PLL design by replacing the pullable crystal requirement of analog VCXOs with a fixed 27MHz generator crystal. Jitter attenuation down to 10Hz is provided by an external loop filter. Pre-divider and output divider multiplication ratios are selected using device selection control pins. The multiplication ratios are optimized to support most common clock rates used in PDH, SONET and Ethernet applications. The device requires the use of an external, inexpensive fundamental mode 27MHz crystal. The device is packaged in a space-saving 32-VFQFN package and supports commercial temperature range.

## Pin Assignment

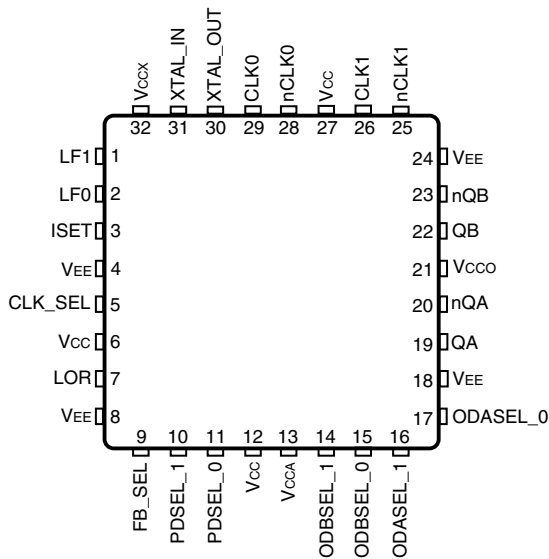

### 813N2532

**32 Lead VFQFN**

**5mm x 5mm x 0.925mm package body**

**3.15mm x 3.15mm ePad size**

**K Package**

**Top View**

## Features

- Fourth generation FemtoClock® NG technology
- Two LVPECL output pairs
- Output frequencies: 19.44MHz, 25MHz, 125MHz, 155.52MHz and 156.25MHz
- Two differential inputs support the following input types: LVPECL, LVDS, LVHSTL, HCSL
- Accepts input frequencies from 8kHz to 38.88MHz including 8kHz, 19.44MHz, 25MHz and 38.88MHz
- Crystal interface optimized for a 27MHz, 10pF parallel resonant crystal
- Attenuates the phase jitter of the input clock by using a low-cost fundamental mode crystal
- Customized settings for jitter attenuation and reference tracking using external loop filter connection
- FemtoClock NG frequency multiplier provides low jitter, high frequency output
- Absolute pull range:  $\pm 100$ ppm
- Power supply noise rejection (PSNR): -95dB (typical)
- RMS phase jitter @ 156.25MHz, using a 27MHz crystal (12kHz – 20MHz): 0.64ps (typical)
- RMS phase jitter @ 155.52MHz, using a 27MHz crystal (12kHz – 20MHz): 0.64ps (typical)
- RMS phase jitter @ 125MHz, using a 27MHz crystal (12kHz – 20MHz): 0.66ps (typical)
- 3.3V supply voltage
- 0°C to 70°C ambient operating temperature
- Lead-free (RoHS 6) packaging

# Block Diagram

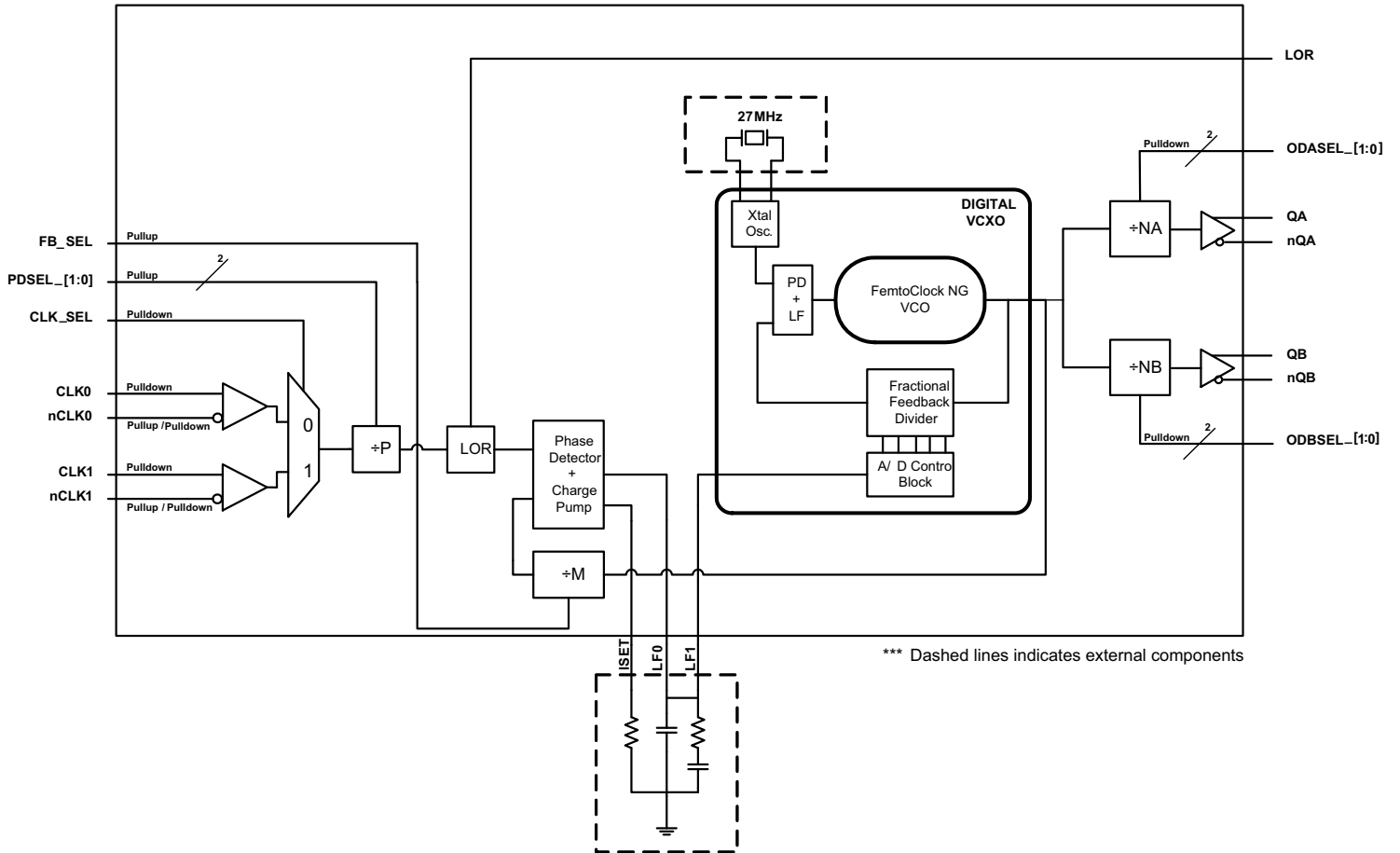

## Pin Description and Pin Characteristics Tables

**Table 1. Pin Descriptions**

Number	Name	Type		Description
1, 2	LF1, LF0	Analog Input/Output		Loop filter connection node pins. LF0 is the output. LF1 is the input.
3	ISET	Analog Input/Output		Charge pump current setting pin.
4, 8, 18, 24	V <sub>EE</sub>	Power		Negative supply pins.
5	CLK_SEL	Input	Pulldown	Input clock select. When HIGH selects CLK1, nCLK1. When LOW, selects CLK0, nCLK0. LVCMOS / LVTTTL interface levels.
6, 12, 27	V <sub>CC</sub>	Power		Core supply pins.
7	LOR	Output		Loss of reference indicator. LVCMOS/LVTTTL interface levels.
9	FB_SEL	Input	Pullup	Feedback divider select pin. LVCMOS/LVTTTL interface levels. See Table 3B.
10, 11	PDSEL_1, PDSEL_0	Input	Pullup	Pre-divider select pins. LVCMOS/LVTTTL interface levels. See Table 3A.
13	V <sub>CCA</sub>	Power		Analog supply pin.
14, 15	ODBSEL_1, ODBSEL_0	Input	Pulldown	Frequency select pins for Bank B output. See Table 3C. LVCMOS/LVTTTL interface levels.
16, 17	ODASEL_1, ODASEL_0	Input	Pulldown	Frequency select pins for Bank A output. See Table 3C. LVCMOS/LVTTTL interface levels.
19, 20	QA, nQA	Output		Differential Bank A clock outputs. LVPECL interface levels.
21	V <sub>CCO</sub>	Power		Output supply pin.
22, 23	QB, nQB	Output		Differential Bank B clock outputs. LVPECL interface levels.
25	nCLK1	Input	Pullup/ Pulldown	Inverting differential clock input. V <sub>CC</sub> /2 bias voltage when left floating.
26	CLK1	Input	Pulldown	Non-inverting differential clock input.
28	nCLK0	Input	Pullup/ Pulldown	Inverting differential clock input. V <sub>CC</sub> /2 bias voltage when left floating.
29	CLK0	Input	Pulldown	Non-inverting differential clock input.
30, 31	XTAL_OUT, XTAL_IN	Input		Crystal oscillator interface. XTAL_IN is the input. XTAL_OUT is the output.
32	V <sub>CCX</sub>	Power		Power supply pin for the crystal oscillator.

NOTE: *Pullup* and *Pulldown* refer to internal input resistors. See Table 2, *Pin Characteristics*, for typical values.

**Table 2. Pin Characteristics**

Symbol	Parameter	Test Conditions	Minimum	Typical	Maximum	Units
C <sub>IN</sub>	Input Capacitance			2		pF
R <sub>PULLUP</sub>	Input Pullup Resistor			51		kΩ
R <sub>PULLDOWN</sub>	Input Pulldown Resistor			51		kΩ

## Function Tables

**Table 3A. Pre-Divider Selection Function Table**

Inputs		÷P Value
PDSEL_1	PDSEL_0	
0	0	1
0	1	1944
1	0	2500
1	1	3888 (default)

**Table 3C. Output Divider Function Table**

Inputs		÷Nx Value
ODxSEL_1	ODxSEL_0	
0	0	128 (default)
0	1	100
1	0	20
1	1	16

NOTE: x denotes A or B.

**Table 3B. Feedback Divider Selection Function Table**

Input	VCO Frequency (MHz)
FB_SEL	
0	2500
1	2488.32 (default)

**Table 3D. Frequency Function Table**

Input Frequency (MHz)	÷P Value	FemtoClock NG VCXO Center Frequency (MHz)	÷Nx Value	Output Frequency (MHz)
0.008	1	2488.32	128	19.44
0.008	1	2500	100	25
0.008	1	2500	20	125
0.008	1	2488.32	16	155.52
0.008	1	2500	16	156.25
19.44	1944	2488.32	128	19.44
19.44	1944	2500	100	25
19.44	1944	2500	20	125
19.44	1944	2488.32	16	155.52
19.44	1944	2500	16	156.25
25	2500	2488.32	128	19.44
25	2500	2500	100	25
25	2500	2500	20	125
25	2500	2488.32	16	155.52
25	2500	2500	16	156.25
38.88	3888	2488.32	128	19.44
38.88	3888	2500	100	25
38.88	3888	2500	20	125
38.88	3888	2488.32	16	155.52
38.88	3888	2500	16	156.25

NOTE: x denotes A or B.

## Absolute Maximum Ratings

NOTE: Stresses beyond those listed under *Absolute Maximum Ratings* may cause permanent damage to the device. These ratings are stress specifications only. Functional operation of product at these conditions or any conditions beyond those listed in the *DC Characteristics* or *AC Characteristics* is not implied. Exposure to absolute maximum rating conditions for extended periods may affect product reliability.

Item	Rating
Supply Voltage, $V_{CC}$	3.63V
Inputs, $V_I$ XTAL_IN Other Inputs	0V to 2V -0.5V to $V_{CC} + 0.5V$
Outputs, $I_O$ Continuous Current Surge Current	50mA 100mA
Package Thermal Impedance, $\theta_{JA}$	33.1°C/W (0 mps)
Storage Temperature, $T_{STG}$	-65°C to 150°C

## DC Electrical Characteristics

**Table 4A. LVPECL Power Supply DC Characteristics,  $V_{CC} = V_{CCO} = V_{CCX} = 3.3V \pm 5\%$ ,  $V_{EE} = 0V$ ,  $T_A = 0^\circ C$  to  $70^\circ C$**

Symbol	Parameter	Test Conditions	Minimum	Typical	Maximum	Units
$V_{CC}$	Core Supply Voltage		3.135	3.3	3.465	V
$V_{CCA}$	Analog Supply Voltage		$V_{CC} - 0.29$	3.3	$V_{CC}$	V
$V_{CCO}$	Output Supply Voltage		3.135	3.3	3.465	V
$V_{CCX}$	Crystal Supply Voltage		3.135	3.3	3.465	V
$I_{EE}$	Power Supply Current				312	mA
$I_{CCA}$	Analog Supply Current				29	mA

**Table 4B. LVCMOS/LVTTL DC Characteristics,  $V_{CC} = V_{CCO} = V_{CCX} = 3.3V \pm 5\%$ ,  $T_A = 0^\circ C$  to  $70^\circ C$**

Symbol	Parameter	Test Conditions	Minimum	Typical	Maximum	Units
$V_{IH}$	Input High Voltage		2		$V_{CC} + 0.3$	V
$V_{IL}$	Input Low Voltage		-0.3		0.8	V
$I_{IH}$	Input High Current	CLK_SEL, CLK0, ODASEL_[1:0], ODBSEL_[1:0]	$V_{CC} = V_{IN} = 3.465V$		150	$\mu A$
		FB_SEL, PDSEL_[1:0]	$V_{CC} = V_{IN} = 3.465V$		10	$\mu A$
$I_{IL}$	Input Low Current	CLK_SEL, CLK0, ODASEL_[1:0], ODBSEL_[1:0]	$V_{CC} = 3.465V, V_{IN} = 0V$	-10		$\mu A$
		FB_SEL, PDSEL_[1:0]	$V_{CC} = 3.465, V_{IN} = 0V$	-150		$\mu A$

**Table 4C. Differential DC Characteristics,  $V_{CC} = V_{CC0} = V_{CCX} = 3.3V \pm 5\%$ ,  $T_A = 0^\circ C$  to  $70^\circ C$** 

Symbol	Parameter	Test Conditions	Minimum	Typical	Maximum	Units
$I_{IH}$	Input High Current	CLK0, nCLK0, CLK1, nCLK1 $V_{CC} = V_{IN} = 3.465V$			150	$\mu A$
$I_{IL}$	Input Low Current	CLK0, CLK1 $V_{CC} = 3.465V, V_{IN} = 0V$	-10			$\mu A$
		nCLK0, nCLK1 $V_{CC} = 3.465V, V_{IN} = 0V$	-150			$\mu A$
$V_{PP}$	Peak-to-Peak Input Voltage; NOTE 1		0.15		1.3	V
$V_{CMR}$	Common Mode Input Voltage; NOTES 1, 2		$V_{EE}$		$V_{CC} - 0.85$	V

 NOTE 1:  $V_{IL}$  should not be less than -0.3V.

NOTE 2. Common mode voltage is defined at the crosspoint.

**Table 4D. LVPECL DC Characteristics,  $V_{CC} = V_{CC0} = V_{CCX} = 3.3V \pm 5\%$ ,  $V_{EE} = 0V$ ,  $T_A = 0^\circ C$  to  $70^\circ C$** 

Symbol	Parameter	Test Conditions	Minimum	Typical	Maximum	Units
$V_{OH}$	Output High Voltage; NOTE 1		$V_{CC0} - 1.10$		$V_{CC0} - 0.75$	V
$V_{OL}$	Output Low Voltage; NOTE 1		$V_{CC0} - 2.0$		$V_{CC0} - 1.6$	V
$V_{SWING}$	Peak-to-Peak Output Voltage Swing		0.6		1.0	V

 NOTE 1: Outputs terminated with  $50\Omega$  to  $V_{CC0} - 2V$ . See Parameter Measurement Information section, *3.3V Output Load Test Circuit*.

## AC Electrical Characteristics

**Table 5. AC Characteristics,  $V_{CC} = V_{CCO} = V_{CCX} = 3.3V \pm 5\%$ ,  $T_A = 0^\circ C$  to  $70^\circ C$**

Symbol	Parameter	Test Conditions	Minimum	Typical	Maximum	Units
$f_{IN}$	Input Frequency		0.008		38.88	MHz
$f_{OUT}$	Output Frequency		19.44		156.25	MHz
$f_{jit}(\emptyset)$	RMS Phase Jitter, (Random), NOTE 1	156.25MHz $f_{OUT}$ , 27MHz crystal, Integration Range: 12kHz – 20MHz		0.64		ps
		155.52MHz $f_{OUT}$ , 27MHz crystal, Integration Range: 12kHz – 20MHz		0.64		ps
		125MHz $f_{OUT}$ , 27MHz crystal, Integration Range: 12kHz – 20MHz		0.66		ps
$t_{sk(o)}$	Output Skew; NOTE 2, 3				80	ps
PSNR	Power Supply Noise Rejection; NOTE 4	$V_{PP} = 50mV$ Sine Wave, Range: 10kHz – 10MHz		-95		dB
$t_R / t_F$	Output Rise/Fall Time	20% to 80%	200		500	ps
odc	Output Duty Cycle		48		52	%
$t_{LOCK}$	Output-to-Input Phase Lock Time; NOTE 5	Reference Clock Input is $\pm 100ppm$ from Nominal Frequency		3		s

NOTE: Electrical parameters are guaranteed over the specified ambient operating temperature range, which is established when the device is mounted in a test socket with maintained transverse airflow greater than 500 lfm. The device will meet specifications after thermal equilibrium has been reached under these conditions.

NOTE: Characterized with outputs at the same frequency using the loop filter components for the 44Hz loop bandwidth. Refer to Jitter Attenuator Loop Bandwidth Selection Table.

NOTE 1: Refer to the Phase Noise Plot.

NOTE 2: This parameter is defined in accordance with JEDEC Standard 65.

NOTE 3: Defined as skew between outputs at the same supply voltage and with equal load conditions. Measured at the output differential cross point.

NOTE 4: PSNR results achieved by injecting noise on  $V_{CCA}$  supply pin with no external filter network.

NOTE 5: Lock Time measured from power-up to stable output frequency.

### Typical Phase Noise at 125MHz

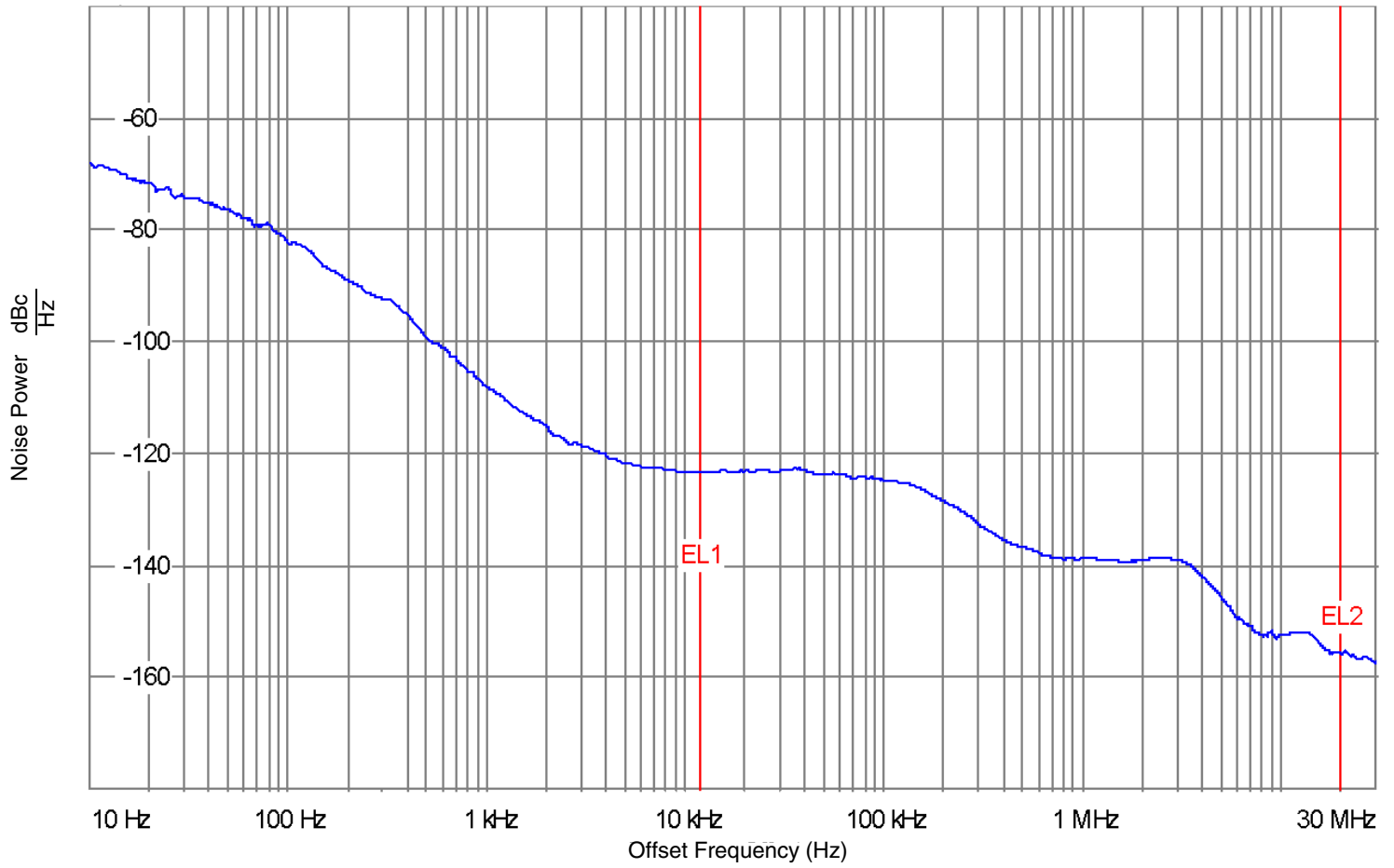

### Parameter Measurement Information

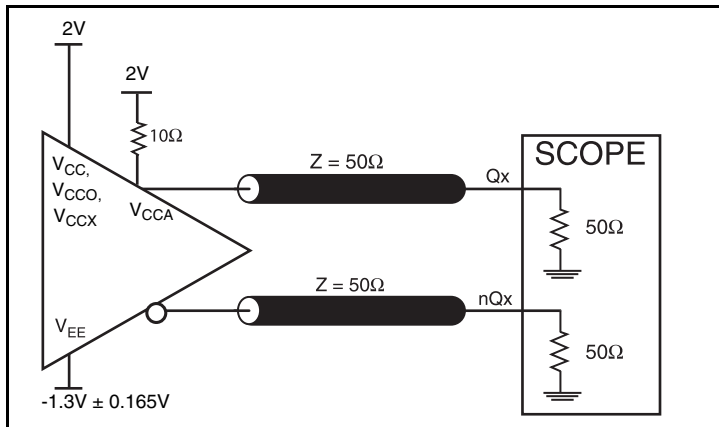

3.3V LVPECL Output Load AC Test Circuit

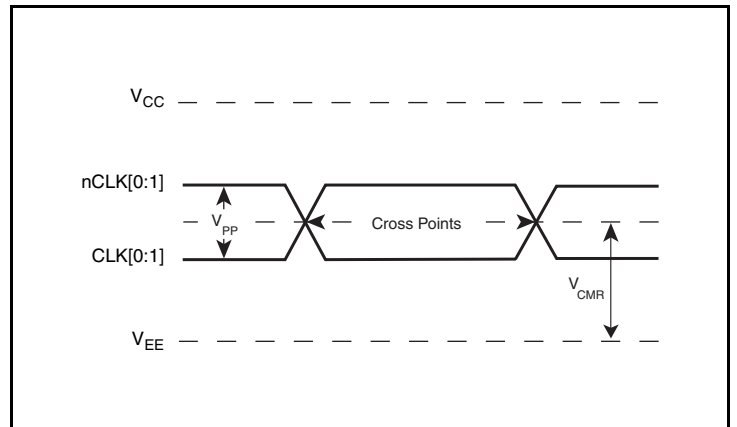

Differential Input Level

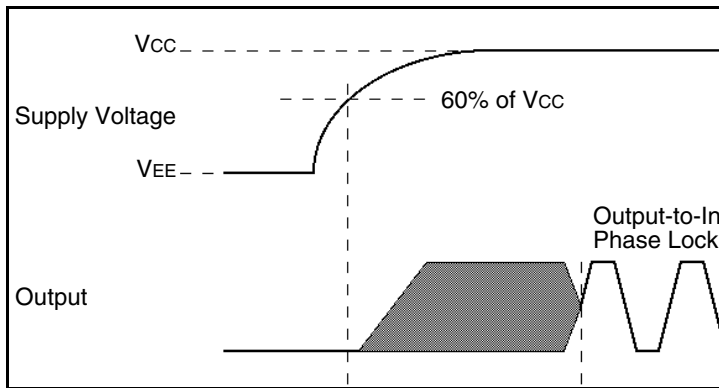

Output-to-Input Phase Lock Time

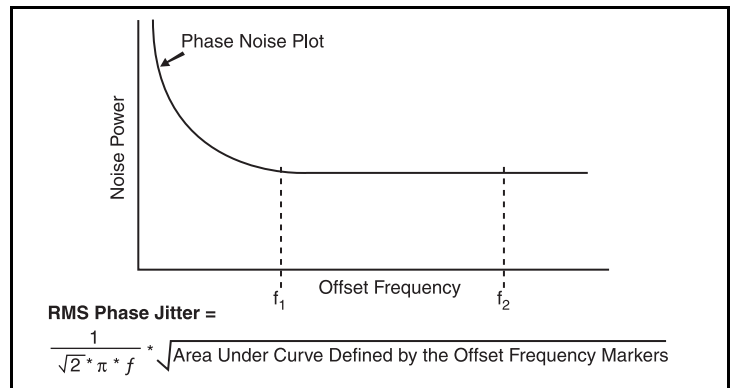

RMS Phase Jitter

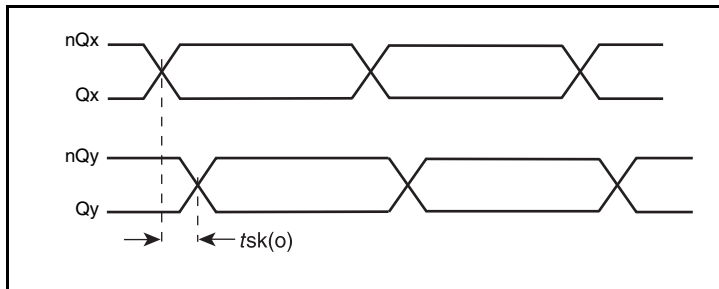

Output Skew

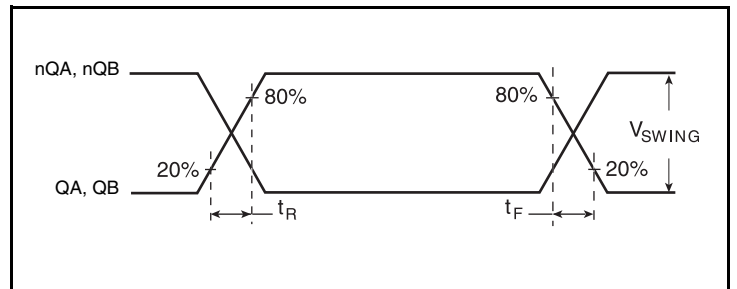

LVPECL Output Rise/Fall Time

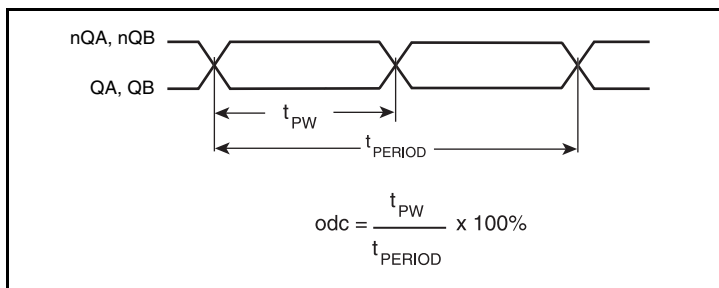

Output Duty Cycle/Pulse Width/Period

## Applications Information

### Wiring the Differential Input to Accept Single-Ended Levels

Figure 1 shows how a differential input can be wired to accept single ended levels. The reference voltage  $V_1 = V_{CC}/2$  is generated by the bias resistors R1 and R2. The bypass capacitor (C1) is used to help filter noise on the DC bias. This bias circuit should be located as close to the input pin as possible. The ratio of R1 and R2 might need to be adjusted to position the  $V_1$  in the center of the input voltage swing. For example, if the input clock swing is 2.5V and  $V_{CC} = 3.3V$ , R1 and R2 value should be adjusted to set  $V_1$  at 1.25V. The values below are for when both the single ended swing and  $V_{CC}$  are at the same voltage. This configuration requires that the sum of the output impedance of the driver ( $R_o$ ) and the series resistance ( $R_s$ ) equals the transmission line impedance. In addition, matched termination at the input will attenuate the signal in half. This can be done in one of two ways. First, R3 and R4 in parallel should equal the transmission line

impedance. For most 50Ω applications, R3 and R4 can be 100Ω. The values of the resistors can be increased to reduce the loading for slower and weaker LVCMOS driver. When using single-ended signaling, the noise rejection benefits of differential signaling are reduced. Even though the differential input can handle full rail LVCMOS signaling, it is recommended that the amplitude be reduced. The datasheet specifies a lower differential amplitude, however this only applies to differential signals. For single-ended applications, the swing can be larger, however  $V_{IL}$  cannot be less than -0.3V and  $V_{IH}$  cannot be more than  $V_{CC} + 0.3V$ . Though some of the recommended components might not be used, the pads should be placed in the layout. They can be utilized for debugging purposes. The datasheet specifications are characterized and guaranteed by using a differential signal.

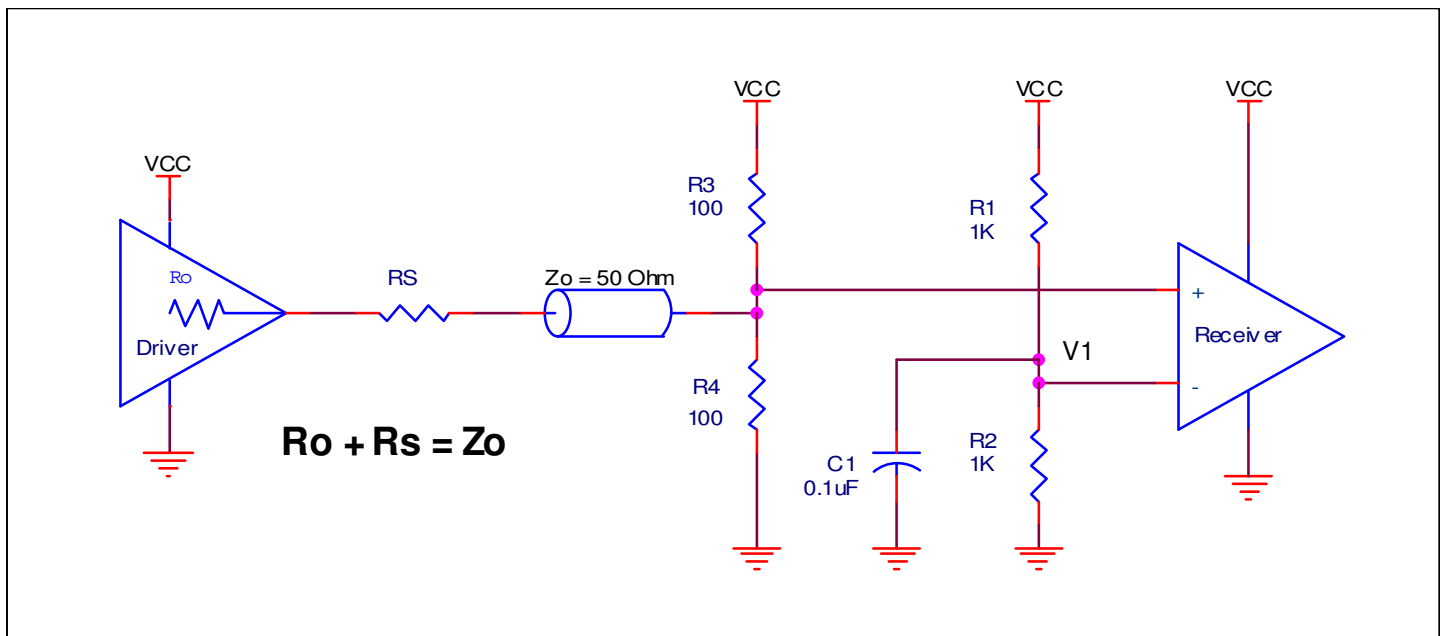
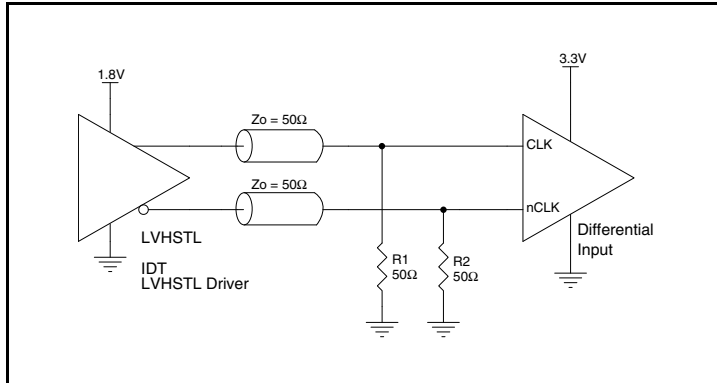

Figure 1. Recommended Schematic for Wiring a Differential Input to Accept Single-ended Levels

## Differential Clock Input Interface

The CLK /nCLK accepts LVDS, LVPECL, LVHSTL, HCSL and other differential signals. Both  $V_{SWING}$  and  $V_{OH}$  must meet the  $V_{PP}$  and  $V_{CMR}$  input requirements. *Figures 2A to 2E* show interface examples for the CLK/nCLK input driven by the most common driver types. The input interfaces suggested here are examples only. Please consult

with the vendor of the driver component to confirm the driver termination requirements. For example, in Figure 3A, the input termination applies for IDT open emitter LVHSTL drivers. If you are using an LVHSTL driver from another vendor, use their termination recommendation.



**Figure 2A. CLK/nCLK Input Driven by an IDT Open Emitter LVHSTL Driver**

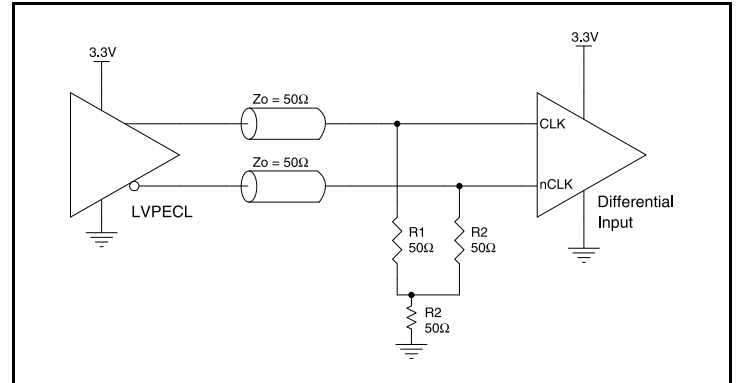

**Figure 2B. CLK/nCLK Input Driven by a 3.3V LVPECL Driver**

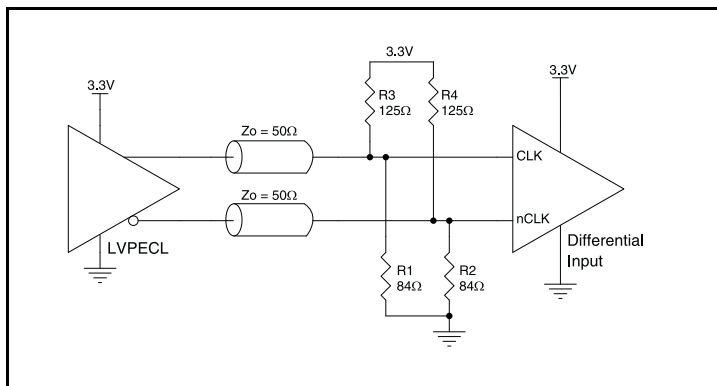

**Figure 2C. CLK/nCLK Input Driven by a 3.3V LVPECL Driver**

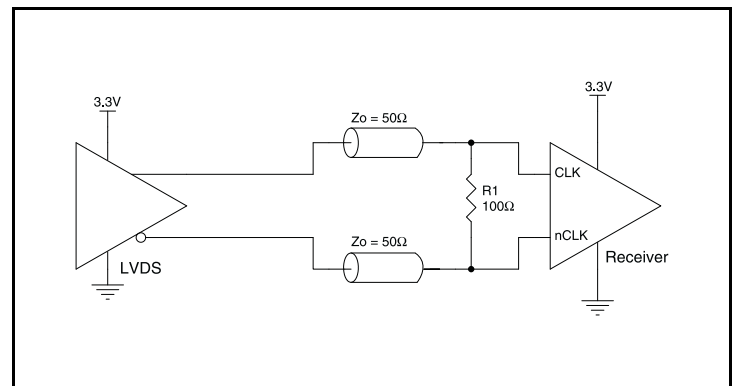

**Figure 2D. CLK/nCLK Input Driven by a 3.3V LVDS Driver**

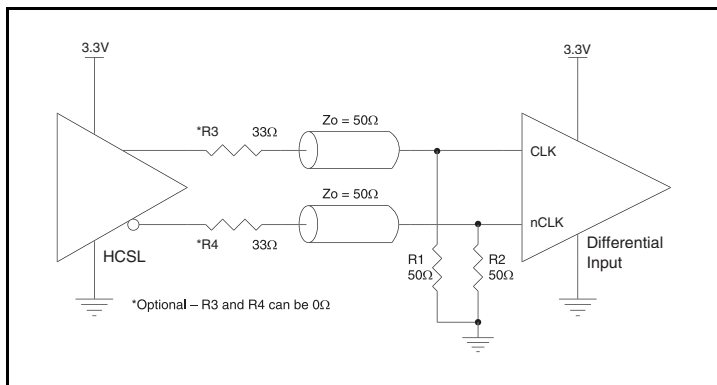

**Figure 2E. CLK/nCLK Input Driven by a 3.3V HCSL Driver**

## Recommendations for Unused Input and Output Pins

### Inputs:

#### CLK/nCLK Inputs

For applications not requiring the use of the differential input, both CLK and nCLK can be left floating. Though not required, but for additional protection, a 1kΩ resistor can be tied from CLK to ground.

#### LVC MOS Control Pins

All control pins have internal pullup or pulldown resistors; additional resistance is not required but can be added for additional protection. A 1kΩ resistor can be used.

### Outputs:

#### LVPECL Outputs

All unused LVPECL outputs can be left floating. We recommend that there is no trace attached. Both sides of the differential output pair should either be left floating or terminated.

## Termination for 3.3V LVPECL Outputs

The clock layout topology shown below is a typical termination for LVPECL outputs. The two different layouts mentioned are recommended only as guidelines.

The differential outputs are low impedance follower outputs that generate ECL/LVPECL compatible outputs. Therefore, terminating resistors (DC current path to ground) or current sources must be used for functionality. These outputs are designed to drive 50Ω

transmission lines. Matched impedance techniques should be used to maximize operating frequency and minimize signal distortion. *Figures 3A and 3B* show two different layouts which are recommended only as guidelines. Other suitable clock layouts may exist and it would be recommended that the board designers simulate to guarantee compatibility across all printed circuit and clock component process variations.

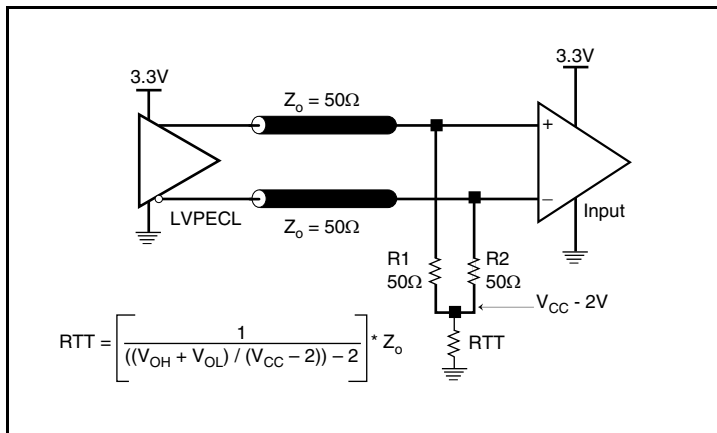

Figure 3A. 3.3V LVPECL Output Termination

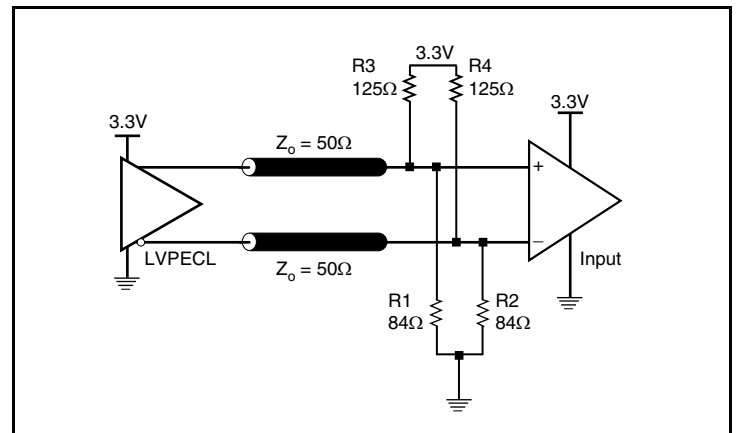

Figure 3B. 3.3V LVPECL Output Termination

## Jitter Attenuator EXTERNAL COMPONENTS

Choosing the correct external components and having a proper printed circuit board (PCB) layout is a key task for quality operation of the Jitter Attenuator. In choosing a crystal, special precaution must be taken with load capacitance ( $C_L$ ), frequency accuracy and temperature range.

The crystal's  $C_L$  characteristic determines its resonating frequency and is closely related to the center tuning of the crystal. The total external capacitance seen by the crystal when installed on a PCB is the sum of the stray board capacitance, IC package lead capacitance, internal device capacitance and any installed tuning capacitors (CTUNE). The recommended  $C_L$  in the Crystal Parameter Table balances the tuning range by centering the tuning curve for a typical PCB. If the crystal  $C_L$  is greater than the total external capacitance, the crystal will oscillate at a higher frequency than the specification. If the crystal  $C_L$  is lower than the total external capacitance, the crystal will oscillate at a lower frequency than the specification. Tuning adjustments might be required depending on the PCB parasitics or if using a crystal with a higher  $C_L$  specification.

In addition, the frequency accuracy specification in the crystal characteristics table are used to calculate the APR (Absolute Pull Range)

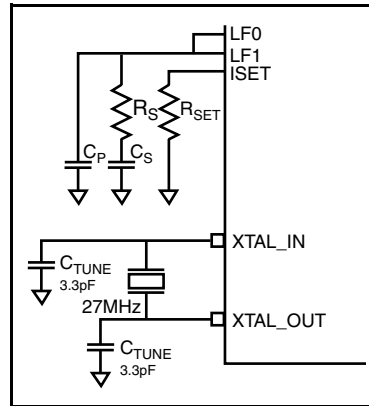

## Crystal Characteristics

Symbol	Parameter	Test Conditions	Minimum	Typical	Maximum	Units
	Mode of Oscillation		Fundamental			
$f_N$	Frequency			27		MHz
$f_T$	Frequency Tolerance				$\pm 20$	ppm
$f_S$	Frequency Stability				$\pm 20$	ppm
	Operating Temperature Range		0		+70	$^{\circ}\text{C}$
$C_L$	Load Capacitance			10		pF
$C_O$	Shunt Capacitance			4		pF
ESR	Equivalent Series Resistance				40	$\Omega$
	Drive Level				1	mW
	Aging @ 25 $^{\circ}\text{C}$	First Year			$\pm 3$	ppm

The VCXO-PLL Loop Bandwidth Selection Table shows  $R_S$ ,  $C_S$ ,  $C_P$  and  $R_{SET}$  values for recommended high, mid and low loop bandwidth configurations. The device has been characterized using these parameters. In addition, the digital VCXO gain ( $K_{VCXO}$ ) has been provided for additional loop filter requirements.

#### Jitter Attenuator Characteristics Table

Symbol	Parameter	Typical	Units
$k_{VCXO}$	VCXO Gain	2.78	kHz/V

#### Jitter Attenuator Loop Bandwidth Selection Table (2<sup>ND</sup> Order Loop Filter)

Bandwidth	Crystal Frequency	$R_S$ (k $\Omega$ )	$C_S$ ( $\mu$ F)	$C_P$ ( $\mu$ F)	R3 (k $\Omega$ )	C3 ( $\mu$ F)	$R_{SET}$ (k $\Omega$ )
15Hz (Low)	27MHz	215	10	0.022	0	DEPOP	2.74
30Hz (Mid)	27MHz	365	2.2	0.0047	0	DEPOP	2.74
60Hz (High)	27MHz	470	1	0.0022	0	DEPOP	1.5

NOTE: See Application schematic to identify loop filter components  $R_S$ ,  $C_S$ ,  $C_P$ , R3, C3 and  $R_{SET}$ .

For applications in which there is substantial low frequency jitter in the input reference and the phase detector frequency of 8kHz or 10kHz lies in or near a jitter mask, a three pole filter is recommended.

Suggested part values are in the table below. Note that the option of a three pole filter can be left open by laying out the three pole filter but setting R3 to 0 $\Omega$  and not populating C3. Refer to the application schematic for a specific example.

#### Jitter Attenuator Loop Bandwidth Selection Table (3<sup>RD</sup> Order Loop Filter)

Bandwidth	Crystal Frequency	$R_S$ (k $\Omega$ )	$C_S$ ( $\mu$ F)	$C_P$ ( $\mu$ F)	R3 (k $\Omega$ )	C3 ( $\mu$ F)	$R_{SET}$ (k $\Omega$ )
15Hz (Low)	27MHz	196	10	0.022	82.5	0.010	2.74
30Hz (Mid)	27MHz	392	2.2	0.0047	165	0.0022	2.74
60Hz (High)	27MHz	432	1	0.0022	182	0.001	1.5

NOTE: See Application schematic to identify loop filter components  $R_S$ ,  $C_S$ ,  $C_P$ , R3, C3 and  $R_{SET}$ .

The crystal and external loop filter components should be kept as close as possible to the device. Loop filter and crystal traces should be kept short and separated from each other. Other signal traces

should be kept separate and not run underneath the device, loop filter or crystal components.

### VFQFN EPAD Thermal Release Path

In order to maximize both the removal of heat from the package and the electrical performance, a land pattern must be incorporated on the Printed Circuit Board (PCB) within the footprint of the package corresponding to the exposed metal pad or exposed heat slug on the package, as shown in *Figure 4*. The solderable area on the PCB, as defined by the solder mask, should be at least the same size/shape as the exposed pad/slug area on the package to maximize the thermal/electrical performance. Sufficient clearance should be designed on the PCB between the outer edges of the land pattern and the inner edges of pad pattern for the leads to avoid any shorts.

While the land pattern on the PCB provides a means of heat transfer and electrical grounding from the package to the board through a solder joint, thermal vias are necessary to effectively conduct from the surface of the PCB to the ground plane(s). The land pattern must be connected to ground through these vias. The vias act as “heat pipes”. The number of vias (i.e. “heat pipes”) are application specific

and dependent upon the package power dissipation as well as electrical conductivity requirements. Thus, thermal and electrical analysis and/or testing are recommended to determine the minimum number needed. Maximum thermal and electrical performance is achieved when an array of vias is incorporated in the land pattern. It is recommended to use as many vias connected to ground as possible. It is also recommended that the via diameter should be 12 to 13mils (0.30 to 0.33mm) with 1oz copper via barrel plating. This is desirable to avoid any solder wicking inside the via during the soldering process which may result in voids in solder between the exposed pad/slug and the thermal land. Precautions should be taken to eliminate any solder voids between the exposed heat slug and the land pattern. Note: These recommendations are to be used as a guideline only. For further information, please refer to the Application Note on the Surface Mount Assembly of Amkor’s Thermally/Electrically Enhance Leadframe Base Package, Amkor Technology.

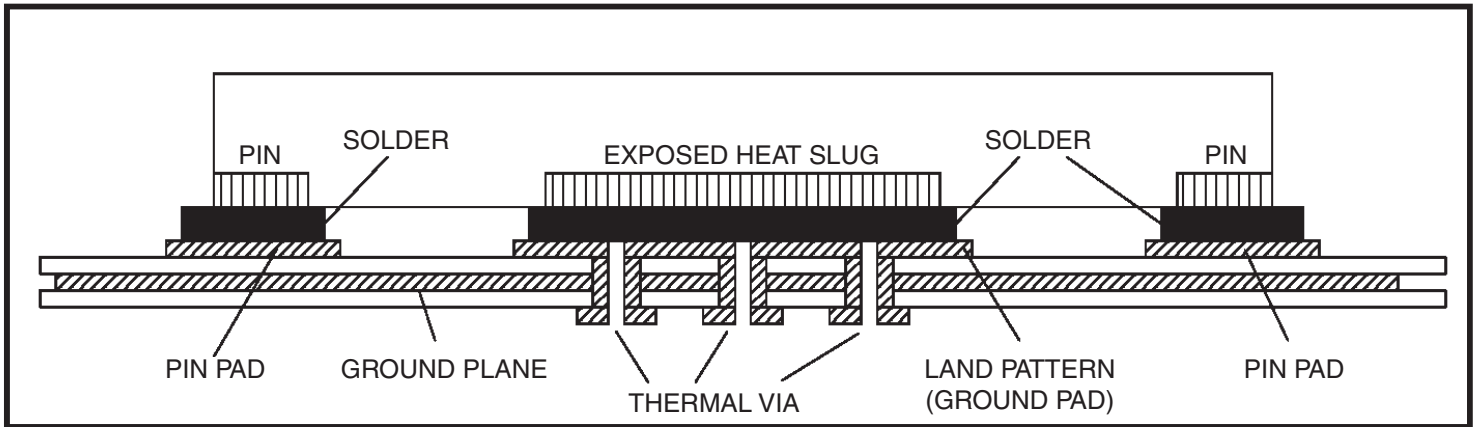

**Figure 4. P.C. Assembly for Exposed Pad Thermal Release Path – Side View (drawing not to scale)**

## Schematic Example

Figure 5 shows an example of the 813N2532 application schematic. In this example, the device is operated at  $V_{CC} = V_{CCA} = V_{CCX} = V_{CCO} = 3.3V$ . The inputs are driven by a 3.3V LVPECL driver and an LVDS driver. Two examples of LVPECL output terminations are shown in this schematic.

Selection of either the two pole or three pole filter is based on the application. A three pole loop filter is used for the greater reduction of 8kHz or 10kHz phase detector spurs relative to that afforded by a two pole loop filter. These spurs are generated when the input reference contains low frequency jitter in the pass band of the closed loop response. So for example if the 813N2532 is placed downstream from an IDT WAN PLL, then this jitter will not be present, allowing a two pole filter to be used. If however the 813N2532 is used to directly jitter attenuate a line recovered clock, then a three pole filter must be used. It is recommended that the loop filter components be laid out for the 3-pole option. With a three pole layout, the two pole filter option is preserved by depopulating C3 and setting  $R3 = 0$ . The loop filter components should be laid out on the 813N2532 side of the PCB directly adjacent to the LF0 and LF1 pins.

As with any high speed analog circuitry, the power supply pins are vulnerable to random noise. To achieve optimum jitter performance, power supply isolation is required. The 813N2532 provides separate

$V_{CC}$ ,  $V_{CCA}$ ,  $V_{CCX}$  and  $V_{CCO}$  power supplies for each jitter attenuator to isolate any high switching noise from coupling into the internal PLLs.

In order to achieve the best possible filtering, it is highly recommended that the 0.1uF capacitors on the device side of the ferrite beads be placed on the device side of the PCB as close to the power pins as possible. This is represented by the placement of these capacitors in the schematic. If space is limited, the ferrite beads, 10uF and 0.1uF capacitor connected to 3.3V can be placed on the opposite side of the PCB. If space permits, place all filter components on the device side of the board.

Power supply filter recommendations are a general guideline to be used for reducing external noise from coupling into the devices. The filter performance is designed for a wide range of noise frequencies. This low-pass filter starts to attenuate noise at approximately 10kHz. If a specific frequency noise component is known, such as switching power supplies frequencies, it is recommended that component values be adjusted and if required, additional filtering be added. Additionally, good general design practices for power plane voltage stability suggests adding bulk capacitance in the local area of all devices.

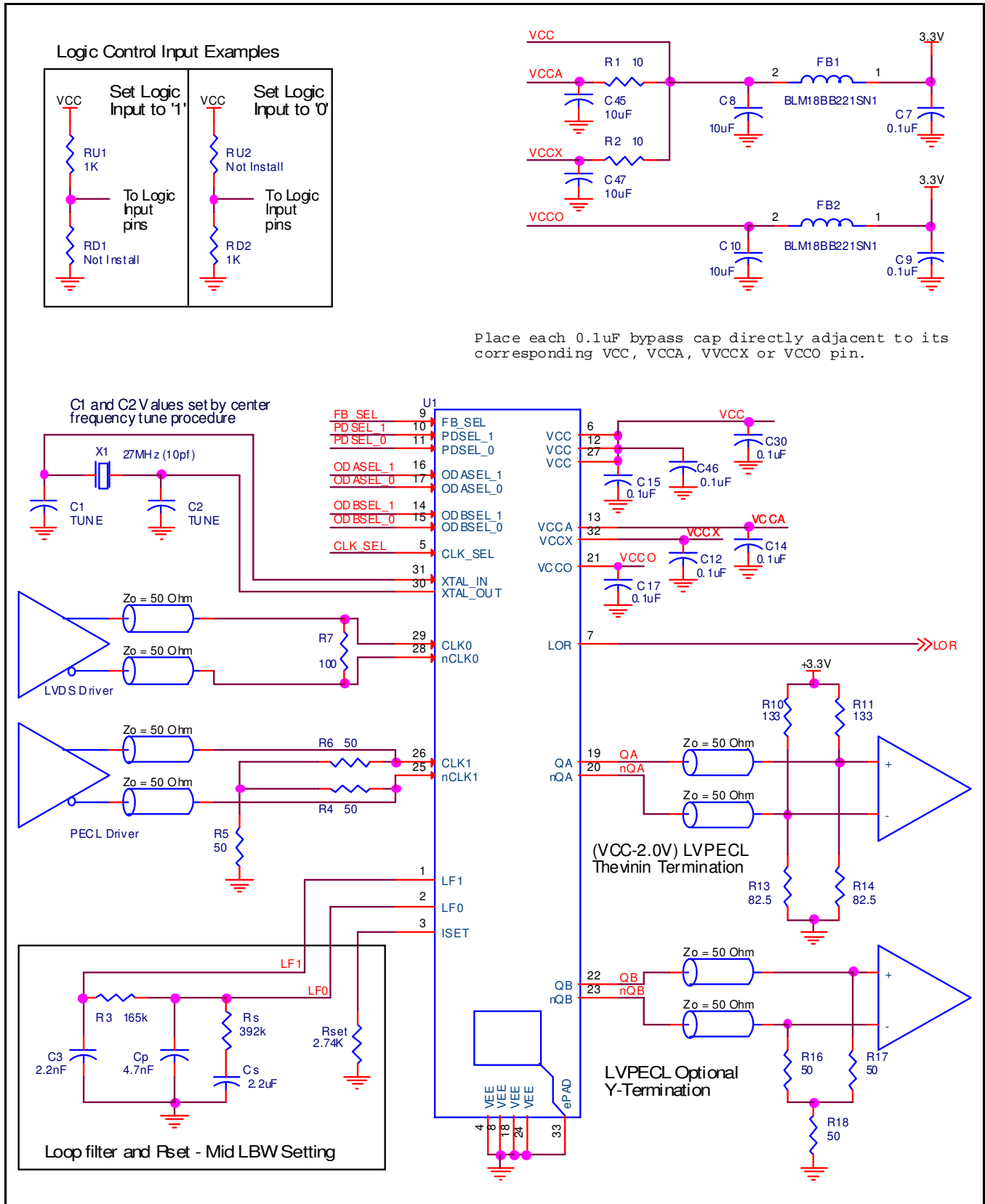

Figure 5. 813N2532 Schematic Example

## Power Considerations

This section provides information on power dissipation and junction temperature for the 813N2532. Equations and example calculations are also provided.

### 1. Power Dissipation.

The total power dissipation for the 813N2532 is the sum of the core power plus the power dissipated due to loading. The following is the power dissipation for  $V_{CCO} = 3.3V + 5\% = 3.465V$ , which gives worst case results.

NOTE: Please refer to Section 3 for details on calculating power dissipated due to loading.

- Power (core)<sub>MAX</sub> =  $V_{CCO\_MAX} * I_{EE\_MAX} = 3.465V * 312mA = \mathbf{1081.1mW}$
- Power (outputs)<sub>MAX</sub> = **31.55mW/Loaded Output pair**  
If all outputs are loaded, the total power is  $2 * 31.55mW = \mathbf{63.1mW}$

**Total Power**<sub>MAX</sub> (3.465V, with all outputs switching) =  $1081.1mW + 63.1mW = \mathbf{1144.2mW}$

### 2. Junction Temperature.

Junction temperature,  $T_j$ , is the temperature at the junction of the bond wire and bond pad directly affects the reliability of the device. The maximum recommended junction temperature is  $125^\circ C$ . Limiting the internal transistor junction temperature,  $T_j$ , to  $125^\circ C$  ensures that the bond wire and bond pad temperature remains below  $125^\circ C$ .

The equation for  $T_j$  is as follows:  $T_j = \theta_{JA} * Pd\_total + T_A$

$T_j$  = Junction Temperature

$\theta_{JA}$  = Junction-to-Ambient Thermal Resistance

$Pd\_total$  = Total Device Power Dissipation (example calculation is in section 1 above)

$T_A$  = Ambient Temperature

In order to calculate junction temperature, the appropriate junction-to-ambient thermal resistance  $\theta_{JA}$  must be used. Assuming no air flow and a multi-layer board, the appropriate value is  $33.1^\circ C/W$  per Table 6 below.

Therefore,  $T_j$  for an ambient temperature of  $70^\circ C$  with all outputs switching is:

$$70^\circ C + 1.1442W * 33.1^\circ C/W = 107.9^\circ C. \text{ This is below the limit of } 125^\circ C.$$

This calculation is only an example.  $T_j$  will obviously vary depending on the number of loaded outputs, supply voltage, air flow and the type of board (multi-layer).

**Table 6. Thermal Resistance  $\theta_{JA}$  for 32 Lead VFQFN, Forced Convection**

$\theta_{JA}$ by Velocity			
Meters per Second	0	1	3
Multi-Layer PCB, JEDEC Standard Test Boards	$33.1^\circ C/W$	$28.1^\circ C/W$	$25.4^\circ C/W$

### 3. Calculations and Equations.

The purpose of this section is to calculate the power dissipation for the LVPECL output pairs.

LVPECL output driver circuit and termination are shown in *Figure 6*.

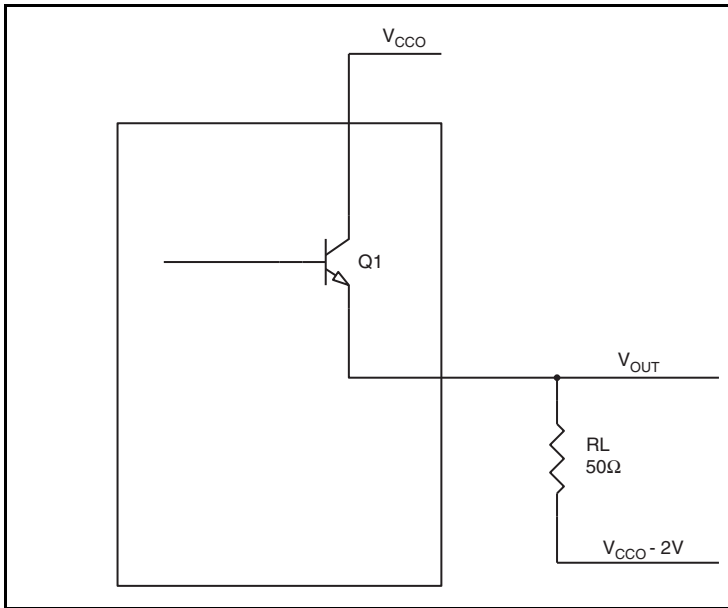

**Figure 6. LVPECL Driver Circuit and Termination**

To calculate power dissipation per output pair due to loading, use the following equations which assume a 50Ω load, and a termination voltage of  $V_{CCO} - 2V$ .

- For logic high,  $V_{OUT} = V_{OH\_MAX} = V_{CCO\_MAX} - 0.75V$   
 $(V_{CC\_MAX} - V_{OH\_MAX}) = 0.75V$
- For logic low,  $V_{OUT} = V_{OL\_MAX} = V_{CCO\_MAX} - 1.6V$   
 $(V_{CC\_MAX} - V_{OL\_MAX}) = 1.6V$

$Pd\_H$  is power dissipation when the output drives high.

$Pd\_L$  is the power dissipation when the output drives low.

$$Pd\_H = [(V_{OH\_MAX} - (V_{CCO\_MAX} - 2V))/R_L] * (V_{CCO\_MAX} - V_{OH\_MAX}) = [(2V - (V_{CCO\_MAX} - V_{OH\_MAX}))/R_L] * (V_{CCO\_MAX} - V_{OH\_MAX}) = [(2V - 0.75V)/50\Omega] * 0.75V = 18.75mW$$

$$Pd\_L = [(V_{OL\_MAX} - (V_{CCO\_MAX} - 2V))/R_L] * (V_{CCO\_MAX} - V_{OL\_MAX}) = [(2V - (V_{CCO\_MAX} - V_{OL\_MAX}))/R_L] * (V_{CCO\_MAX} - V_{OL\_MAX}) = [(2V - 1.6V)/50\Omega] * 1.6V = 12.80mW$$

$$\text{Total Power Dissipation per output pair} = Pd\_H + Pd\_L = 31.55mW$$

## Reliability Information

**Table 7.  $\theta_{JA}$  vs. Air Flow Table for a 32 Lead VFQFN**

$\theta_{JA}$ vs. Air Flow			
Meters per Second	<b>0</b>	<b>1</b>	<b>3</b>
Multi-Layer PCB, JEDEC Standard Test Boards	33.1°C/W	28.1°C/W	25.4°C/W

## Transistor Count

The transistor count for 813N2532 is: 44,795

# Package Outline and Package Dimensions

## Package Outline - K Suffix for 32 Lead VFQFN

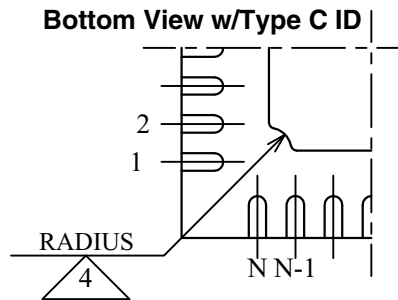
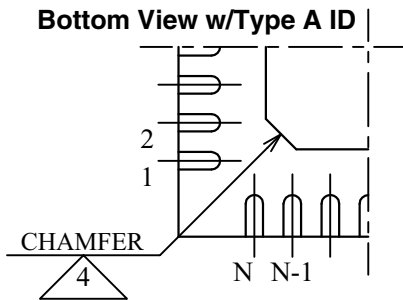
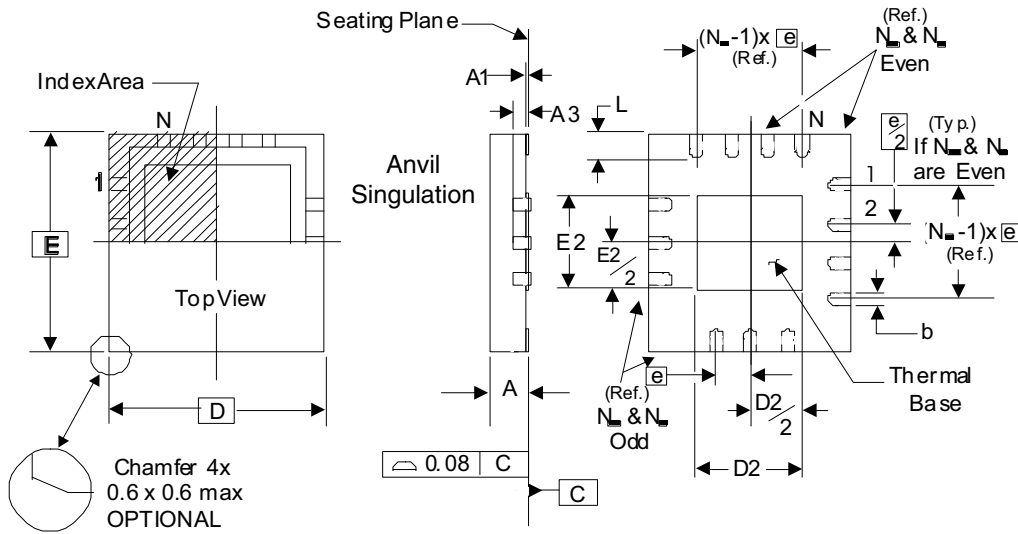

There are 2 methods of indicating pin 1 corner at the back of the VFQFN package:

1. Type A: Chamfer on the paddle (near pin 1)
2. Type C: Mouse bite on the paddle (near pin 1)

**Table 8. Package Dimensions**

JEDEC Variation: VHHD-2/-4 All Dimensions in Millimeters			
Symbol	Minimum	Nominal	Maximum
N	32		
A	0.80		1.00
A1	0		0.05
A3	0.25 Ref.		
b	0.18	0.25	0.30
$N_D$ & $N_E$	8		
D & E	5.00 Basic		
D2 & E2	3.0		3.3
e	0.50 Basic		
L	0.30	0.40	0.50

NOTE: The following package mechanical drawing is a generic drawing that applies to any pin count VFQFN package. This drawing is not intended to convey the actual pin count or pin layout of this device. The pin count and pin-out are shown on the front page. The package dimensions are in Table 8.

Reference Document: JEDEC Publication 95, MO-220

## Ordering Information

Table 9. Ordering Information

Part/Order Number	Marking	Package	Shipping Packaging	Temperature
813N2532CKLF	ICS3N2532CL	"Lead-Free" 32 Lead VFQFN	Tray	0°C to 70°C
813N2532CKLFT	ICS3N2532CL	"Lead-Free" 32 Lead VFQFN	Tape & Reel	0°C to 70°C

## Revision History Sheet

Rev	Table	Page	Description of Change	Date
B		5 2	Supply Voltage, $V_{CC}$ . Rating changed from 4.5V min. to 3.63V per Errata NEN-11-03. Correct typo in block diagram from /2 to /3 for PDSEL[2:0].	6/01/11
B		1 2 11	Features Section, deleted SSTL for the Two differential inputs bullet. Corrected block diagram from /3 back to /2 on the PDSEL[1:0]. Removed the connection between the FB_SEL line and the PDSEL[1:0] line. Clock Input Interface Section, deleted all references to SSTL	6/03/11
C	T4A T5	1 5 7 13 16 17 18 19	Features: Updated RMS Phase Jitter data to reflect RMS Phase Jitter data in Table 5 Analog Supply Voltage. Changed from $V_{CC}$ -0.31V to $V_{CC}$ -0.29V, Power Supply Current changed from 300mA to 312mA, Analog Supply Current changed from 31mA to 29mA. RMS Phase Jitter, 156.25MHz changed 0.6ps to 0.64ps, RMS Phase Jitter, 155.52MHz changed 0.622ps to 0.644ps, RMS Phase Jitter, 125MHz changed 0.6ps to 0.66ps. Jitter Attenuator Char Table: changed $k_{VCXO}$ - 2.79 kHz/V Typical to 2.02 Typical kHz/V Power Considerations: changed IEE_MAX = 300mA to 312mA; 1039.55mW to 1081.1mW; Total Power_MAX CHANGED 1039.55mW to 1081.1mW, 1102.65mW 1144.2mW. Tj changed 1.103W and 106.5C to 1.1442W and 107.9C. Changed text: "To calculate worst case power dissipation into the load" to "To calculate power dissipation per output pair due to loading". Changed transistor count from 44,832 to 44,795. Changed part order number and marking from Rev A to Rev C. Deleted count for Tape and Reel. Deleted Lead-Free note.	8/3/12
C		10 14 17, 18	Updated Wiring the Differential Input to Accept Single-Ended Levels text and schematic. Jitter Attenuator Characteristics Table: $k_{VCXO}$ 2.78kHz/V. Added Jitter Attenuator Loop Bandwidth Selection Tables: 2 <sup>nd</sup> and 3 <sup>rd</sup> Order Loop Filter. Replaced text and schematic.	9/21/12
C		10 14	Applications Information - deleted <i>Power Supply Filtering Techniques</i> application note. It is included in the schematic example on page 17. Jitter Attenuator Loop Bandwidth Selection Table (3 <sup>RD</sup> Order Loop Filter): corrected C3 (k $\Omega$ ) heading to C3( $\mu$ F).	10/2/13
D			Deleted "ICS" prefix from part number through out the datasheet. Updated datasheet header/footer.	4/8/16



**Corporate Headquarters**  
6024 Silver Creek Valley Road  
San Jose, CA 95138 USA

**Sales**  
1-800-345-7015 or 408-284-8200  
Fax: 408-284-2775  
www.IDT.com

**Tech Support**  
email: [clocks@idt.com](mailto:clocks@idt.com)

DISCLAIMER Integrated Device Technology, Inc. (IDT) and its subsidiaries reserve the right to modify the products and/or specifications described herein at any time and at IDT's sole discretion. All information in this document, including descriptions of product features and performance, is subject to change without notice. Performance specifications and the operating parameters of the described products are determined in the independent state and are not guaranteed to perform the same way when installed in customer products. The information contained herein is provided without representation or warranty of any kind, whether express or implied, including, but not limited to, the suitability of IDT's products for any particular purpose, an implied warranty of merchantability, or non-infringement of the intellectual property rights of others. This document is presented only as a guide and does not convey any license under intellectual property rights of IDT or any third parties.

IDT's products are not intended for use in applications involving extreme environmental conditions or in life support systems or similar devices where the failure or malfunction of an IDT product can be reasonably expected to significantly affect the health or safety of users. Anyone using an IDT product in such a manner does so at their own risk, absent an express, written agreement by IDT.

While the information presented herein has been checked for both accuracy and reliability, Integrated Device Technology (IDT) assumes no responsibility for either its use or for the infringement of any patents or other rights of third parties, which would result from its use. No other circuits, patents, or licenses are implied. This product is intended for use in normal commercial applications. Any other applications, such as those requiring extended temperature ranges, high reliability or other extraordinary environmental requirements are not recommended without additional processing by IDT. IDT reserves the right to change any circuitry or specifications without notice. IDT does not authorize or warrant any IDT product for use in life support devices or critical medical instruments.

Integrated Device Technology, IDT and the IDT logo are registered trademarks of IDT. Product specification subject to change without notice. Other trademarks and service marks used herein, including protected names, logos and designs, are the property of IDT or their respective third party owners.

Copyright ©2016 Integrated Device Technology, Inc. All rights reserved.