

# LOW DISTORTION LINE MATCHING TRANSFORMER

# P3801

## Features

- \* Lead-free (Pb-free)
- \* RoHS compliant
- \* Low distortion
- \* Environmentally tested to IEC 68
- \* CERT reliability tested
- \* 12.6mm (0.5") seated height
- \* Industry Standard Pinout
- \* Extended Frequency Response
- \* IEC 60950 and UL 1950 Certified
- \* UL Recognized Component
- \* High thermal stability

## Applications

- \* V.90 and V.92 modems
- \* V.34 modems

## DESCRIPTION

P3801 is intended for high-speed applications where low distortion at moderate power levels and very low voiceband frequencies is required at the most competitive price. At moderate power levels (e.g. -10dBm) performance to V.90/V.92 may be achieved.

P3801 has extended flat frequency response from 30Hz to 4kHz with very low levels of signal distortion at signal frequencies as low as 150Hz.

P3801 is electrically and mechanically compatible with P3034 and P2001 for supplementary insulation 250V working applications, and directly replaces 9002VF, 671-8236M, MTLM 2001, EMIT-2001, and ATS-091/B without changes to matching components, but with the added benefit of considerably improved thermal stability. P3801 also offers a drop-in performance upgrade path for P3800 and P1200.

P3801 uses patented design and construction methods to achieve excellent signal performance and safety isolation to international standards. The part is completely lead-free, compliant with RoHS Directive 2002/95/EC, and suitable for lead-free and conventional processing.

P3801 is certified to IEC 60950 and UL 60950. P3801 is a UL Recognized Component and is supported by an IEC CB Test Certificate.

P3801 is a rugged lightweight design that has been subjected to relevant environmental testing according to IEC 68 and Combined Environmental Reliability Testing (CERT) beyond normal operational levels and passed all tests, remaining fully functional.

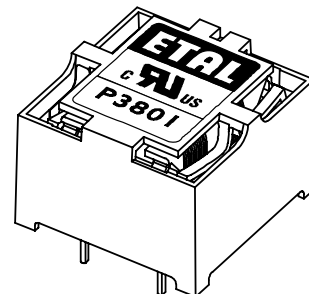

## SPECIFICATIONS

### Electrical

At T = 25°C and as circuit fig. 2 unless otherwise stated.

Parameter	Conditions	Min	Typ	Max	Units
Insertion Loss	f = 2kHz, R <sub>L</sub> = 560Ω	-	-	1.5	dB
Frequency response	200Hz - 4kHz	-	-	±0.2	dB
Return Loss	200Hz - 4kHz	18	-	-	dB
Third Harmonic Distortion <sup>(1)</sup>	150Hz - 10dBm	-	-90	-	dBm
	600Hz - 10dBm	-	-100	-	dBm
Voltage isolation <sup>(2)</sup>	50Hz	2.12	-	-	kVrms
	DC	3.0	-	-	kV
Operating range: Functional Storage	Ambient temperature	0	-	+70	°C
		-40	-	+85	°C

Lumped equivalent circuit parameters as Fig. 1

DC resistance, R <sub>DC</sub> <sup>(3)</sup>	Sum of windings	120	-	148	Ω
Leakage inductance ΔL		16	-	19.5	mH
Shunt inductance L <sub>p</sub> <sup>(4)</sup>	10mV 200Hz	6	-	-	H
Shunt loss R <sub>p</sub> <sup>(4)</sup>	10mV 200Hz	12	-	-	kΩ

### Notes

1. Third harmonic typically exceeds other harmonics by 20dB.
2. Components are 100% tested at 3.25kV DC.
3. Caution: do not pass DC through windings. Telephone line current, etc. must be diverted using choke or semiconductor line hold circuit.
4. At signal levels greater than 100mV, L<sub>p</sub> will increase and R<sub>p</sub> will decrease slightly but the effect is usually favourable to the return loss characteristic.

### Equivalent Circuit

Fig. 1

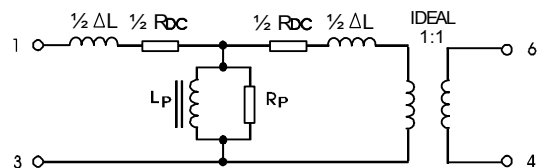

Patented

**MATCHING RECOMMENDATIONS**

**600Ω MATCH**

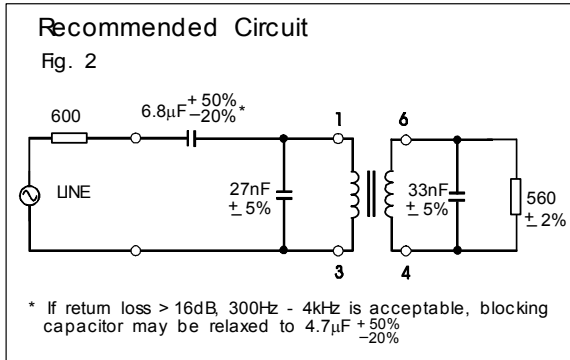

**EUROPEAN CTR21 COMPLEX MATCH**

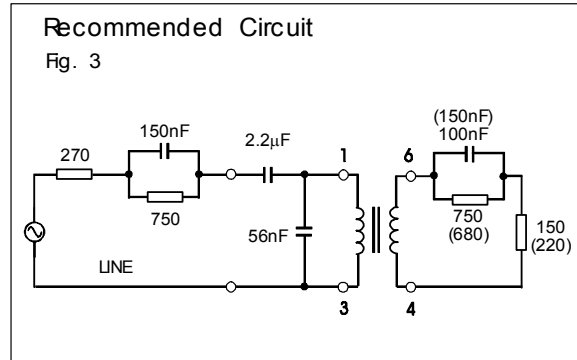
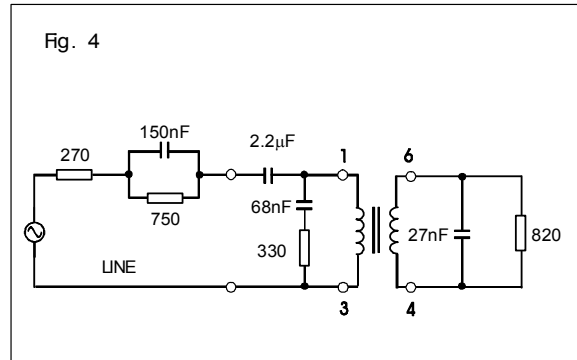
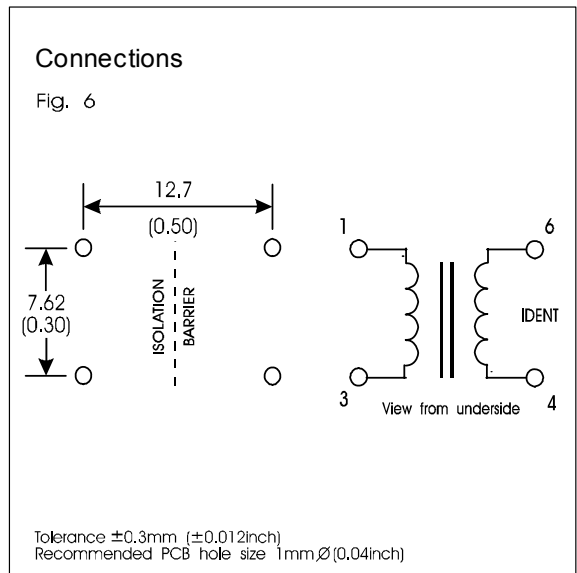
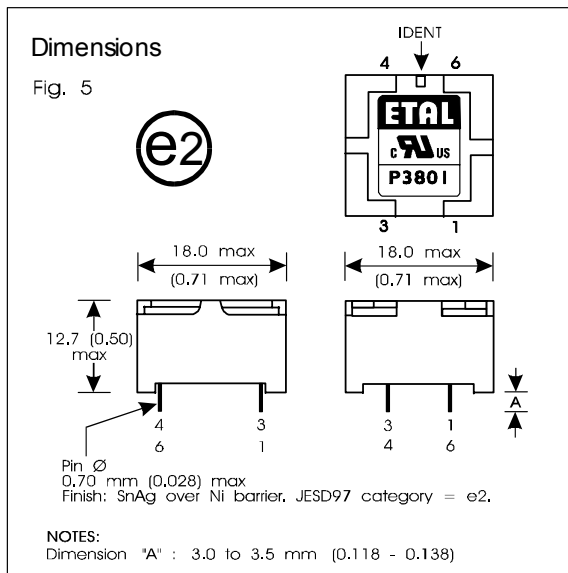

Figure 3 gives flat RX and TX responses against the CTR21 complex reference impedance (typically around  $\pm 0.5\text{dB}$  300Hz - 3.4kHz). Return loss is typically better than 20dB. The circuit values in parentheses give optimum flatness at a small sacrifice in return loss.

For circuits with existing board drillings, figure 4 gives good return loss (>20dB) and RX flatness against the CTR21 complex reference impedance, but TX flatness is degraded by the use of this topology.



**CONSTRUCTION**



Dimensions shown are in millimetres (inches).  
Geometric centres of outline and pin grid coincide within a tolerance circle of 0.6mm  
Windings may be used interchangeably as primary or secondary.

## ENVIRONMENTAL TESTING

### Reliability testing to IEC 68

Tested to clauses of IEC 68 and compliant with all functional and safety requirements following exposure as follows:

Test description	IEC 68 reference	Test details	Result
Robustness of terminations	68-2-21 Test Ua <sub>1</sub> 68-2-21 Test Ua <sub>2</sub>	Tensile 5N pull Thrust 1N push	No impairment No pin detachment or distortion
Solderability	68-2-20 Test Ta Method 1	Solder bath 235°C 2s	No impairment Finish smooth, bright and even
Resistance to soldering heat	68-2-20 Test Tb Method 1A 68-2-20 Test Tb Method 2	Solder bath 260°C 10s Soldering iron 350°C 5s	
Vibration	68-2-6 Test Fc	Sweep 10-55-10Hz in 1 minute Amplitude 1.5mm pk-pk Duration 2h per axis, 3 axes	No impairment
Shock	68-2-27 Test Ea	Peak acceleration 1000m/s <sup>2</sup> Duration of pulse 6ms 3 shocks each direction on 3 axes	No impairment
Cold	68-2-1 Test Ab	-25°C 16h Recovery to ambient 1-2h	No impairment
Dry heat	68-2-2 Test Bb	125°C 16h Recovery to ambient 1-2h	No impairment
Damp heat	68-2-3 Test Ca	40°C 4 days, RH 93% Recovery to ambient 1-2h	No impairment
Change of temperature	68-2-14 Test Na	T <sub>A</sub> -25°C T <sub>B</sub> +85°C t <sub>1</sub> 30 min 2 min ≤ t <sub>2</sub> ≤ 3 min Recovery to ambient 1-2h 5 cycles	No impairment

### Combined Environmental Reliability Testing (CERT)

Components step stressed at increasing levels of severity using combined stresses to detect potential weaknesses. Results are shown for highest levels of stress tested. Compliant with all functional and safety tests following exposure as follows:

Test description	Test details	Duration	Result
Storage Test	Thermal cycling -30°C to +100°C at 11°C/min 6mm pk 2-9Hz at 1 octave/min 20m/s <sup>2</sup> 9-200Hz	20 mins per plane	No impairment
Transportation Test	Thermal cycling -65°C to +80°C Random vibration 10-200Hz and 200-2000Hz at 57m/s <sup>2</sup> RMS	2 hours per plane	No impairment

## SAFETY

Constructed in accordance with IEC 60950-1, EN 60950-1 and UL 60950-1, supplementary insulation, 250Vrms maximum working voltage, flammability class V-0.

There are no special installation requirements (beyond attending to usual PCB track separations) since the integral cover provides supplementary insulation from its external faces to internal core and windings.

## CERTIFICATION

Certified under the IEC CB scheme (Certificate DK-8570) to IEC 60950-1-2001, sub-clauses 1.5, 1.5.1, 1.5.2, 1.7.1, 2.9, 2.9.1, 2.9.2, 2.9.3, 2.10, 2.10.1, 2.10.2, 2.10.3, 2.10.3.1, 2.10.3.3, 2.10.4, 2.10.5, 2.10.5.1, 2.10.5.2, 2.10.5.4, 4.7, 4.7.1 (classV-1), 4.7.3, 4.7.3.1, 4.7.3.4, 5.2, 5.2.1, 5.2.2, 6.1.2.1 (Finland, Norway, Sweden national deviations) for a maximum working voltage of 250Vrms, nominal mains supply voltage not exceeding 300Vrms and a maximum operating temperature of 70°C in Pollution Degree 2 environments.

Recognized under the Component Recognition Program of Underwriters Laboratories Inc. to US and Canadian requirements CAN/CSA C22.2 No. 60950-1-03/UL60950-1, First Edition, based on IEC 60950-1, First Edition, maximum working voltage 250Vrms, Pollution Degree 2, supplementary insulation.

UL File number E203175.

Additionally, Profec Technologies certifies all transformers as providing voltage isolation of 2.12kVrms, 3kV DC minimum. All shipments are supported by a certificate of conformity to current applicable safety standards.

## ABSOLUTE MAXIMUM RATINGS

(Ratings of components independent of circuit).

Short term isolation voltage (1s)	2.12kVrms 3.0kVDC
DC current	100µA
Storage temperature	-40°C to +85°C
Lead temperature, 10s	260°C

## INTELLECTUAL PROPERTY RIGHTS

ETAL, P1200, P2001, P3034, P3800 and P3801 are Trade Marks of Profec Technologies Ltd. The Trade Mark ETAL is registered at the UK Trade Marks Registry.

Profec Technologies Ltd. is the owner of the design right under the Copyright Designs and Patents Act 1988 and no rights or licences are hereby granted or implied to any third party.

P3189 design and construction are protected by patents and registered design.  
UK Registered Design No. 2077360.  
US Patent No. 6,690,254  
French Registered Design No. 991512.  
United States Registered Design 426, 815.  
Mexico Registered Design 12143.  
Other patents and registered designs pending.

© 1998 - 2005 Profec Technologies Ltd.  
Reproduction prohibited.



ISO 9001  
FM 25326

ETAL Group Oy, Kuormatie 14, FIN-03101, Nummela  
Telephone: +358 (0)20 7500 330 Fax: +358 (0)20 7500 333  
Website: [www.etalgroup.com](http://www.etalgroup.com) Email: [etalgroup@egruppen.com](mailto:etalgroup@egruppen.com)