

ATLANTIC VERSION TERMINATOR INTERFACE ADAPTER	PART NUMBER	REVISION	DESCRIPTION	FEED TYPE	APPLICATOR STYLE CONVERSION CHART					
					CONVERT TO	PART NUMBERS REQUIRED				
	2150022-2	B	FINE CRIMP HEIGHT ADJUST	PNEUMATIC	-	-	-	-	-	-
					SERVO LATCH PLATE	2119951-1	1901697-1	8-2150022-5	-	2168400-7 (QUANTITY 2)
					SMART APPLICATOR	2161326-1	-	8-2150022-4	-	-
	2150022-5	B	FINE CRIMP HEIGHT ADJUST	SERVO LATCH PLATE ⁴	-	-	-	-	-	-
					PNEUMATIC FEED	2119950-1	2119792-1	-	2119641-1	2063440-2
	2150022-6	B	NON-CRIMP HEIGHT ADJUST	SERVO LATCH PLATE ⁴ ¹²	-	-	-	-	-	-
	2150022-7	B	FINE CRIMP HEIGHT ADJUST	NONE	-	-	-	-	-	-
7-2150022-7	A	CRIMP TOOLING KIT	-	-	-	-	-	-	-	

APPLICATOR DATA		
CRIMP	SIZE	TYPE
WIRE	2.29 mm [.090]	F
INSUL	4.06 mm [.160]	F
APPL INSTRUCTIONS 408-10390		

TERMINAL DATA: TE TERMINAL TE CRIMP SPECIFICATION			
TERMINAL NAME: RING TONGUE			
WIRE STRIP LENGTH		INSULATION DIAMETER RANGE	
4.80-5.60 mm [.189-.220 IN]		Ø2.00-3.30 mm [.079-.130 IN]	
TERMINAL APPLICATION SPECIFICATION	114-3118	-	-
TERMINALS APPLIED ¹³			
TE TERMINAL	TE TERMINAL	TE TERMINAL	TE TERMINAL
880628-1	880628-2	880630-1	880630-2

WIRE SIZE	CRIMP HEIGHT mm [INCH]	CRIMP HEIGHT REFERENCE SETTING ⁹
1.00mm2	1.98 +/- 0.05 [.078 +/- .002]	6.5
0.75mm2	1.93 +/- 0.05 [.076 +/- .002]	7.0
0.50mm2	1.88 +/- 0.05 [.074 +/- .002]	7.5

- ¹ RECOMMENDED SPARE PARTS
- ² GREASE BEARING SURFACES LIGHTLY
- 3. LUBRICATE DAILY PER THE APPLICATOR INSTRUCTION SHEET SUPPLIED WITH THE APPLICATOR.
- ⁴ APPLICATOR SPECIFIC DATA TO BE ENTERED INTO BLANK MEMORY CHIP AT ASSEMBLY. SEE BELOW FOR PART NUMBER:
 PNEUMATIC FEED WITH "SMART APPLICATOR" CONVERSION: 8-2150022-4
 SERVO FEED WITH "FINE CRIMP HEIGHT ADJUST": 8-2150022-5
 SERVO FEED WITH "NON-CRIMP HEIGHT ADJUST": 8-2150022-6
- 5. ADJUSTMENT OF THE STRIPPER MAY BE REQUIRED WHEN MOVING THE APPLICATOR BETWEEN BENCH AND LEADMAKER APPLICATIONS.
- ⁶ APPLY PART NUMBER 1-23419-5 LOCTITE TO THREADS OF ITEMS 62. APPLY PART NUMBER 2-23419-6 LOCTITE TO THREADS OF ITEMS 242. FOR -6 ONLY APPLY PART NUMBER 1-23419-5 LOCTITE TO THREADS OF ITEM 37.
- ⁷ GREASE THREADS, GROOVE AND O-RING ON ITEMS 35 & 252.
- ⁸ MAGNET, ITEM 166 MUST BE ORIENTED CORRECTLY IN ORDER TO PROPERLY ACTUATE THE COUNTER.
- ⁹ CRIMP HEIGHT REFERENCE SETTING WAS THE SETTING USED WHEN THE APPLICATOR WAS QUALIFIED AT THE FACTORY. ADJUSTMENT MAY BE NECESSARY WHEN RUNNING APPLICATOR IN THE FIELD.
- ¹⁰ CUT TO LENGTH AT ASSEMBLY.
- ¹¹ THE RECOMMENDED SET-UP FOR END FEED APPLICATORS IS POST-FEED WITH ITEM 2119653-1. THE APPLICATOR CAN BE CONFIGURED FOR PRE-FEED WITH ITEM 2119652-1 BUT MAY ENCOUNTER PROBLEMS WITH SOME APPLICATIONS. FEED ISSUES OR TERMINAL JAMMING MAY OCCUR IN THE PRE-FEED CONFIGURATION.
- ¹² WHEN ASSEMBLING -6 NON-CRIMP HEIGHT ADJUST APPLICATOR USE SHIM PACK 2119957-2 TO ALIGN APPLICATOR'S MAXIMUM WIRE CRIMP HEIGHT AT NORMAL TERMINATOR SHUT HEIGHT
- ¹³ TERMINAL PITCH NOT COMPATIBLE WITH MECHANICAL FEED.

***WARNING**
 ON INSTALLATION, SET WIRE DISC, ITEM 40 TO LARGEST WIRE SIZE SETTING. USE OF SETTINGS BELOW MINIMUM REQUIRED CRIMP HEIGHT SETTING WILL CAUSE DAMAGE TO CRIMP TOOLING.

SET UP GAUGE	LOC	DIST	REVISIONS					
2119599-2	A	66	P	LTN	DESCRIPTION	DATE	DWN	APVD
			B		ECR-15-006496	24APR2015	MR	TE

-	-	1	-	-	2119957-2	APPLICATOR SHIM PACK	260
-	1	-	1	1	8-21084-0	O-RING, .676 ID, .070 DIA. MAT.	252
-	-	-	-	1	2119640-1	PUSH ROD, AIR FEED	250
-	-	-	-	1	2079988-1	BUSHING, LCH5-12, MISUMI	249
-	-	-	-	1	2119641-1	FEED CAM, AIR FEED	248
-	1	-	1	1	2119798-1	DETENT PIN	247
-	1	-	1	1	1-22279-3	SPRING, COMPRESSION	246
-	-	1	-	-	2119759-1	RAM, AMP STYLE, END FEED, NON-ADJUST	245
-	1	1	1	1	2119082-9	CAM, SNAIL, INSULATION ADJUSTMENT	244
-	1	1	1	1	2079764-1	WASHER, WAVE SPRING, CREST-TO-CREST	243
-	1	1	1	1	2119083-1	RETAINER, INSULATION DIAL	242
-	-	2	2	-	2168400-7	SHCS, LOW HEAD, RoHS, M5 X 10	240
-	-	-	-	1	2063440-2	AIR FEED MODULE	238
-	-	1	1	-	2119740-2	TAG, IDENTIFICATION	213
-	-	REFREF	-	-	1901697-1	FEED FINGER ASSEMBLY, EF	183
-	-	-	-	2	21045-3	RING, RETAIN, EXTERN, 3/16 CRESCENT	172
-	1	1	1	1	994969-1	MAGNET, RARE EARTH HIGH ENERGY	166
-	REFREF	REFREF	REFREF	REFREF	994970-2	COUNTER, MAGNETIC	164
-	-	-	-	1	240638-1	SPRING, FEED FINGER	163
-	-	-	-	1	3-23627-7	PIN, RETAIN, GRVD, 3/16 X .854	137
-	-	REFREF	-	-	SEE NOTE 4	MEMORY CHIP, PROGRAMMED	135
-	-	1	1	-	1633743-1	SERVO FEED LATCH ASM	133
-	1	1	1	1	455888-5	SPACER, CRIMPER	82
-	1	1	1	1	2119956-2	DOCUMENTATION PACKAGE	71
-	2	2	2	2	2-18032-2	SCR, SET, FLT POINT M3 X 10.0	70
-	1	-	-	1	2119740-1	TAG, IDENTIFICATION	67
-	2	2	2	2	2168078-1	SCREW, DRIVE, RH, RoHS, 2 x .188	66
-	1	-	1	1	2119793-1	LIMITER, ADJUSTMENT BOLT	63
-	3	-	3	3	992763-5	SCR, SET, SOC, CONE POINT, M3 x 4.0	62
-	1	1	1	1	2079383-4	SCR, BHSC, RoHS (M4 X 8)	60
-	4	4	4	4	2168400-4	SHCS, LOW HEAD, RoHS, M4 X 8	57
-	2	2	2	2	2168083-9	SCR, SKT HD CAP, RoHS, M4 X 20	56
-	2	2	2	2	5018030-2	NUT, HEX, REG, RoHS, M4	55
-	2	2	2	2	5018030-1	NUT, HEX, REG, RoHS, M3	54
-	2	2	2	2	986965-8	NUT, LOCK, HEX, TORQUE (M4)	53
-	-	-	-	1	2119792-1	PAWL, EF, AIR	51
-	-	-	-	1	18023-9	SCR, SKT HD CAP M4 X 6.0	49
-	1	1	1	1	2119655-5	APPLICATOR BASIC ASSEMBLY, EF	46
-	1	-	1	1	2119369-1	RAM, AMP STYLE, END FEED	44
-	1	1	1	1	2079383-7	SCR, BHSC, RoHS (M8 X 25)	41
-	1	-	1	1	2119645-1	DISC, NUMBERED FA WIRE ADJUSTMENT	40
-	1	-	1	1	2119957-1	APPLICATOR SHIM PACK	39
-	1	1	1	1	2119644-2	RAM WASHER, PRECISION	38
-	1	1	1	1	2119085-1	FA HEAD, ATLANTIC STYLE	37
-	1	-	1	1	2119092-1	BOLT, ADJUSTMENT	35
-	8	8	8	8	1-18028-2	WASHER, FLAT, REG M4	33
-	2	2	2	2	2168083-9	SCR, SKT HD CAP, RoHS, M4 X 20	31
-	2	2	2	2	1-2168083-0	SCR, SKT HD CAP, RoHS, M4 X 10	29
-	1	1	1	1	240639-1	STRIPPER (MACHINING)	27
-	2	2	2	2	1320906-1	STUD, THREADED	25
-	1	1	1	1	1752371-5	PLATE, STRIP GUIDE	24
-	2	2	2	2	2-22281-3	SPRING, COMPRESSION	22
-	1	1	1	1	1752373-1	DRAG	20
-	1	1	1	1	1-1901696-0	STRIP GUIDE, REAR	19
-	1	1	1	1	1-1901695-0	STRIP GUIDE, FRONT	18
-	4	4	4	4	1-2079383-1	SCR, BHSC, RoHS (M6 X 12)	17
-	1	1	1	1	1-240641-4	SPACER	16
-	1	1	1	1	240644-1	PLATE, REAR SHEAR	11
-	-	-	-	-	-	-	10
-	1	1	1	1	690482-5	PLATE, FRONT SHEAR	9
-	1	1	1	1	1803000-1	ANVIL, COMBINATION, END FEED	8
-	1	1	1	1	1-690474-6	BLADE, SLUG	7
-	1	1	1	1	2-240641-5	SPACER	5
-	1	1	1	1	238009-1	BLOCK, FL CRIMPER SPACER	4
-	1	1	1	1	3-2119582-4	CRIMPER, INSULATION F PREMIUM	3
-	1	1	1	1	455888-7	SPACER, CRIMPER	2
-	1	1	1	1	6-456406-5	CRIMPER, WIRE PREMIUM	1

DIMENSIONS:		TOLERANCES UNLESS OTHERWISE SPECIFIED:		MATERIAL:	
mm	0 PLC ±.5	1 PLC ±.5	2 PLC ±.13	3 PLC ±.013	4 PLC ±.0001
	ANGLES ±.0001	FINISH			

CHK	DATE	NAME	SIZE	CAGE CODE	DRAWING NO	RESTRICTED TO
C. CHEN	29DEC2011	S. XI	A1	00779	©=2150022	B

CUSTOMER ACCESSIBLE PRODUCTION DRAWING SCALE 1:1 SHEET 1 OF 4 REV B

ATLANTIC VERSION
 Shown on sheets 1 of 4 & 2 of 4
 (Pacific version shown on sheets 3 of 4 & 4 of 4)

LOC	DIST	REV	DATE	BY	APPV
A	66				

FEED TYPE

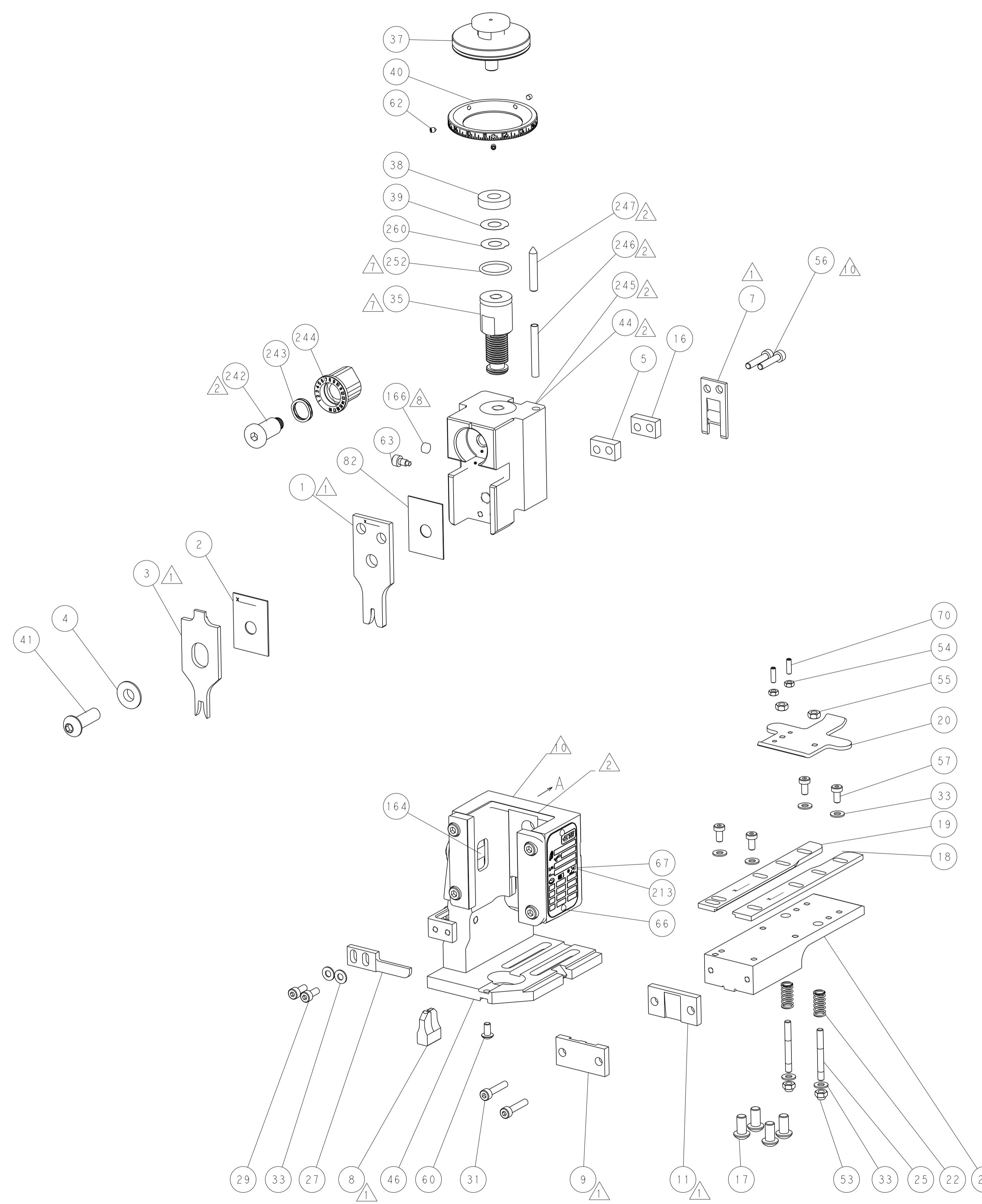

PNEUMATIC

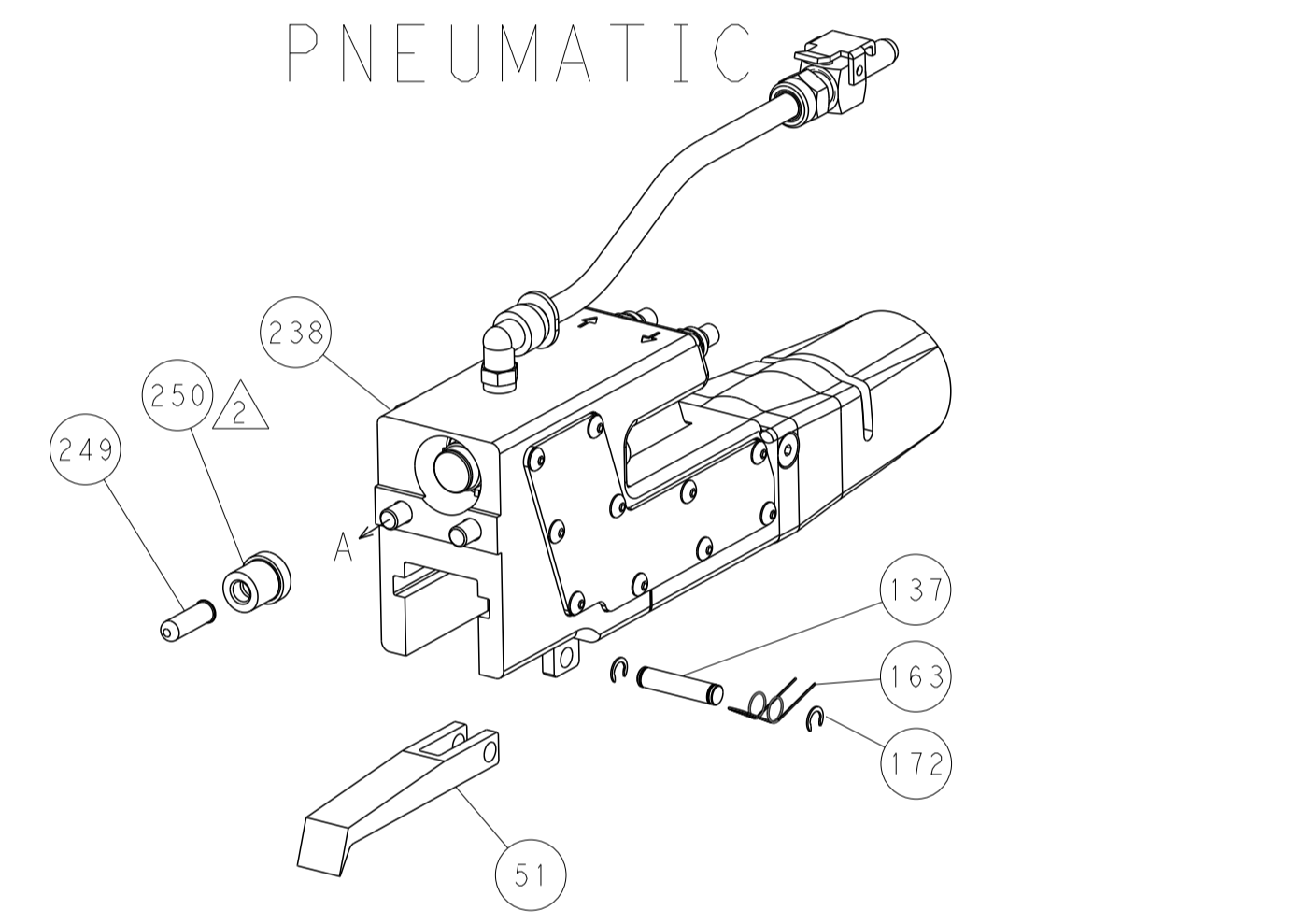

SERVO LATCH PLATE

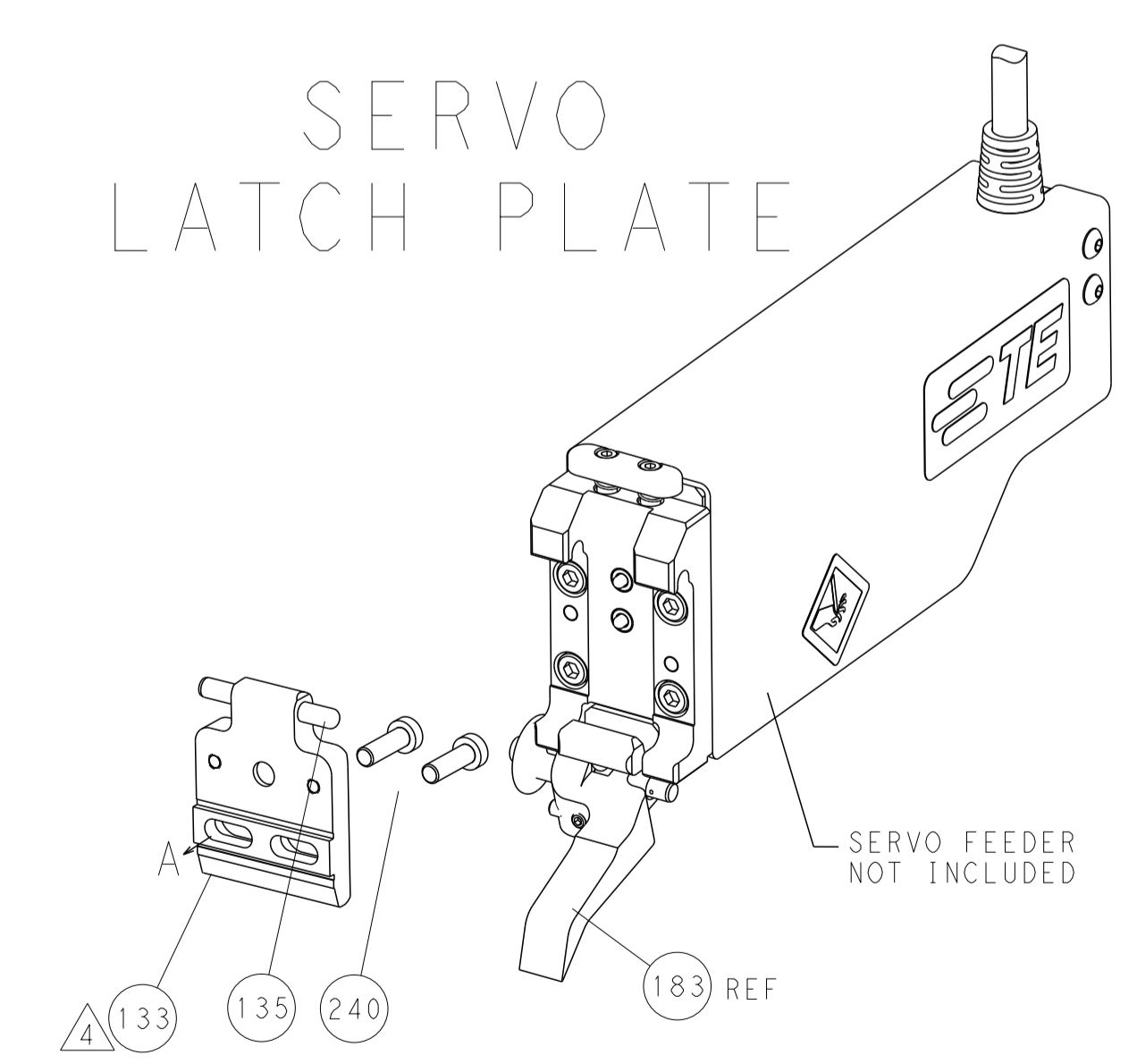

CAM POSITION

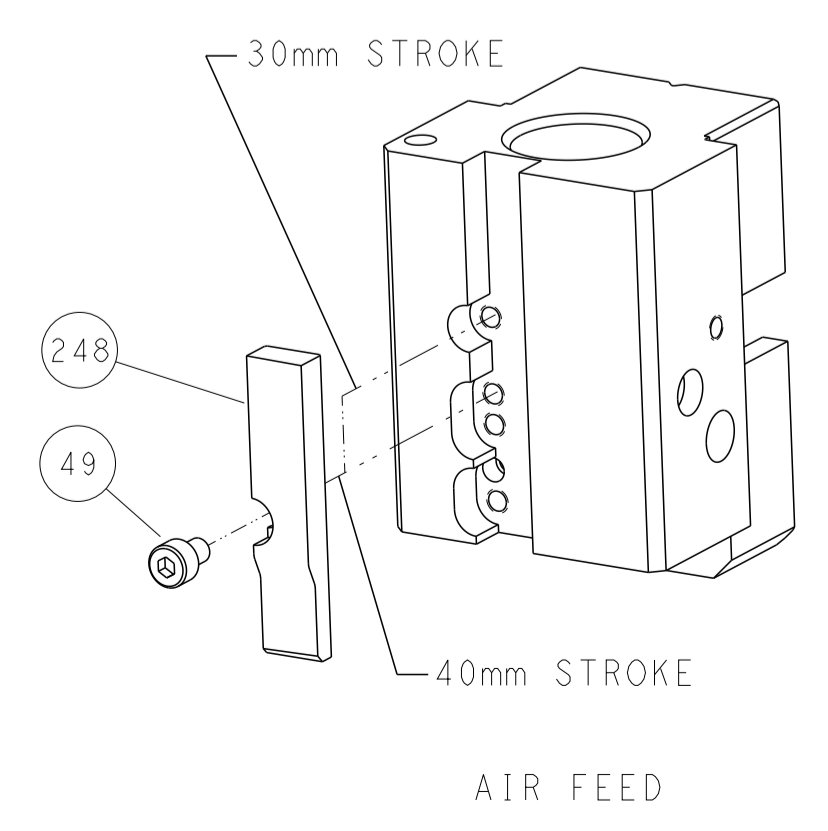

ATLANTIC VERSION
 Shown on sheets 1 of 4 & 2 of 4
 (Pacific version shown on sheets 3 of 4 & 4 of 4)

DIMENSIONS: mm 		TOLERANCES UNLESS OTHERWISE SPECIFIED: 0 PLC ±.5 1 PLC ±0.5 2 PLC ±0.13 3 PLC ±0.013 4 PLC ±0.001 ANGLES ±.0001 FINISH		DWN C. CHEN 29DEC2011 CHK S. XI 29DEC2011 APVD J. CRUZ 29DEC2011 NAME Ocean End Feed Applicator SIZE CAGE CODE DRAWING NO RESTRICTED TO A1 00779 C=2150022 CUSTOMER ACCESSIBLE PRODUCTION DRAWING SCALE 1:1 SHEET 2 OF 4 REV B	
MATERIAL:		WEIGHT:		DATE: 29DEC2011 BY: J. CRUZ APPV: J. CRUZ	

PACIFIC VERSION TERMINATOR INTERFACE ADAPTER	PART NUMBER	REVISION	DESCRIPTION	FEED TYPE	APPLICATOR STYLE CONVERSION CHART					
					CONVERT TO	PART NUMBERS REQUIRED				
	2-2150022-2	B	FINE CRIMP HEIGHT ADJUST	PNEUMATIC	-	-	-	-	-	-
					SERVO LATCH PLATE	2119951-1	1901697-1	8-2150022-5	-	2168400-7 (QUANTITY 2)
					SMART APPLICATOR	2161326-1	-	8-2150022-4	-	-
	2-2150022-5	B	FINE CRIMP HEIGHT ADJUST	SERVO LATCH PLATE Δ	-	-	-	-	-	-
2-2150022-7	B	FINE CRIMP HEIGHT ADJUST	NONE	-	-	-	-	-	-	
7-2150022-7	A	CRIMP TOOLING KIT	-	-	-	-	-	-	-	

APPLICATOR DATA		
CRIMP	SIZE	TYPE
WIRE	2.29 mm [.090]	F
INSUL	4.06 mm [1.60]	F
APPL INSTRUCTIONS 408-10390		

TERMINAL DATA: TE TERMINAL		TE CRIMP SPECIFICATION	
TERMINAL NAME: RING TONGUE			
WIRE STRIP LENGTH		INSULATION DIAMETER RANGE	
4.80-5.60 mm [1.89-.220 IN]		\varnothing 2.00-3.30 mm [1.079-.130 IN]	
TERMINAL APPLICATION SPECIFICATION	114-3118	-	-
TERMINALS APPLIED Δ			
TE TERMINAL	TE TERMINAL	TE TERMINAL	TE TERMINAL
880628-1	880628-2	880630-1	880630-2

WIRE SIZE	CRIMP HEIGHT mm [INCH]	CRIMP HEIGHT REFERENCE SETTING Δ
1.00mm2	1.98 +/- 0.05 [1.078 +/- .002]	12.7
0.75mm2	1.93 +/- 0.05 [1.076 +/- .002]	13.3
0.50mm2	1.88 +/- 0.05 [1.074 +/- .002]	13.9

- RECOMMENDED SPARE PARTS
- Δ GREASE BEARING SURFACES LIGHTLY
- 3. LUBRICATE DAILY PER THE APPLICATOR INSTRUCTION SHEET SUPPLIED WITH THE APPLICATOR.
- Δ APPLICATOR SPECIFIC DATA TO BE ENTERED INTO BLANK MEMORY CHIP AT ASSEMBLY. SEE BELOW FOR PART NUMBER:
 PNEUMATIC FEED WITH "SMART APPLICATOR" CONVERSION: 8-2150022-4
 SERVO FEED WITH "FINE CRIMP HEIGHT ADJUST": 8-2150022-5
- 5. ADJUSTMENT OF THE STRIPPER MAY BE REQUIRED WHEN MOVING THE APPLICATOR BETWEEN BENCH AND LEADMAKER APPLICATIONS.
- Δ APPLY PART NUMBER 1-23419-5 LOCTITE TO THREADS OF ITEMS 62.
 APPLY PART NUMBER 2-23419-6 LOCTITE TO THREADS OF ITEMS 242.
- Δ GREASE THREADS, GROOVE AND O-RING ON ITEMS 139 & 153.
- Δ MAGNET, ITEM 166 MUST BE ORIENTED CORRECTLY IN ORDER TO PROPERLY ACTUATE THE COUNTER.
- Δ CRIMP HEIGHT REFERENCE SETTING WAS THE SETTING USED WHEN THE APPLICATOR WAS QUALIFIED AT THE FACTORY. ADJUSTMENT MAY BE NECESSARY WHEN RUNNING APPLICATOR IN THE FIELD.
- Δ CUT TO LENGTH AT ASSEMBLY.
- Δ THE RECOMMENDED SET-UP FOR END FEED APPLICATORS IS POST-FEED WITH ITEM 2119653-1. THE APPLICATOR CAN BE CONFIGURED FOR PRE-FEED WITH ITEM 2119652-1 BUT MAY ENCOUNTER PROBLEMS WITH SOME APPLICATIONS. FEED ISSUES OR TERMINAL JAMMING MAY OCCUR IN THE PRE-FEED CONFIGURATION.
- Δ TERMINAL PITCH NOT COMPATIBLE WITH MECHANICAL FEED.

***WARNING**
 ON INSTALLATION, SET WIRE DISC, ITEM 40 TO LARGEST WIRE SIZE SETTING. USE OF SETTINGS BELOW MINIMUM REQUIRED CRIMP HEIGHT SETTING WILL CAUSE DAMAGE TO CRIMP TOOLING.

PACIFIC VERSION
 Shown on sheets 3 of 4 & 4 of 4
 (Atlantic version shown on sheets 1 of 4 & 2 of 4)

SET UP GAUGE	LOC	DIST	REVISIONS			
2119599-2	A	66	REV	DATE	BY	APPD
-	-	-	SEE SHEET 1	-	-	-

-	1	1	1	2119782-1	FINE ADJUST HEAD ASM, PACIFIC STYLE	251
-	-	-	1	2119640-1	PUSH ROD, AIR FEED	250
-	-	-	1	2079988-1	BUSHING, LCH5-12, MISUMI	249
-	1	1	1	1-22279-3	SPRING, COMPRESSION	246
-	1	1	1	2119082-9	CAM, SNAIL, INSULATION ADJUSTMENT	244
-	1	1	1	2079764-1	WASHER, WAVE SPRING, CREST-TO-CREST	243
-	1	1	1	2119083-1	RETAINER, INSULATION DIAL	242
-	-	2	-	2168400-7	SHCS, LOW HEAD, RoHS, M5 X 10	240
-	-	-	1	2063440-2	AIR FEED MODULE	238
-	-	1	-	2119740-2	TAG, IDENTIFICATION	213
-	4	4	4	2079383-9	SCR, BHSC, RoHS (M6 X 20)	186
-	-	REF	-	1901697-1	FEED FINGER ASSEMBLY, EF	183
-	-	-	2	21045-3	RING, RETAIN, EXTERN, 3/16 CRESCENT	172
-	1	1	1	994969-1	MAGNET, RARE EARTH HIGH ENERGY	166
-	REF	REF	REF	994970-2	COUNTER, MAGNETIC	164
-	-	-	1	240638-1	SPRING, FEED FINGER	163
-	1	1	1	8-21084-1	O-RING, .801 ID, .070 DIA. MAT.	153
-	-	-	1	2119641-2	FEED CAM, AIR FEED	152
-	1	1	1	2119798-2	DETENT PIN	145
-	1	1	1	2079383-8	SCR, BHSC, RoHS (M4 X 16)	144
-	1	1	1	2119655-6	APPLICATOR BASIC ASSEMBLY, EF	141
-	1	1	1	2119651-1	RAM, ASIAN STYLE, END FEED	140
-	1	1	1	2119092-2	BOLT, ADJUSTMENT	139
-	-	-	1	3-23627-7	PIN, RETAIN, GRVD, 3/16 X .854	137
-	-	REF	-	SEE NOTE 4	MEMORY CHIP, PROGRAMMED	135
-	-	1	-	1633743-1	SERVO FEED LATCH ASM	133
-	1	1	1	455888-5	SPACER, CRIMPER	82
-	1	1	1	2119956-2	DOCUMENTATION PACKAGE	71
-	2	2	2	2-18032-2	SCR, SET, FLT POINT M3 X 10.0	70
-	1	-	1	2119740-1	TAG, IDENTIFICATION	67
-	2	2	2	2168078-1	SCREW, DRIVE, RH, RoHS, 2 x .188	66
-	1	1	1	2119793-1	LIMITER, ADJUSTMENT BOLT	63
-	3	3	3	992763-5	SCR, SET, SOC, CONE POINT, M3 X 4.0	62
-	4	4	4	2168400-4	SHCS, LOW HEAD, RoHS, M4 X 8	57
-	2	2	2	2168083-9	SCR, SKT HD CAP, RoHS, M4 X 20	56
-	2	2	2	5018030-2	NUT, HEX, REG, RoHS, M4	55
-	2	2	2	5018030-1	NUT, HEX, REG, RoHS, M3	54
-	2	2	2	986965-8	NUT, LOCK, HEX, TORQUE (M4)	53
-	-	-	1	2119792-1	PAWL, EF, AIR	51
-	-	-	1	18023-9	SCR, SKT HD CAP M4 X 6.0	49
-	1	1	1	2079383-7	SCR, BHSC, RoHS (M8 X 25)	41
-	1	1	1	2119645-1	DISC, NUMBERED FA WIRE ADJUSTMENT	40
-	1	1	1	2119957-1	APPLICATOR SHIM PACK	39
-	1	1	1	2119644-2	RAM WASHER, PRECISION	38
-	8	8	8	1-18028-2	WASHER, FLAT, REG M4	33
-	2	2	2	2168083-9	SCR, SKT HD CAP, RoHS, M4 X 20	31
-	2	2	2	1-2168083-0	SCR, SKT HD CAP, RoHS, M4 X 10	29
-	1	1	1	240639-1	STRIPPER (MACHINING)	27
-	2	2	2	1320906-1	STUD, THREADED	25
-	1	1	1	1752371-5	PLATE, STRIP GUIDE	24
-	2	2	2	2-22281-3	SPRING, COMPRESSION	22
-	1	1	1	1752373-1	DRAG	20
-	1	1	1	1-1901696-0	STRIP GUIDE, REAR	19
-	1	1	1	1-1901695-0	STRIP GUIDE, FRONT	18
-	1	1	1	1-240641-4	SPACER	16
-	1	1	1	240644-1	PLATE, REAR SHEAR	11
-	-	-	-	-	-	10
-	1	1	1	690482-5	PLATE, FRONT SHEAR	9
-	1	1	1	1803000-1	ANVIL, COMBINATION, END FEED	8
-	1	1	1	1-690474-6	BLADE, SLUG	7
-	1	1	1	2-240641-5	SPACER	5
-	1	1	1	238009-1	BLOCK, FL CRIMPER SPACER	4
-	1	1	1	3-2119582-4	CRIMPER, INSULATION F PREMIUM	3
-	1	1	1	455888-7	SPACER, CRIMPER	2
-	1	1	1	6-456406-5	CRIMPER, WIRE PREMIUM	1

DIMENSIONS:		TOLERANCES UNLESS OTHERWISE SPECIFIED:		MATERIAL:		FINISH:		WEIGHT:		CUSTOMER ACCESSIBLE PRODUCTION DRAWING	
mm	0 PLC ±.5	1 PLC ±0.5	2 PLC ±0.13	3 PLC ±0.013	4 PLC ±0.001	ANGLES ±.0001	FINISH				
APPLICATOR DATA		APPLICATOR DATA		APPLICATOR DATA		APPLICATOR DATA		APPLICATOR DATA		APPLICATOR DATA	
APPLICATOR DATA		APPLICATOR DATA		APPLICATOR DATA		APPLICATOR DATA		APPLICATOR DATA		APPLICATOR DATA	

LOC	DIST	REVISIONS			
P	LTN	DESCRIPTION	DATE	DMN	APVD
A	66	SEE SHEET 1	-	-	-

FEED TYPE

PNEUMATIC

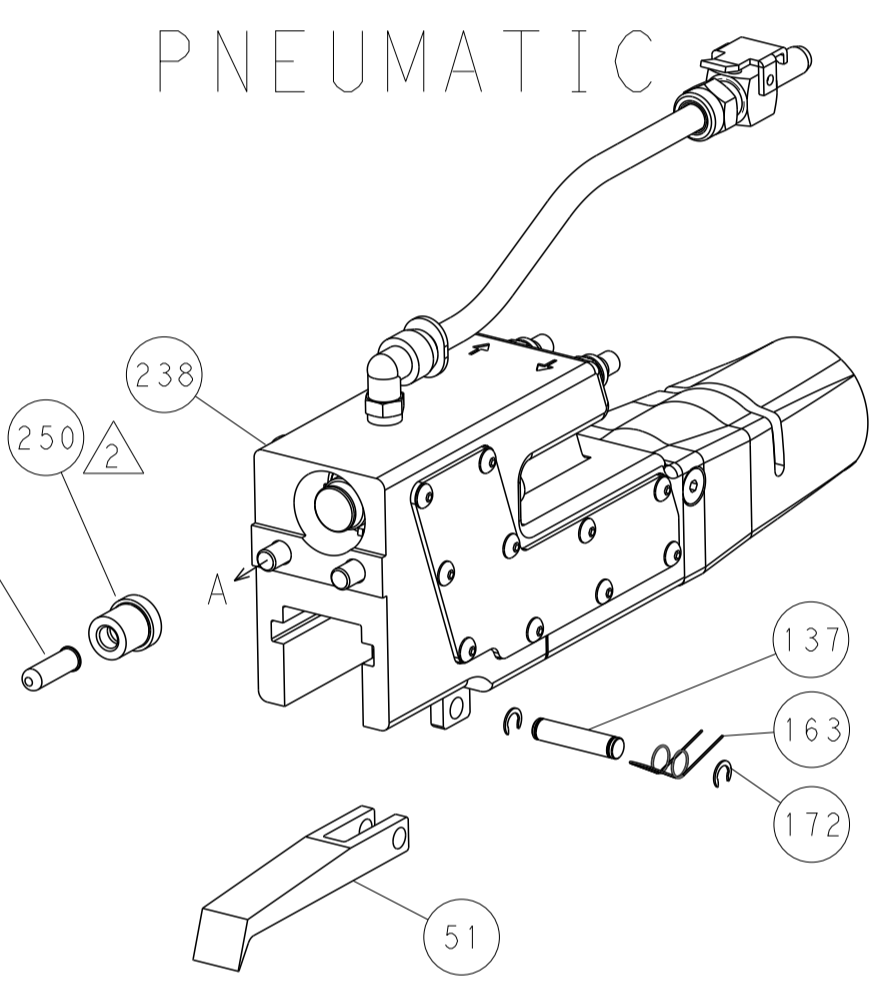

SERVO LATCH PLATE

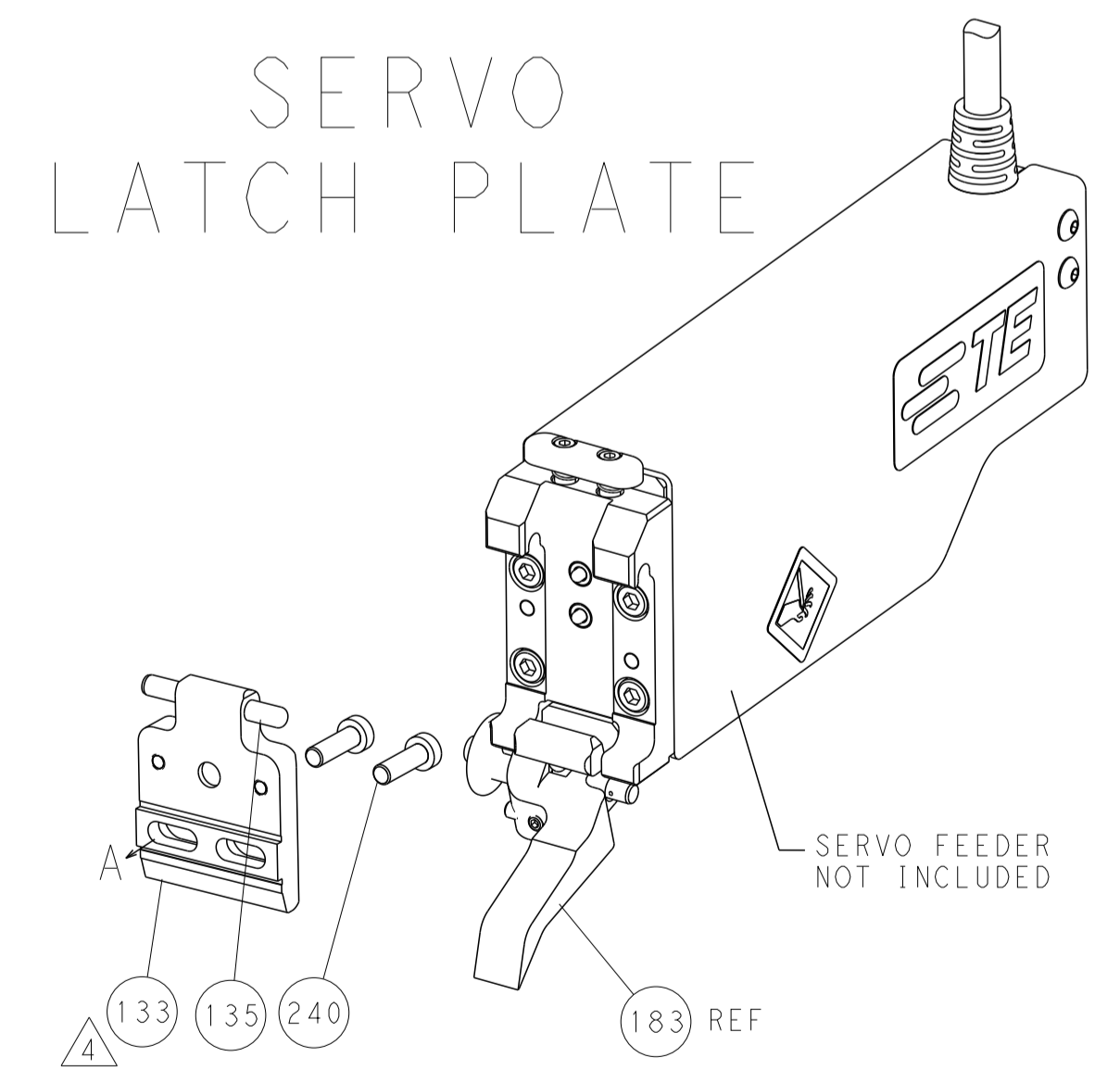

CAM POSITION

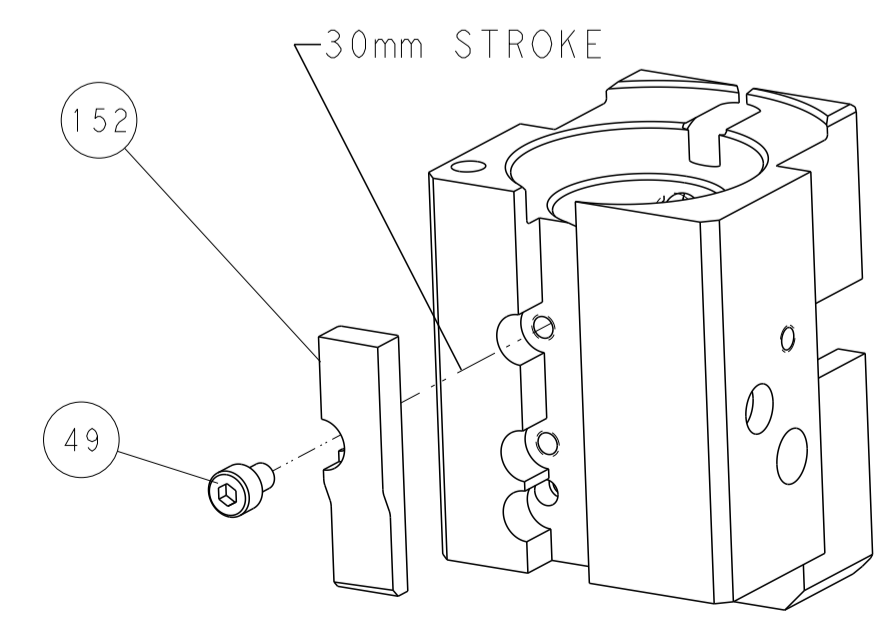

AIR FEED

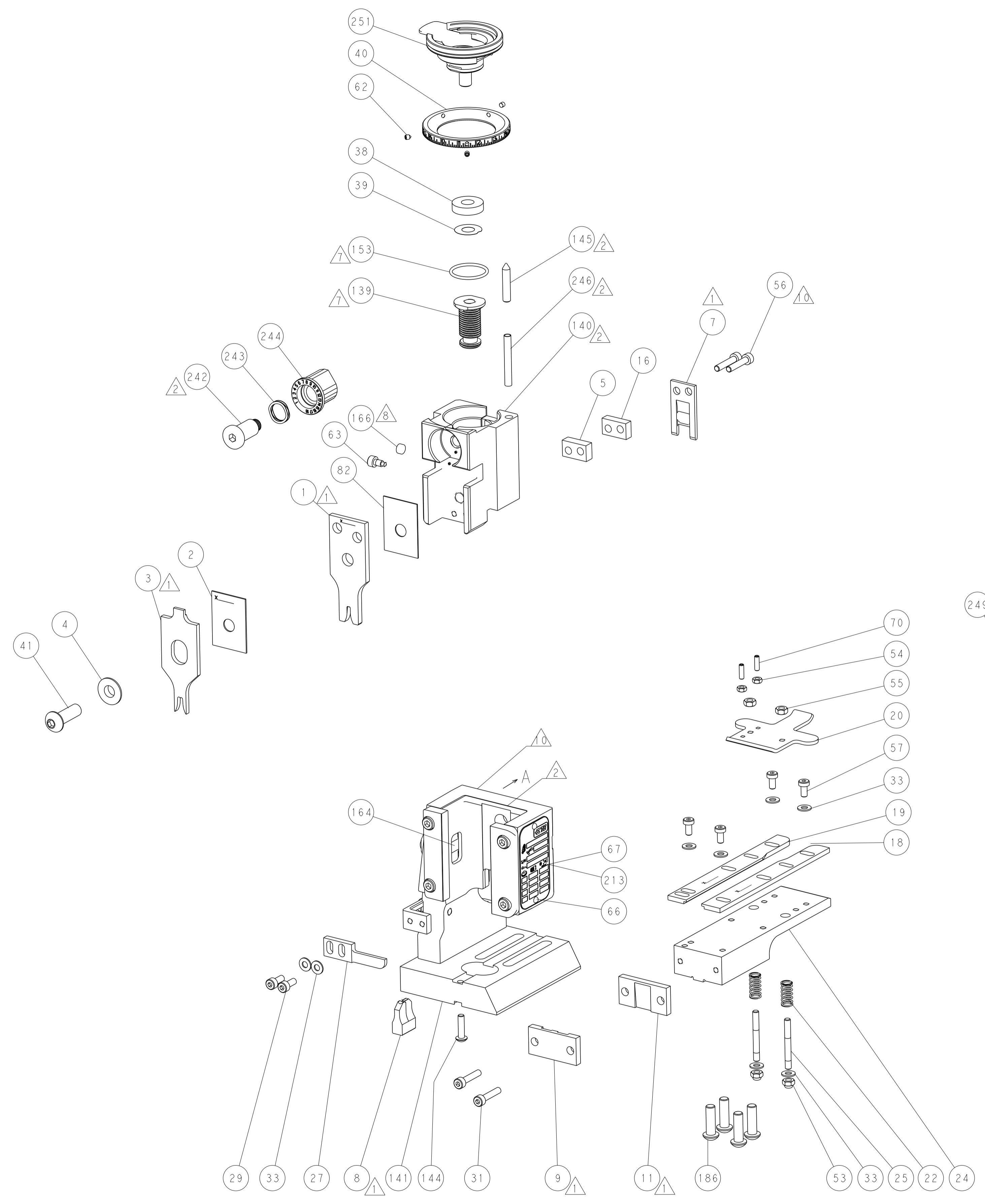

PACIFIC VERSION
 Shown on sheets 3 of 4 & 4 of 4
 (Atlantic version shown on sheets 1 of 4 & 2 of 4)

<small>THIS DRAWING IS UNPUBLISHED. RELEASED FOR PUBLICATION 20. COPYRIGHT 20 BY TYCO ELECTRONICS CORPORATION. ALL RIGHTS RESERVED.</small>		DWN: C. CHEN 29DEC2011 CHK: S. XI 29DEC2011 APVD: J. CRUZ 29DEC2011	TE Connectivity Harrisburg, PA 17105-3608
DIMENSIONS: mm TOLERANCES UNLESS OTHERWISE SPECIFIED: 0 PLC ±.5 1 PLC ±.5 2 PLC ±.13 3 PLC ±.013 4 PLC ±.0001 ANGLES FINISH ±.		NAME: Ocean End Feed Applicator PRODUCT SPEC: - APPLICATION SPEC: - WEIGHT: - CUSTOMER ACCESSIBLE PRODUCTION DRAWING	SIZE: A1 CAGE CODE: 00779 DRAWING NO: C=2150022 SCALE: 1:1 SHEET: 4 of 4 REV: B