

## Top view LEDs 67-23/R6GHBHC-B05/2T



### Features

- P-LCC-4 package.
- Optical indicator.
- Colorless clear window.
- Pb-free.
- The product itself will remain within RoHS compliant version.

### Applications

- Telecommunication: indicator and backlighting in telephone and fax.
- Flat backlight for LCD's, switches and symbols.
- Light pipe application.
- General use.

## Device Selection Guide

Chip Materials	Emitted Color		Resin Color
R6	AlGaInP	Brilliant Red	Water clear
GH	InGaN	Brilliant Green	
BH	InGaN	Blue	

## Absolute Maximum Ratings (Ta=25°C)

Parameter	Symbol	Rating	Unit
Reverse Voltage	$V_R$	5	V
Forward Current	$I_F$	R6	25
		GH	25
		BH	25
Peak Forward Current	IFP	R6	100
		GH	100
		BH	100
Power Dissipation	Pd	R6	120
		GH	110
		BH	110
Operating Temperature	$T_{opr}$	-40 ~ +85	°C
Storage Temperature	$T_{stg}$	-40 ~ +90	°C
Soldering Temperature	$T_{sol}$	Reflow Soldering : 260 °C for 10 sec.	
		Hand Soldering : 350 °C for 3 sec.	

**Electro-Optical Characteristics (Ta=25°C)**

Parameter	Symbol	Min.	Typ.	Max.	Unit	Condition	
Luminous Intensity	I <sub>v</sub>	R6	112	-----	285	mcd	
		GH	180	-----	715		
		BH	72	-----	180		
Viewing Angle	2θ1/2	-----	120	-----	deg	I <sub>F</sub> =20mA	
Peak Wavelength	λ <sub>p</sub>	R6	-----	632	-----		nm
		GH	-----	518	-----		
		BH	-----	468	-----		
Dominant Wavelength	λ <sub>d</sub>	R6	621	-----	631		nm
		GH	520	-----	530		
		BH	465	-----	475		
Spectrum Radiation Bandwidth	Δλ	R6	-----	20	-----		nm
		GH	-----	35	-----		
		BH	-----	35	-----		
Forward Voltage	V <sub>F</sub>	R6	-----	2.0	2.4	V	
		GH	-----	3.4	3.95		
		BH	-----	3.4	3.95		
Reverse Current	I <sub>R</sub>	R6	-----	-----	10	μA	
		GH	-----	-----	50		
		BH	-----	-----	50		

Note:

1. Tolerance of Luminous Intensity: ±11%
2. Tolerance of Dominant Wavelength: ±1nm
3. Tolerance of Forward Voltage: ±0.1V

**Bin Range of Luminous Intensity**

Chip	Bin	Min	Max	Unit	Condition
R6	R	112	180	mcd	I <sub>F</sub> =20mA
	S	180	285		
GH	S	180	285		
	T	285	450		
	U	450	715		
BH	Q	72	112		
	R	112	180		

**Bin Range of Dominant Wavelength**

Chip	Bin	Min	Max	Unit	Condition
R6	FF1	621	626	nm	I <sub>F</sub> =20mA
	FF2	626	631		
GH	X	520	525		
	Y	525	530		
BH	X	465	470		
	Y	470	475		

1. Tolerance of Luminous Intensity: ±11%
2. Tolerance of Dominant Wavelength: ±1nm
3. Tolerance of Forward Voltage: ±0.1V

### Typical Electro-Optical Characteristics Curves (R6)

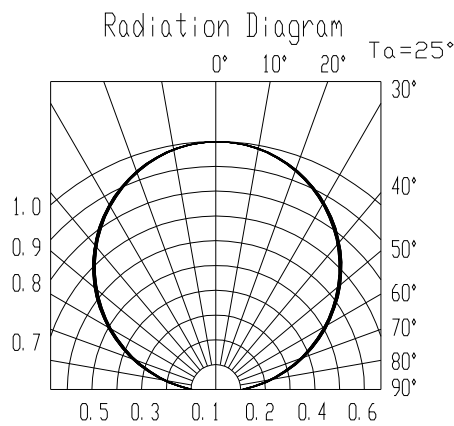
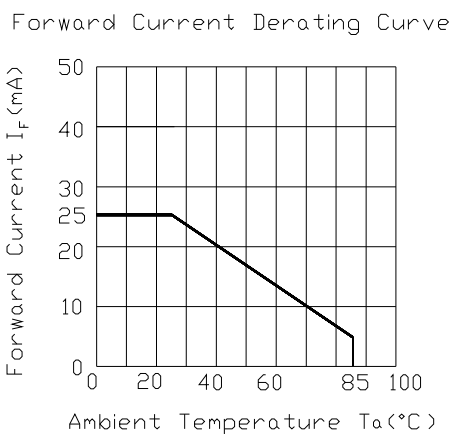
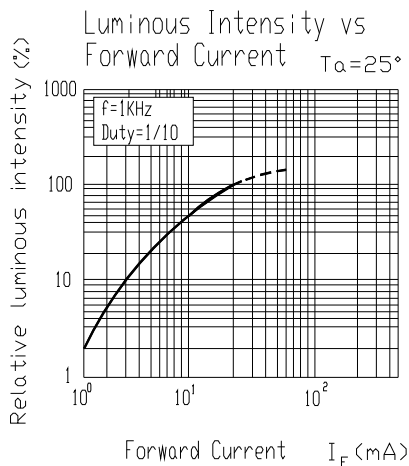
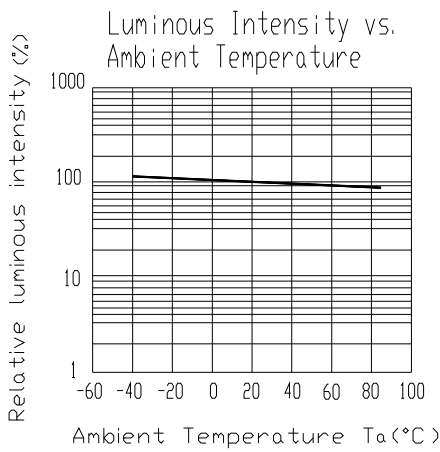
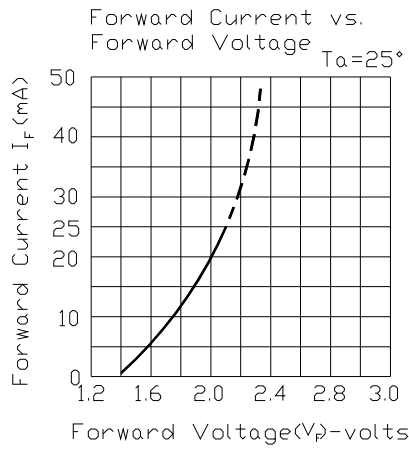
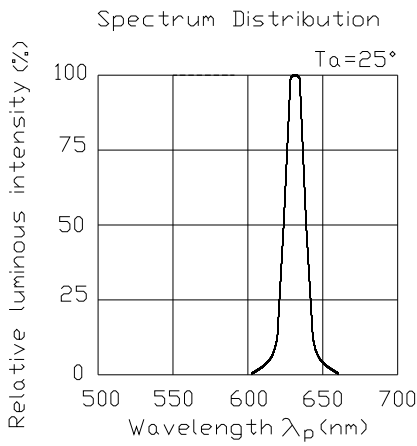

### Typical Electro-Optical Characteristics Curves (GH)

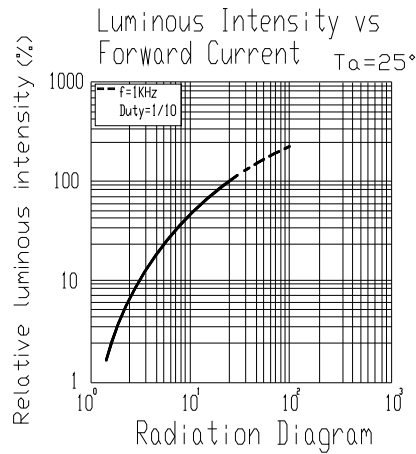
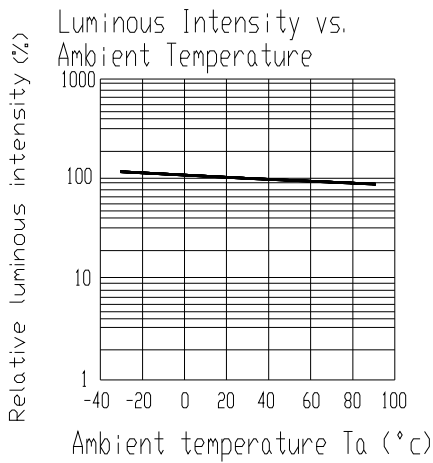
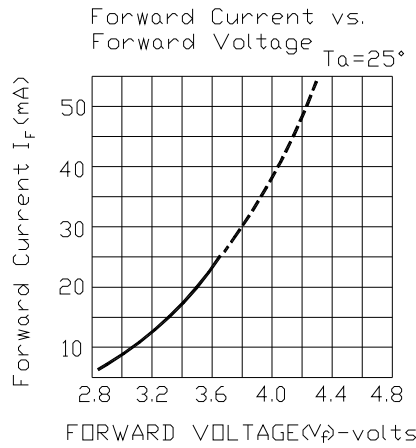
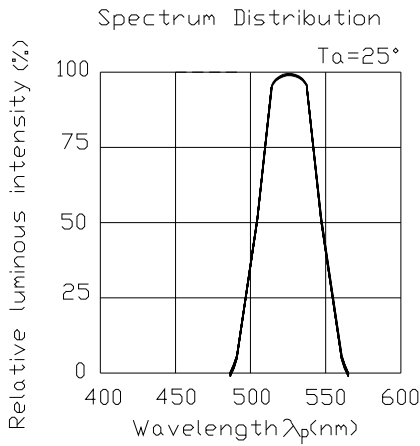

Forward Current Derating Curve

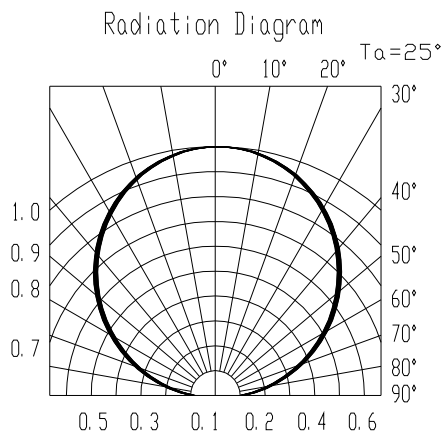
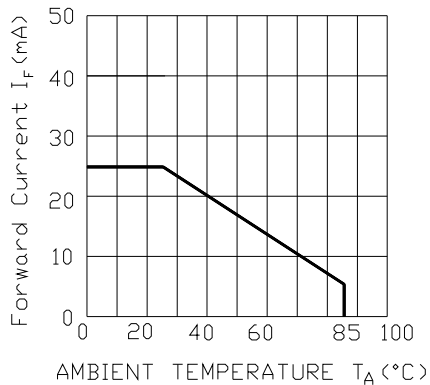

### Typical Electro-Optical Characteristics Curves (BH)

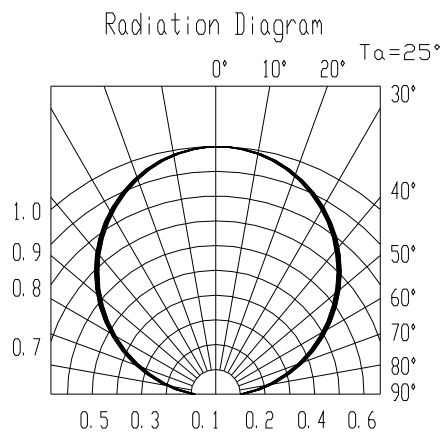
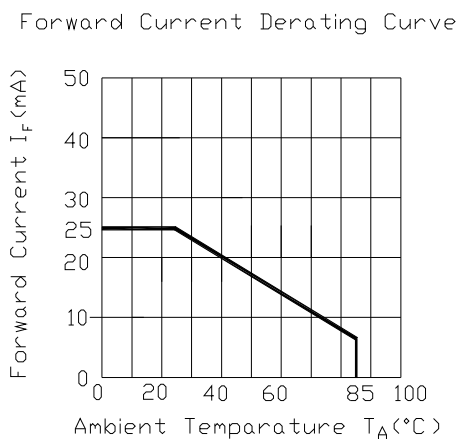
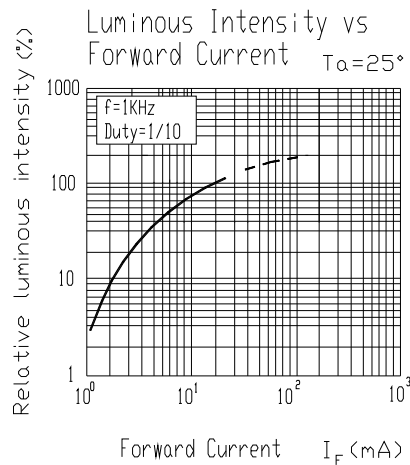
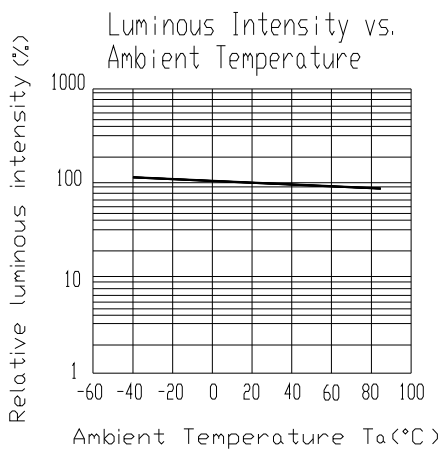
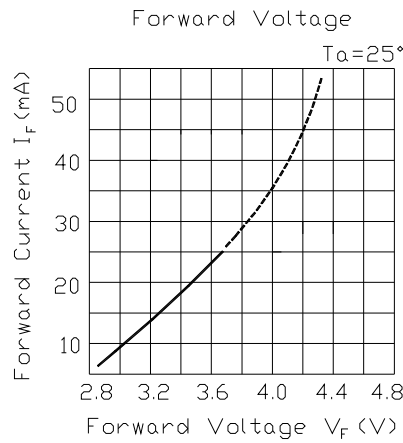
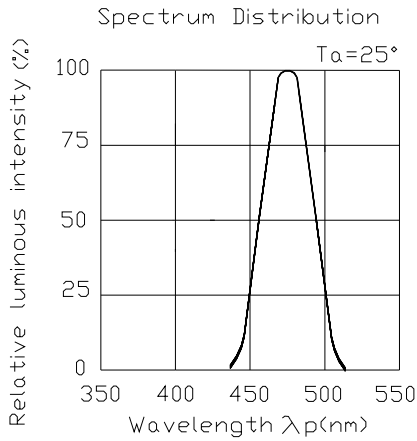

Package Dimension

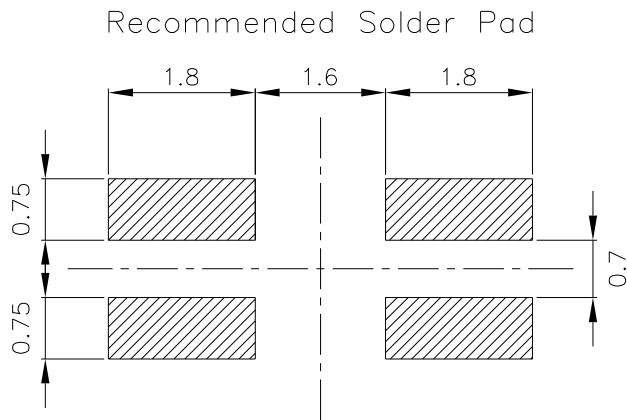
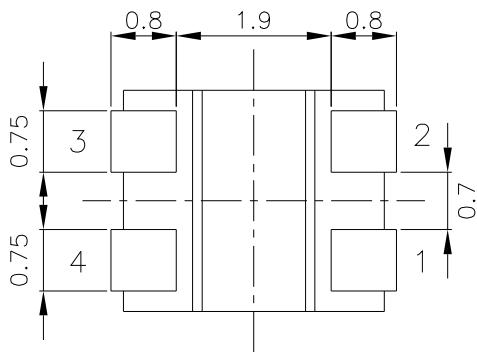
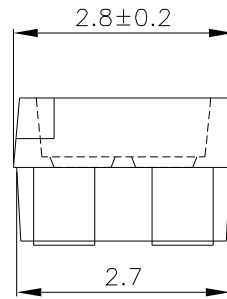
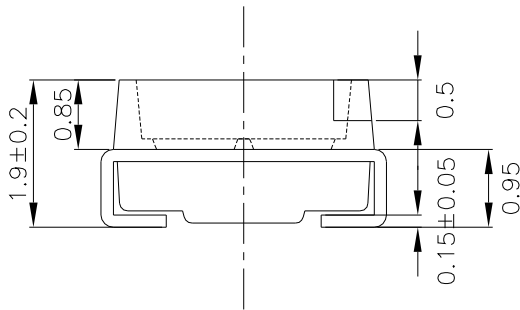
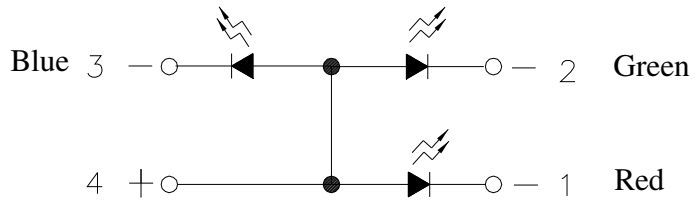
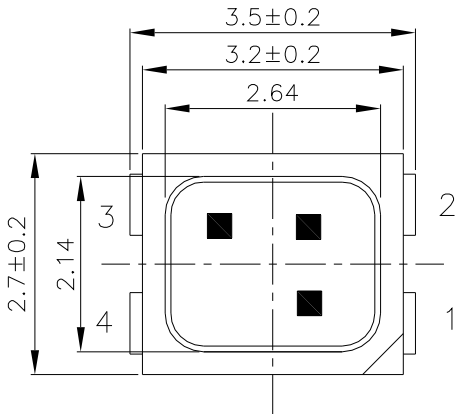

Note: Tolerances unless mentioned ±0.1mm. Unit = mm



**Moisture Resistant Packing Materials**

**Label Explanation**



- CPN: Customer's Product Number
- P/N: Product Number
- QTY: Packing Quantity
- CAT: Luminous Intensity Rank
- HUE: Dom. Wavelength Rank
- REF: Forward Voltage Rank
- LOT No: Lot Number

**Reel Dimensions**

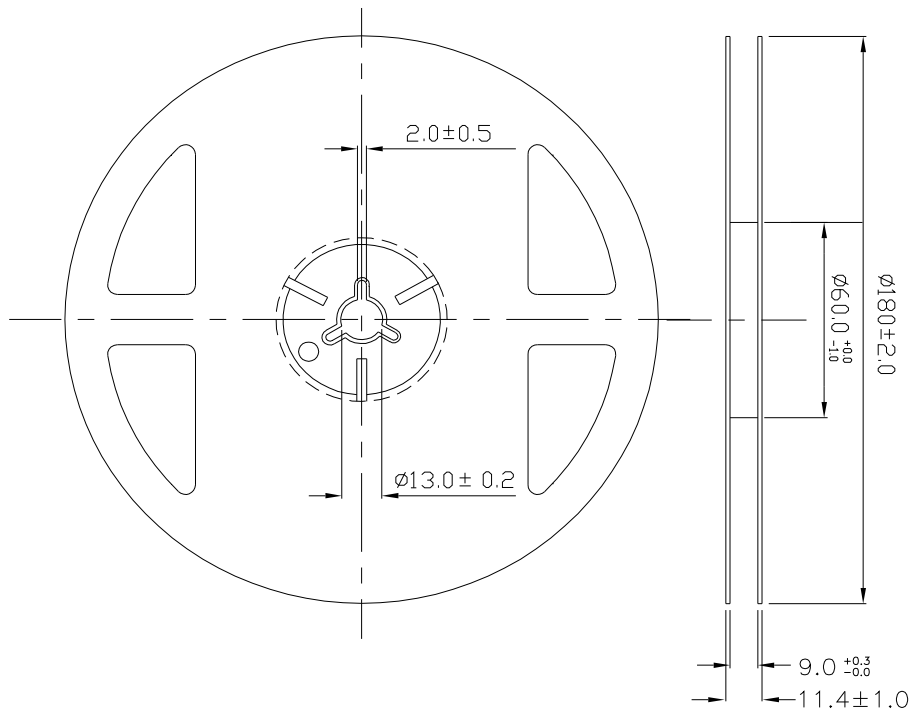

**Carrier Tape Dimensions: Loaded Quantity 2000 pcs Per Reel**

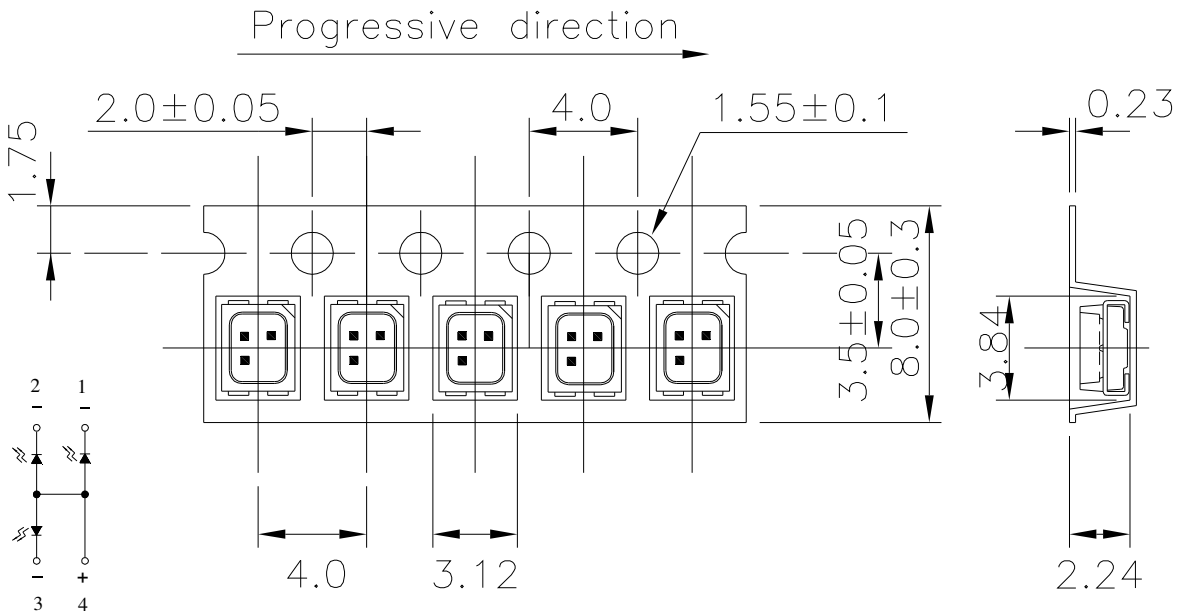

Note: Tolerances unless mentioned  $\pm 0.1$ mm. Unit = mm

**Moisture Resistant Packing Process**

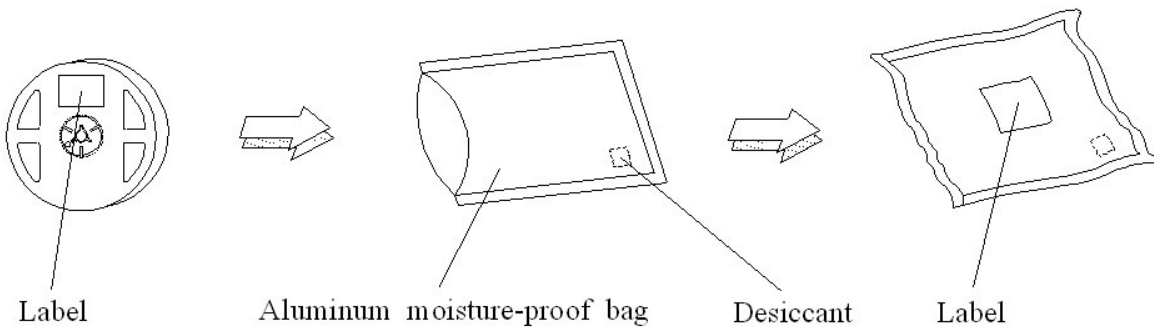

Note: Tolerances unless mentioned  $\pm 0.1$ mm. Unit = mm

## Precautions for Use

### 1. Over-current-proof

Customer must apply resistors for protection , otherwise slight voltage shift will cause big current change ( Burn out will happen ).

### 2. Storage

2.1 Do not open moisture proof bag before the products are ready to use.

2.2 Before opening the package, the LEDs should be kept at 30°C or less and 90%RH or less.

2.3 After opening the package: The LED's floor life are 168 hours under 30°C or less and 60% RH or less.

If unused LEDs remain, it should be stored in moisture proof packages.

2.4 If the moisture absorbent material (silica gel) has faded away or the LEDs have exceeded the storage time, baking treatment should be performed using the following conditions.

Baking treatment : 60±5°C for 24 hours.

### 3. Soldering Condition

#### 3.1 Pb-free solder temperature profile

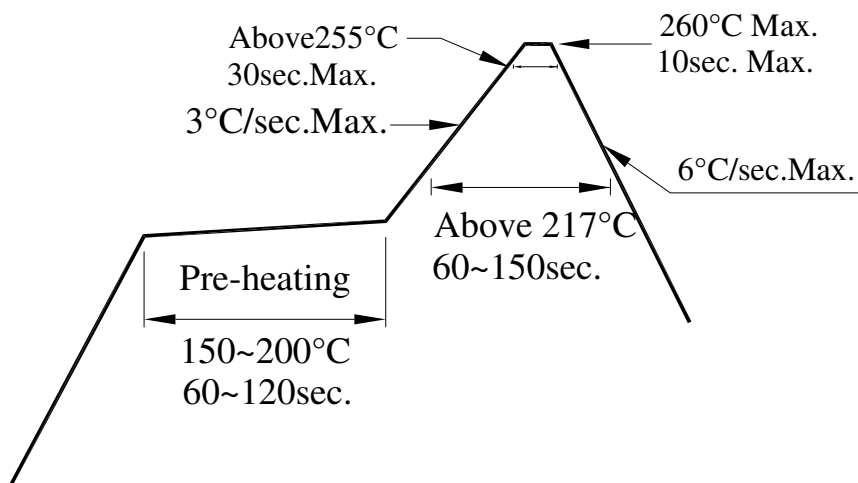

3.2 Reflow soldering should not be done more than two times.

3.3 When soldering, do not put stress on the LEDs during heating.

3.4 After soldering, do not warp the circuit board.

### 4. Soldering Iron

Each terminal is to go to the tip of soldering iron temperature less than 350°C for 3 seconds within once in less than the soldering iron capacity 25W. Leave two seconds and more intervals, and do soldering of each terminal. Be careful because the damage of the product is often started at the time of the hand solder.

### 5. Repairing

Repair should not be done after the LEDs have been soldered. When repairing is unavoidable, a double-head soldering iron should be used (as below figure). It should be confirmed beforehand whether the characteristics of the LEDs will or will not be damaged by repairing.

