

# Customer Information Sheet

DRAWING No.: M80-941XXXX SHEET 2 OF 2

IF IN DOUBT - ASK

©

NOT TO SCALE

THIRD ANGLE PROJECTION

ALL DIMENSIONS IN mm

ORDER CODE:

**M80-941XXXX**

TOTAL No. OF CONTACTS  
06, 08, 10, 12, 14,  
20, 26, 34, 42, 50

FINISH  
05 - GOLD CLIP, GOLD SHELL  
42 - GOLD CLIP, 100% TIN SHELL

**SPECIFICATIONS:**

**MATERIAL:**  
CABLE HOOD = 30% GLASS-FILLED POLYAMIDE 46  
DATAMATE MOULDING = 30% GLASS-FILLED PPS,  
UL94V-0, BLACK  
CONTACT CLIP = BERYLLIUM COPPER  
CONTACT SHELL = BRASS  
JACKSCREW = STAINLESS STEEL  
CABLE HOOD FIXING SCREW = MILD STEEL

**FINISH:**  
05 = 0.3µm GOLD CLIP, 0.25-0.3µm GOLD SHELL  
42 = 0.3µm GOLD CLIP, 3.5-5.0µm 100% TIN  
OVER NICKEL SHELL

CABLE HOOD FIXING SCREW = CHEMI-BLACK

**ELECTRICAL:**  
CURRENT RATING AT 25°C = 3.0A MAX  
CURRENT RATING AT 85°C = 2.2A MAX  
WORKING VOLTAGE = 800V AC/DC  
VOLTAGE PROOF = 1200V AC/DC  
CONTACT RESISTANCE = 25mΩ MAX  
INSULATION RESISTANCE = 100MΩ MIN

**MECHANICAL:**  
DURABILITY = 500 OPERATIONS

**ENVIRONMENTAL:**  
TEMPERATURE RANGE = -55°C TO +125°C

**PACKING:**  
BAG

FOR COMPLETE SPECIFICATION, SEE COMPONENT SPECIFICATION C005XX (LATEST ISSUE)

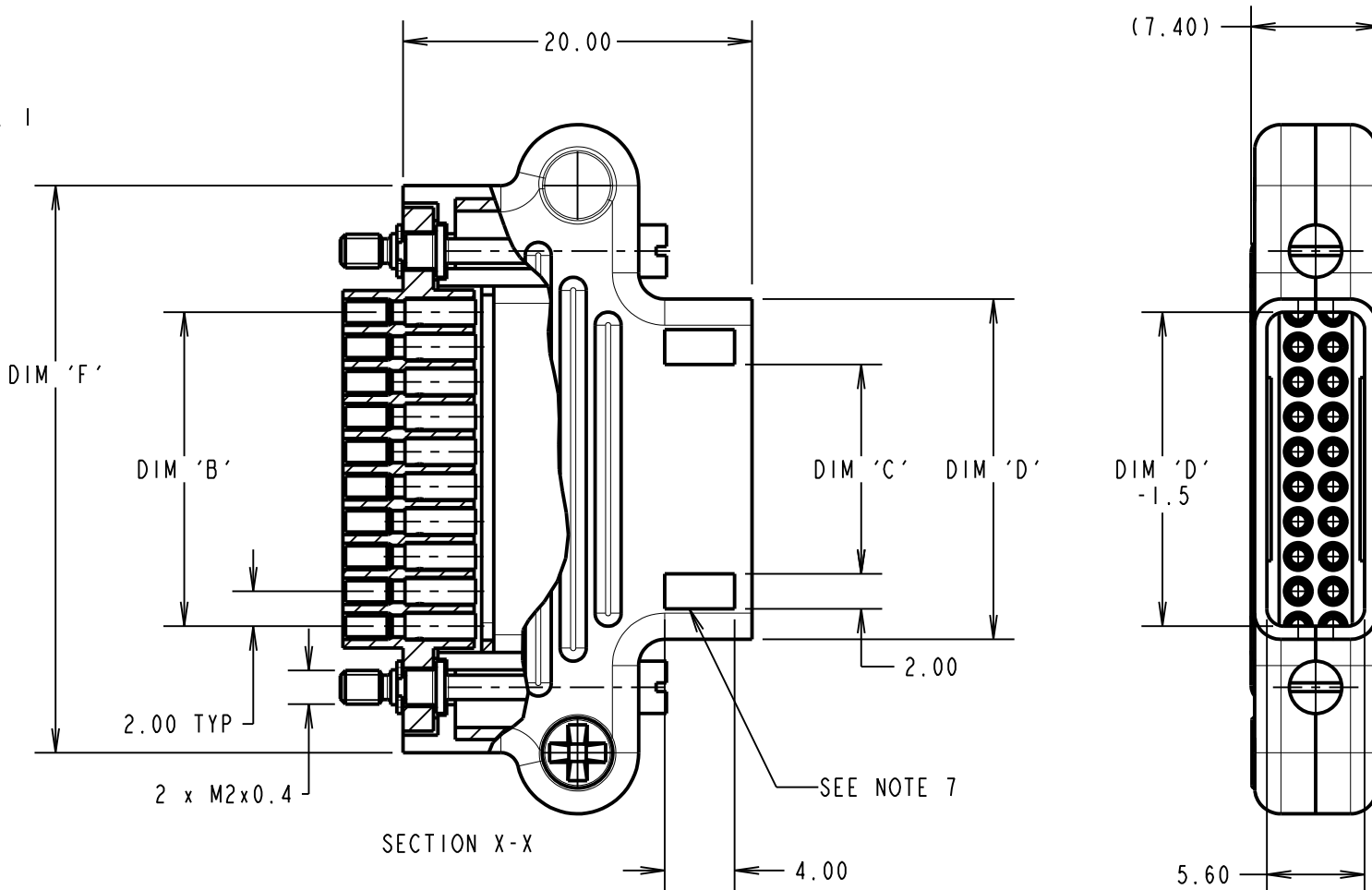
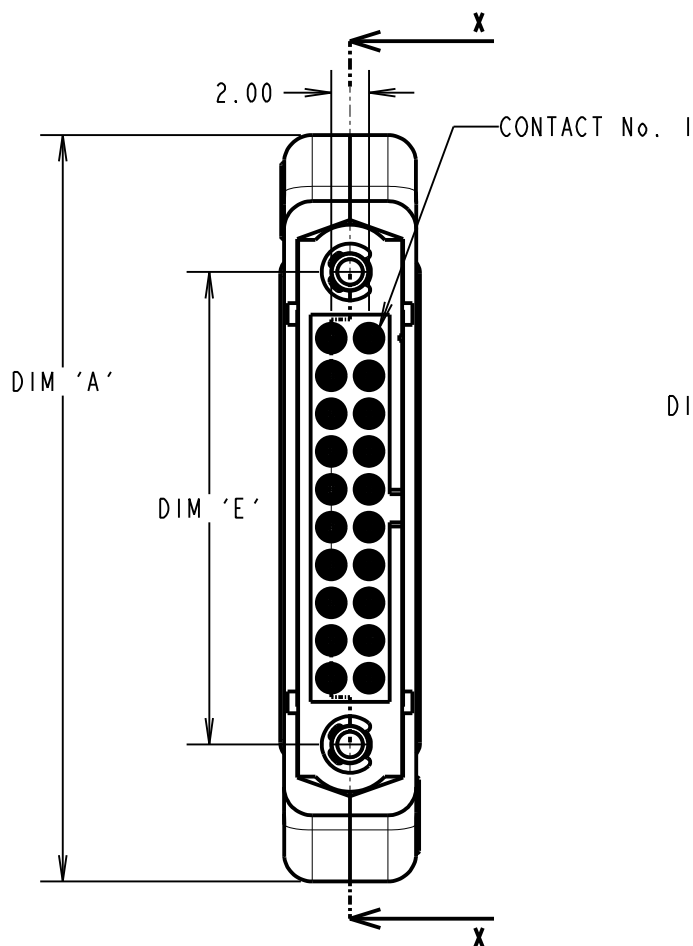

**NOTES:**

- CONNECTORS ARE SUPPLIED WITH CONTACTS, CABLE HOOD SET, AND CABLE HOOD FIXING SCREWS LOOSE.
- FOR EXTRA CONTACTS, USE PART NUMBER M80-01100XX (XX = 05 FOR GOLD FINISH, 01 FOR TIN FINISH).
- RECOMMENDED WIRE TYPE = BS 3G 210 TYPE A, PTFE INSULATED 22 AWG. MAX INSULATION DIAMETER = Ø1.10mm, STRIP WIRE BY 2.00mm.
- RECOMMENDED HAND CRIMP TOOL = M22520/2-01 WITH POSITIONER T5747. REFER TO TOOLING INSTRUCTION SHEET IS-01 FOR COMPLETE CRIMPING INSTRUCTIONS.
- CONTACT INSERTION AND EXTRACTION TOOL = Z80-280. REFER TO TOOLING INSTRUCTION SHEET IS-25 FOR ASSEMBLY INSTRUCTIONS.
- NO CABLE TIE SLOTS ON M80-94106XX AND M80-94108XX.

PART NUMBER	No. OF CONTACTS	PART DIMENSIONS					
		DIM 'A'	DIM 'B'	DIM 'C'	DIM 'D'	DIM 'E'	DIM 'F'
M80-94106XX	6	25.50	4.00	N/A	5.50	11.00	18.50
M80-94108XX	8	27.50	6.00	N/A	7.50	13.00	20.50
M80-94110XX	10	29.50	8.00	2.00	9.50	15.00	22.50
M80-94112XX	12	31.50	10.00	4.00	11.50	17.00	24.50
M80-94114XX	14	33.50	12.00	6.00	13.50	19.00	26.50
M80-94120XX	20	39.50	18.00	12.00	19.50	25.00	32.50
M80-94126XX	26	45.50	24.00	18.00	22.50	31.00	38.50
M80-94134XX	34	53.50	32.00	26.00	33.50	39.00	46.50
M80-94142XX	42	61.50	40.00	34.00	41.50	47.00	54.50
M80-94150XX	50	69.50	48.00	42.00	49.50	55.00	62.50

FM	7	26.03.18	20940
NAME	ISS.	DATE	C/NOTE
APPROVED: F. MCGOWAN			
CHECKED: S. BENNETT			
DRAWN: N. CODLING			
CUSTOMER REF.:			
ASSEMBLY DRG:			

**HARWIN**

www.harwin.com  
technical@harwin.com

THIS DRAWING AND ANY INFORMATION OR DESCRIPTIVE MATTER SET OUT HEREON ARE CONFIDENTIAL AND COPYRIGHT PROPERTY OF THE HARWIN GROUP AND MUST NOT BE DISCLOSED, LOANED, COPIED OR USED FOR MANUFACTURING, TENDERING OR FOR ANY OTHER PURPOSE WITHOUT THEIR WRITTEN PERMISSION.

**TOLERANCES**

X. = ±1mm  
X.X = ±0.50mm  
X.XX = ±0.10mm  
X.XXX = ±0.01mm  
ANGLES = ±5°  
UNLESS STATED

**MATERIAL:**

SEE ABOVE

**FINISH:**

SEE ABOVE

**S/AREA:**

mm<sup>2</sup>

**TITLE:** JACKSCREW DATAMATE DIL CRIMP (LARGE BORE) FEMALE ASSY WITH CABLE HOOD KIT

**DRAWING NUMBER:**

**M80-941XXXX**

SHT  
2 OF 2