

Plug-in Signal Conditioners K-UNIT

DC ALARM

(CE)

Functions & Features

- Providing relay contact closures at preset DC input levels
- Dual (Hi/Lo) trip
- Multi-turn screwdriver setpoint adjustments
- Monitor jacks provided for setpoint adjustments
- Enclosed relays
- Relays can be powered 110 V DC
- High-density mounting

Typical Applications

- Annunciator
- Various alarm applications

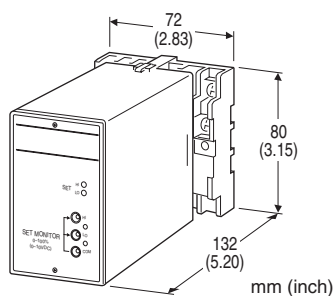

MODEL: KS2-[1]5-[2][3]

ORDERING INFORMATION

- Code number: KS2-[1]5-[2][3]
- Specify a code from below for each of [1] through [3].
(e.g. KS2-65-H/Q)
- Special input range (For codes Z & 0)
- Specify the specification for option code /Q
(e.g. /C01/S01)

[1] INPUT

Current

- A: 4 - 20 mA DC (Input resistance 250 Ω)
- A1: 4 - 20 mA DC (Input resistance 50 Ω)
- B: 2 - 10 mA DC (Input resistance 500 Ω)
- C: 1 - 5 mA DC (Input resistance 1000 Ω)
- D: 0 - 20 mA DC (Input resistance 50 Ω)
- E: 0 - 16 mA DC (Input resistance 62.5 Ω)
- F: 0 - 10 mA DC (Input resistance 100 Ω)
- G: 0 - 1 mA DC (Input resistance 1000 Ω)
- H: 10 - 50 mA DC (Input resistance 100 Ω)
- K: 0 - 100 μA DC (Input resistance 1000 Ω)
- GW: -1 - +1 mA DC (Input resistance 1000 Ω)

FW: -10 - +10 mA DC (Input resistance 100 Ω)

Z: Specify current (See INPUT SPECIFICATIONS)

Voltage

- 15: 0 - 50 mV DC (Input resistance 10 kΩ min.)
- 16: 0 - 60 mV DC (Input resistance 10 kΩ min.)
- 2: 0 - 100 mV DC (Input resistance 100 kΩ min.)
- 3: 0 - 1 V DC (Input resistance 1 MΩ min.)
- 4: 0 - 10 V DC (Input resistance 1 MΩ min.)
- 5: 0 - 5 V DC (Input resistance 1 MΩ min.)
- 6: 1 - 5 V DC (Input resistance 1 MΩ min.)
- 4W: -10 - +10 V DC (Input resistance 1 MΩ min.)
- 5W: -5 - +5 V DC (Input resistance 1 MΩ min.)
- 0: Specify voltage (See INPUT SPECIFICATIONS)

OUTPUT

5: Relay; SPDT or transfer contact

[2] POWER INPUT

AC Power

G: 200 V AC

H: 220 V AC

J: 240 V AC

DC Power

S: 12 V DC

R: 24 V DC

[3] OPTIONS

blank: none

/Q: With options (specify the specification)

SPECIFICATIONS OF OPTION: Q (multiple selections)

COATING (For the detail, refer to M-System's web site.)

/C01: Silicone coating

/C02: Polyurethane coating

/C03: Rubber coating

TERMINAL SCREW MATERIAL

/S01: Stainless steel

GENERAL SPECIFICATIONS

Construction: Plug-in

Connection: M3.5 screw terminals

Screw terminal: Chromated steel (standard) or stainless steel

Housing material: Flame-resistant resin (black)

Isolation: Input to output to power

Setpoint adjustments: Multi-turn screwdriver adjustments (front); 0 - 100% independently

Monitor jacks: Output 0 - 10 V for 0 - 100 % setpoints

Monitor jack diameter: 2 mm (.08")

Hysteresis (deadband): 0.5 - 1.0 %

Front LEDs: Red LEDs turn on when the coils are energized.
Power ON timer: Relays de-energized for approx. 2 seconds after power is turned on.

INPUT SPECIFICATIONS

■ DC Current:

Shunt resistor attached to the input terminals (0.5 W)
 Specify input resistance value for code Z.

■ DC Voltage: -30 - +30 V DC

Span: Min. 50 mV, Max. 30 V

Offset: Max. 1.5 times span

Input resistance

Span 50 - 100 mV : $\geq 10 \text{ k}\Omega$

Span 0.1 - 1 V : $\geq 100 \text{ k}\Omega$

Span $\geq 1 \text{ V}$: $\geq 1 \text{ M}\Omega$

OUTPUT SPECIFICATIONS

■ Relay Contact:

120 V AC @ 0.5 A ($\cos \theta = 1$)

240 V AC @ 0.5 A ($\cos \theta = 1$)

30 V DC @ 0.5 A (resistive load)

Maximum switching voltage: 380 V AC or 125 V DC

Maximum switching power: 120 VA or 30 W ($\leq 0.5 \text{ A}$)

Minimum load: 5 V DC @ 10 mA

Mechanical life: 5×10^7 cycles

For maximum relay life with inductive loads, external protection is recommended.

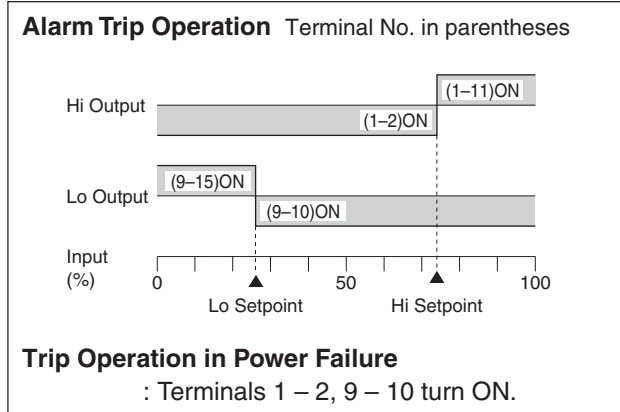

PERFORMANCE in percentage of span

Setpoint monitor accuracy: $\pm 0.5 \%$

Temp. coefficient: $\pm 0.02 \%/^{\circ}\text{C}$ ($\pm 0.01 \%/^{\circ}\text{F}$)

Response time: $\leq 0.5 \text{ sec.}$ (0 - 100 % at 90 % setpoint)

Line voltage effect: $\pm 0.1 \%$ over voltage range

Insulation resistance: $\geq 100 \text{ M}\Omega$ with 500 V DC

Dielectric strength: 2300 V AC @1 minute (input to output to power to ground)

STANDARDS & APPROVALS

EU conformity:

EMC Directive

EMI EN 61000-6-4

EMS EN 61000-6-2

Low Voltage Directive

EN 61010-1

Measurement Category II (output)

Installation Category II (power)

Pollution Degree 2

Input or output to power: Reinforced insulation (300 V)

Input to output: Basic insulation (300 V)

(When 150 V AC max. load voltage or measurement category I, applicable as reinforced insulation)

RoHS Directive

EN 50581

INSTALLATION

Power input

• **AC:** Operational voltage range: rating $\pm 10 \%$,
 50/60 $\pm 2 \text{ Hz}$, approx. 2 VA

• **DC:** Operational voltage range: rating $\pm 10 \%$,
 ripple 10 %p-p max., approx. 2 W (80 mA at 24 V)

Operating temperature: -5 to +55 $^{\circ}\text{C}$ (23 to 131 $^{\circ}\text{F}$)

Operating humidity: 30 to 90 %RH (non-condensing)

Mounting: Surface or DIN rail

Weight: 400 g (0.88 lb)

EXTERNAL VIEW

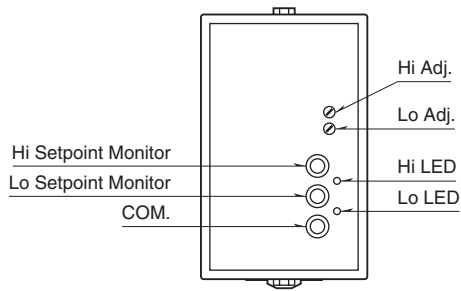

EXTERNAL DIMENSIONS unit: mm (inch)

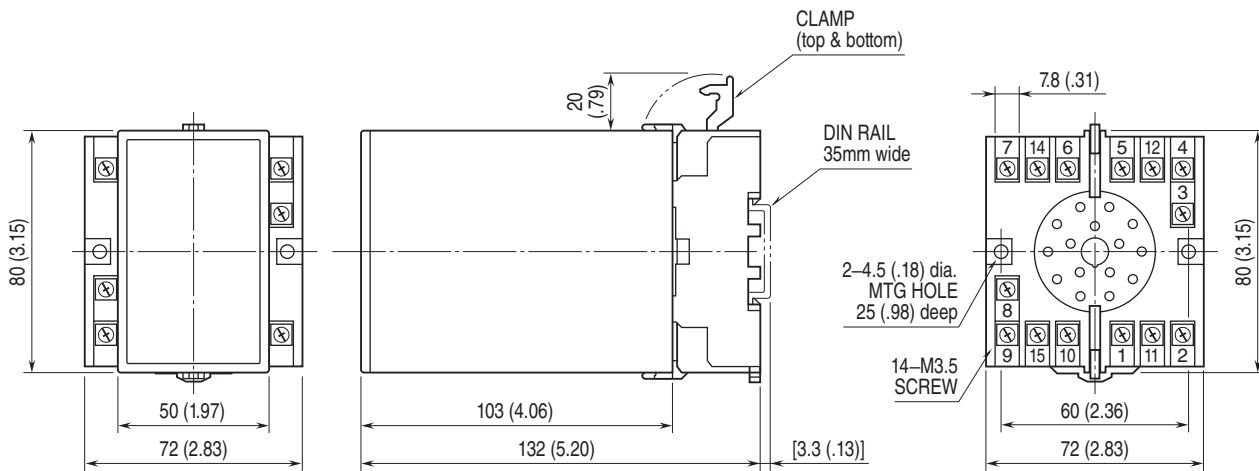

• When mounting, no extra space is needed between units.

TERMINAL ASSIGNMENTS unit: mm (inch)

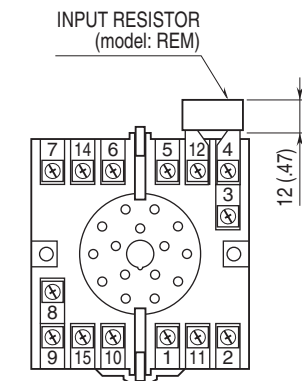

Input shunt resistor attached for current input.

SCHEMATIC CIRCUITRY & CONNECTION DIAGRAM

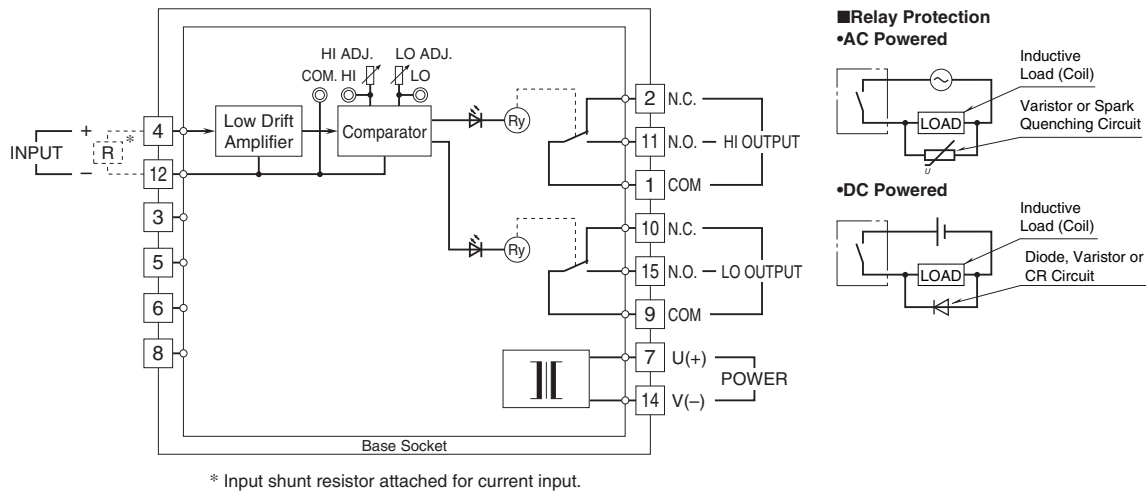

Specifications are subject to change without notice.