

iC-DN

LOWSIDE SWITCH



Rev C1, Page 1/10

FEATURES

- ◆ 36 V lowside switch/level shifter
- ◆ Decoupling of input and output reference voltages permits control by 5 V logic
- ◆ 200 mA of output current
- ◆ Short-circuit protected
- ◆ Output with an active freewheeling circuit
- ◆ On-chip over-temperature protection with hysteresis
- ◆ 4 to 36 V input voltage range
- ◆ Input with hysteresis
- ◆ Wide temperature range of -40 to 120 °C

APPLICATIONS

- ◆ Lowside switch for industrial applications, such as relays, inductive proximity sensors and light barriers

PACKAGES

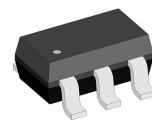

SOT23-6L

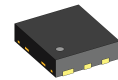

UDFN6-1.8x2

BLOCK DIAGRAM

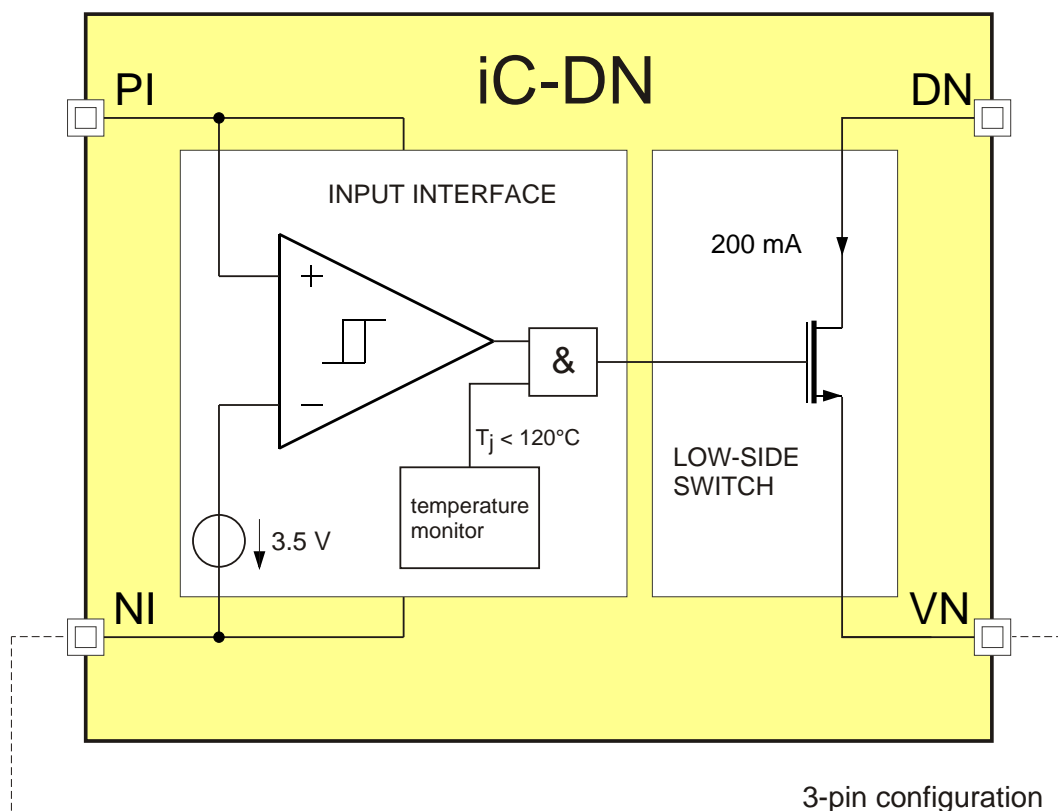

iC-DN

LOWSIDE SWITCH



Rev C1, Page 2/10

DESCRIPTION

iC-DN is a monolithic lowside switch for ohmic, inductive and capacitive loads.

Designed for a wide input voltage range of 4 to 36 V, it is capable of supplying a minimum output current of 200 mA. The output acts as a current source with a low saturation voltage; protection against short-circuiting is provided by the device shutting down with

excessive temperature. The chip is activated when the input voltage threshold $V(PI)-V(NI)$ of typically 3.5 V is exceeded.

With four leads, the input (PI, NI) and output (DN, VN) reference voltages are decoupled. The maximum permissible voltage difference between NI and VN is 36 V.

PACKAGING INFORMATION

PIN CONFIGURATION

SOT23-6L (JEDEC), 1.6 mm

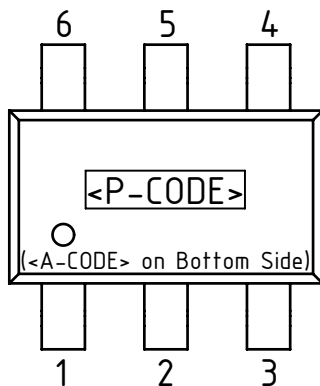

PIN FUNCTIONS

No. Name Function

1	n.c.	
2	VN	Ground, Substrate
3	NI	Input Reference Voltage
4	n.c.	
5	PI	Positive Input, Supply
6	DN	Output

PIN CONFIGURATION

UDFN6-1.8x2

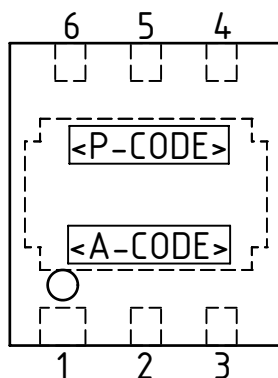

PIN FUNCTIONS

No. Name Function

1	NI	Input Reference Voltage
2	VN	Ground, Substrate
3	n.c.	
4	DN	Output
5	n.c.	
6	PI	Positive Input, Supply

PACKAGE DIMENSIONS

SIDE

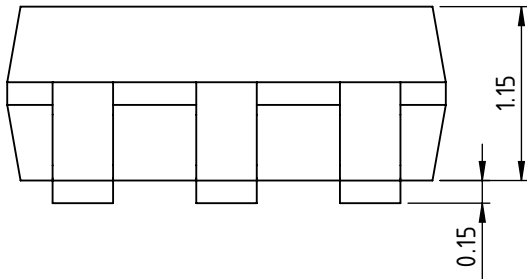

FRONT

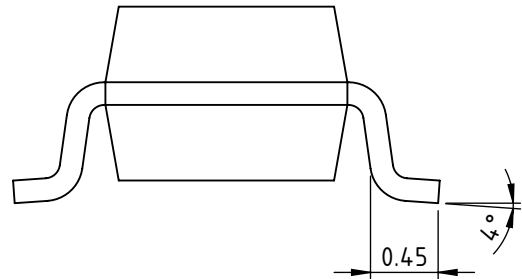

TOP

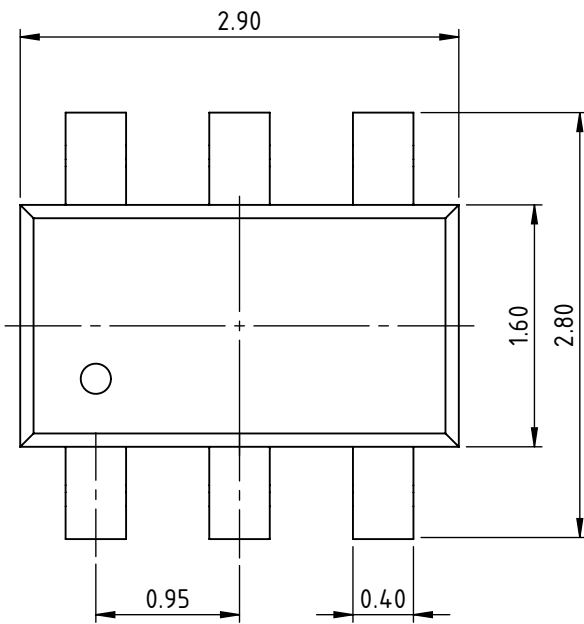

RECOMMENDED PCB-FOOTPRINT

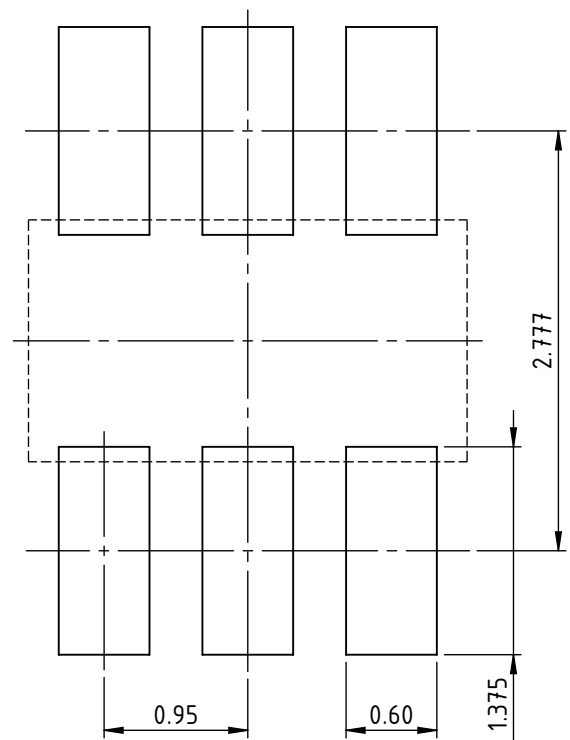

All dimensions given in mm. Tolerances of form and position according to JEDEC MO-178.

PACKAGE DIMENSIONS

RECOMMENDED PCB-FOOTPRINT

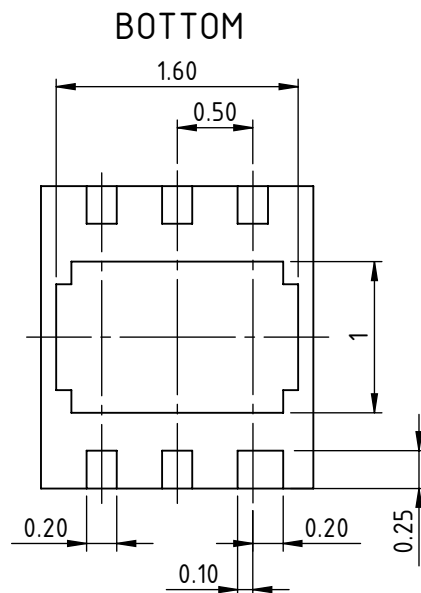
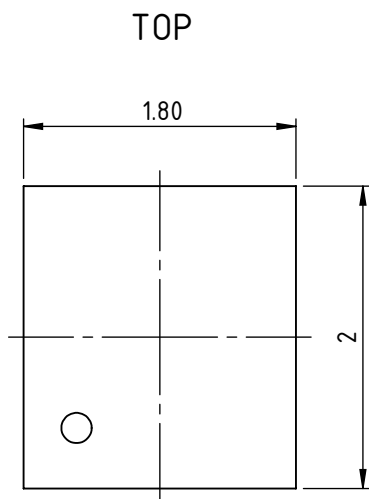
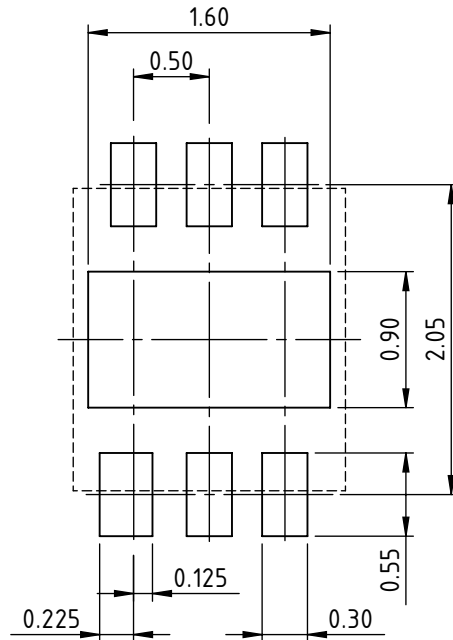
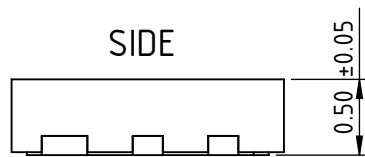

All dimensions given in mm.
Tolerances of form and position according to JEDEC MO-229.

ABSOLUTE MAXIMUM RATINGS

Beyond these values damage may occur; device operation is not guaranteed. Absolute Maximum Ratings are no Operating Conditions. Integrated circuits with system interfaces, e.g. via cable accessible pins (I/O pins, line drivers) are per principle endangered by injected interferences, which may compromise the function or durability. The robustness of the devices has to be verified by the user during system development with regard to applying standards and ensured where necessary by additional protective circuitry. By the manufacturer suggested protective circuitry is for information only and given without responsibility and has to be verified within the actual system with respect to actual interferences.

Item No.	Symbol	Parameter	Conditions	Min. Max.		Unit
				Min.	Max.	
G001	V()	PI, NI Input Voltage with reference to VN	$V() = V(PI) - V(VN)$ or $V() = V(NI) - V(VN)$	-0.3	40	V
G002	V(DN)	DN Output Voltage	No free wheeling	-0.3	40	V
G003	I(DN)	DN Output Current			300	mA
G004	I(PI)	PI Input Current			10	mA
G005	I(NI)	NI Input Current		-10		mA
G006	Vd()	ESD Susceptibility	HBM 100 pF discharged through 1.5 kΩ		2	kV
G007	Tj	Max. Junction Temperature		-40	150	°C
G008	Ts	Storage Temperature Range		-40	150	°C
G009	Eas	Inductive load switch-off energy dissipation	Temperature monitor not active, $T_j < T_{on}$		5	mJ

THERMAL DATA

Operating Conditions: $V(PI) = 4...36V$, unless otherwise stated

Item No.	Symbol	Parameter	Conditions	Min. Typ. Max.			Unit
				Min.	Typ.	Max.	
T01	Ta	Ambient Temperature Range		-40		120	°C

All voltages are referenced to ground (VN) unless otherwise stated.

All currents flowing into the device pins are positive; all currents flowing out of the device pins are negative.

iC-DN

LOWSIDE SWITCH



Rev C1, Page 6/10

ELECTRICAL CHARACTERISTICS

Operating Conditions: $V(PI) = 4...36\text{ V}$, $T_j = -40...120\text{ °C}$, unless otherwise stated

Item No.	Symbol	Parameter	Conditions	Min.	Typ.	Max.	Unit
Total Device							
001	V(PI)	PI Supply Voltage with reference to VN		4		36	V
002	I(PI)	PI Supply Current	No load; $(V(PI) - V(NI)) > V(PI)_{on}$ (301) $(V(PI) - V(NI)) < V(PI)_{off}$ (302)	250 0		950 750	μA μA
003	I(NI)	NI Input Current	No load; $(V(PI) - V(NI)) > V(PI)_{on}$ $(V(PI) - V(NI)) < V(PI)_{off}$	-500 -200		20 0	μA μA
004	I(VN)	VN Supply Current	No load; $(V(PI) - V(NI)) > V(PI)_{on}$ $(V(PI) - V(NI)) < V(PI)_{off}$	-650 -600		-200 0	μA μA
005	I _{lk} (DN)	DN Output Leakage Current	$(V(PI) - V(NI)) < V(PI)_{off}$, $V(DN) = 0...36\text{ V}$	-100		100	μA
006	V _c (DN) _{hi}	DN Clamp Voltage high	$V_c(DN)_{hi} = V(DN) - V(VN)$, $I(DN) = 10\text{ mA}$	40	45	60	V
007	V _c (DN) _{lo}	DN Clamp Voltage low	$V_c(DN)_{lo} = V(DN) - V(VN)$, $I(DN) = -10\text{ mA}$	-1		-0.3	V
008	V _c (_{)_{hi}}	PI, NI Clamp Voltage high	$V_c()_{hi} = V() - V(VN)$, $I() = 4\text{ mA}$	37	40		V
009	V _c (_{)_{lo}}	PI, NI Clamp Voltage low	$V_c()_{lo} = V() - V(VN)$, $I() = -4\text{ mA}$	-1		-0.3	V
010	tp _{iohi}	Activation Delay PI → DN	$V(PI)_{on} < (V(PI) - V(NI)) < 36\text{ V}$, $V(Rload) = 36\text{ V}$, $Rload = 360\ \Omega$, $I(DN) = 0 \rightarrow 90\text{ mA}$	0.6		6	μs
011	tp _{iol}	Deactivation Delay PI → DN	$(V(PI) - V(NI)) < V(PI)_{off}$, $V(Rload) = 36\text{ V}$, $Rload = 360\ \Omega$, $I(DN) = 100 \rightarrow 10\text{ mA}$	0.6		35	μs
Lowside Output DN							
101	V _s (DN)	Output Saturation Voltage	DN = I _o ; $I(DN) = 200\text{ mA}$ $I(DN) = 50\text{ mA}$			600 150	mV mV
102	I _{sc} (DN)	Output Short-Circuit Current	$V(DN) = 1\text{ V}...V_B$, DN = I _o	200	300	550	mA
103	SR(DN) _{on}	Slew Rate V(DN) → 0	$(V(PI) - V(NI)) > V(PI)_{on}$, $V(Rload) = 36\text{ V}$, $Rload = 360\ \Omega$, $V(DN) = 32.4 \rightarrow 3.6\text{ V}$		65		V/ μs
104	SR(DN) _{off}	Slew Rate V(DN) → V(PI)	$(V(PI) - V(NI)) < V(PI)_{off}$, $V(Rload) = 36\text{ V}$, $Rload = 360\ \Omega$, $V(DN) = 3.6 \rightarrow 32.4\text{ V}$		20		V/ μs
105	V _{fw} (DN)	Freewheeling Voltage	$I(DN) = 200\text{ mA}$	40	45	60	V
Temperature Monitor							
201	T _{off}	Thermal Shutdown Threshold		120		150	°C
202	T _{on}	Thermal Release Threshold	Decreasing temperature	110		135	°C
203	Th _{ys}	Thermal Shutdown Hysteresis	$Th_{ys} = T_{off} - T_{on}$		15		°C
Input Threshold							
301	V(PI) _{on}	Power-On Threshold Voltage	$V(PI) - V(NI)$	2.7		4.3	V
302	V(PI) _{off}	Power-Off Threshold Voltage	$V(PI) - V(NI)$, decreasing voltage	1.7		3.9	V
303	V(PI) _{hys}	Hysteresis	$V(PI)_{hys} = V(PI)_{on} - V(PI)_{off}$	160	250	1200	mV

ELECTRICAL CHARACTERISTIC: DIAGRAMS

Simulation Data

(current consumption without load; leakage currents not included)

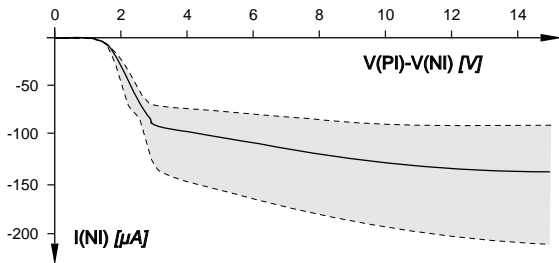

Figure 1: NI input current, load independent

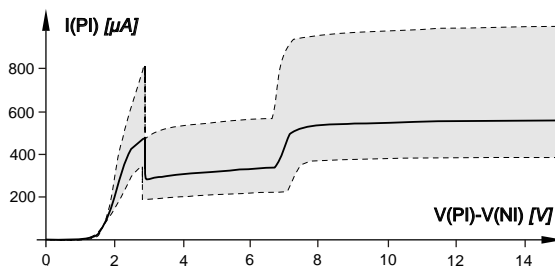

Figure 2: PI input current, no load

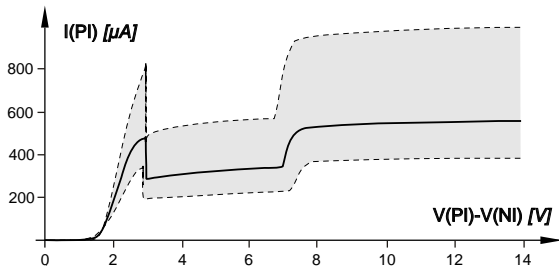

Figure 3: PI input current, $I(\text{DN}) = 5 \text{ mA}$

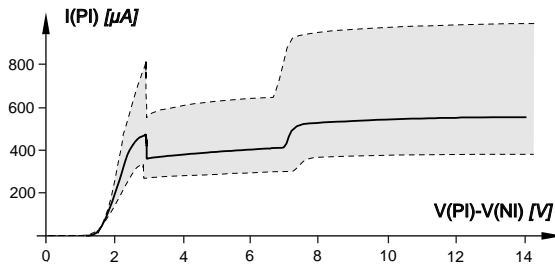

Figure 4: PI input current, $I(\text{DN}) = 100 \text{ mA}$

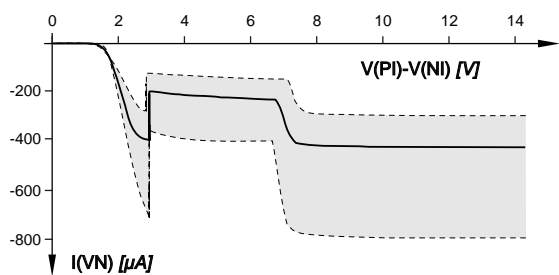

Figure 5: VN supply current

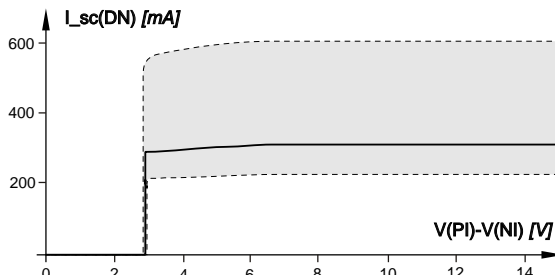

Figure 6: DN short-circuit output current

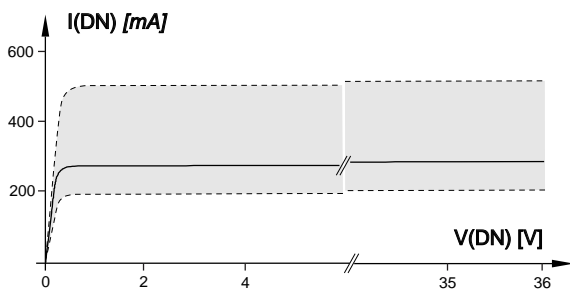

Figure 7: DN output characteristic

APPLICATION NOTES

Example application circuits

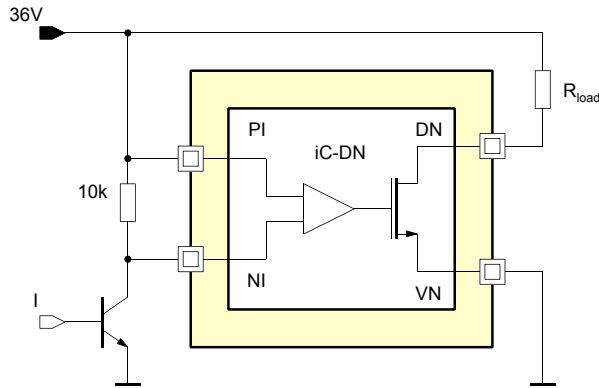

Figure 8: 36 V supply, NPN input control

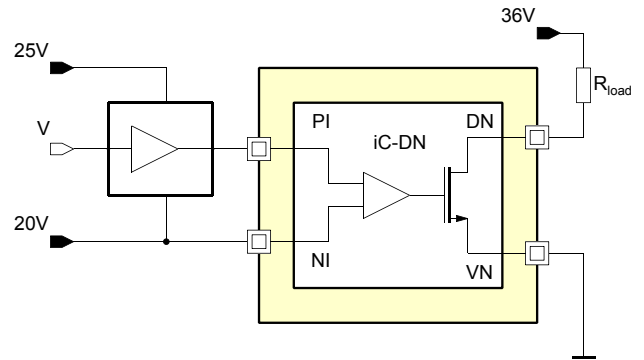

Figure 9: 5 V μ C operation at 20 to 25 V input control, 36 V output supply

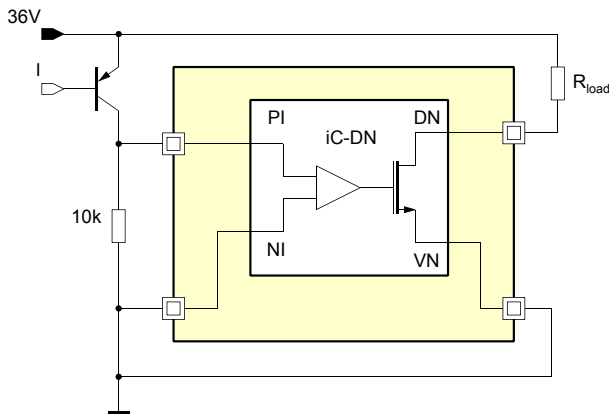

Figure 10: 36 V supply, PNP input control

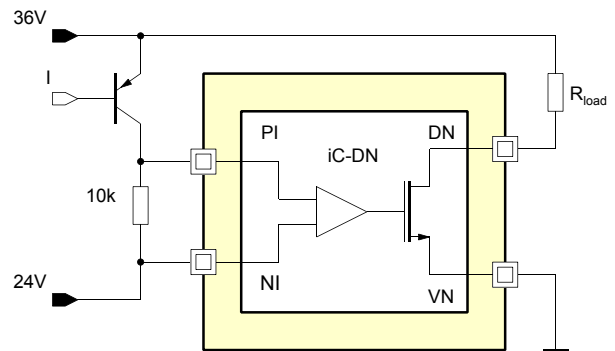

Figure 11: 12 V PNP input control, 36 V supply

REVISION HISTORY

Rel.	Rel. Date*	Chapter	Modification	Page
B1	2007-04-03		previous version	

Rel.	Rel. Date*	Chapter	Modification	Page
C1	2016-04-07	PACKAGES	new package type UDFN6 introduced	2,3,4
	2016-04-07	ORDERING INFORMATION	ordering information added for UDFN6 package	10
	2016-04-07	APPLICATION NOTES	figures modified	8

iC-Haus expressly reserves the right to change its products and/or specifications. An info letter gives details as to any amendments and additions made to the relevant current specifications on our internet website www.ichaus.com/infoletter; this letter is generated automatically and shall be sent to registered users by email.

Copying – even as an excerpt – is only permitted with iC-Haus' approval in writing and precise reference to source.

iC-Haus does not warrant the accuracy, completeness or timeliness of the specification and does not assume liability for any errors or omissions in these materials.

The data specified is intended solely for the purpose of product description. No representations or warranties, either express or implied, of merchantability, fitness for a particular purpose or of any other nature are made hereunder with respect to information/specification or the products to which information refers and no guarantee with respect to compliance to the intended use is given. In particular, this also applies to the stated possible applications or areas of applications of the product.

iC-Haus products are not designed for and must not be used in connection with any applications where the failure of such products would reasonably be expected to result in significant personal injury or death (*Safety-Critical Applications*) without iC-Haus' specific written consent. Safety-Critical Applications include, without limitation, life support devices and systems. iC-Haus products are not designed nor intended for use in military or aerospace applications or environments or in automotive applications unless specifically designated for such use by iC-Haus.

iC-Haus conveys no patent, copyright, mask work right or other trade mark right to this product. iC-Haus assumes no liability for any patent and/or other trade mark rights of a third party resulting from processing or handling of the product and/or any other use of the product.

* Release Date format: YYYY-MM-DD

ORDERING INFORMATION

Type	Package	Order Designation
iC-DN	SOT23-6L UDFN6-1.8x2	iC-DN SOT23-6L iC-DN UDFN6-1.8x2

Please send your purchase orders to our order handling team:

Fax: +49 (0) 61 35 - 92 92 - 692

E-Mail: dispo@ichaus.com

For technical support, information about prices and terms of delivery please contact:

iC-Haus GmbH
Am Kuemmerling 18
D-55294 Bodenheim
GERMANY

Tel.: +49 (0) 61 35 - 92 92 - 0
Fax: +49 (0) 61 35 - 92 92 - 192
Web: <http://www.ichaus.com>
E-Mail: sales@ichaus.com

Appointed local distributors: http://www.ichaus.com/sales_partners